

MODEL K2500E500-HT

500 LBF SHAKER SYSTEM WITH SLIP TABLE

- Uses 2500E shaker providing 500 lbf (2.2 kN) sine and 350 lbf (1.6 kN) random force
- Flexible design allows shaker to be detached from the table and used in a traditional vertical vibration testing setup
- 12 in x 12 in (305 mm x 305 mm) oil film slip table supports larger, heavier payloads
- 1.0 in (25.4 mm) stroke and wide frequency range supports broad range of applications
- Shaker is equipped with degauss coil for low stray field for testing sensitive electronics
- Uses the compact 2050E12-7 digital power amplifier

APPLICATIONS

- General vibration stress screening of electronics and mechanical sub-assemblies
- Qualification testing per ISO, SAE, MIL-STD, and other vibration test standards
- Telecommunication, satellite, and computer equipment testing
- Avionics, automotive, and military hardware environmental testing

EXPANDED VIBRATION TESTING

The K2500E500-HT builds on the capability of the largest 2500E shaker from The Modal Shop with the addition of a slip table to expand useability in a variety of R&D, reliability, and quality assurance applications. The large, 12 in (305 mm) square oil film slip table mounting surface provides high load and off-center moment capability for applications where heavy (typically up to 60 lb / 27 kg) or dimensionally large loads are to be tested. The slip table surface is configured with 1/4-20 (or M6) threaded mounting holes on a 2.5 in (63.5 mm) square grid for payload/fixture attachment.

The test system also allows the 2500E shaker to be uncoupled from the slip table and rotated up 90 degrees for testing of items in the vertical direction. Components can be mounted directly on the shaker armature, via additional 12 in (305 mm) square head expander, or using a Modal-Pod™ CubeSat fixture. The shaker's internal high lateral stiffness carbon composite armature suspension reduces problems associated with off-center loads when operating vertically.

The system features The Modal Shop's compact 2050E12-7 high efficiency digital switch mode amplifier to deliver full system performance in a compact rack mountable form factor while simplifying power and amplifier cooling requirements. Safety features of the amplifier include over travel switch protection, air-cooling flow interlocks, and safe start in mute mode. The K2500E500-HT system includes the shaker, horizontal table, 2050E12-7 digital switching amplifier, and shaker cooling package. The end of the slip table has a 10-32 mounting hole to attach a general purpose accelerometer for feedback loop vibration control.

SPECIFICATIONS

Performance	
Output Force, sine pk, forced air cooling	500 lbf (2.2 kN) ^[1]
Output Force, random RMS, forced air cooling	350 lbf (1.6 kN) ^[1]
Output Force, shock pk	1000 lbf (4.4 kN) ^[1]
Stroke Length, continuous pk-pk	1.0 in (25.4 mm)
Frequency Range (with slip table), nominal	2 – 3000 Hz ^[2]
Fundamental Resonance (with slip table)	> 2700 Hz ^[2]
Frequency Range (without slip table), nominal	2 – 4500 Hz ^[2]
Fundamental Resonance (without slip table)	> 3300 Hz ^[2]
Maximum Velocity (with slip table)	70 in/s pk (1.78 m/s pk) ^[2]
Maximum Acceleration (with slip table)	26 g pk (255 m/s ² pk) ^[2]
Physical	
Slip Table Mass	14 lb (6.4 kg)
Shaker Armature Mass	5 lb (2.3 kg)
Total Moving Mass	19 lb (8.6 kg)
Slip Table Mounting Surface	12 in x 12 in (305 mm x 305 mm)
Overall Dimensions (H x W x D)	23.5 in x 19.5 in x 37.3 in (597 mm x 495 mm x 947 mm)
Table Mounting Hole Thread	1/4-20 ^[3]
Table Mounting Hole Pattern	2.5 in (63.5 mm) square grid
Total Weight (base + shaker)	1000 lb (453.6 kg)
Oil Reservoir Capacity	0.4 Gal (1.5 L) ^[4]
System Components	
2500E Shaker	Installed in mounting base
2050E12-7 Power Amplifier	3500 VA, field power supply, 200-240V, single phase. 115 lb, 8.8 in x 19 in x 17 in (52 kg, 224 mm x 482 mm x 432 mm)
2000X12 Cooling Vacuum	Cooling Package
Interconnect Cables, Hoses, and Accessories	10 ft (3 m) shaker cable, 12 ft, (3.66 m) cooling duct, wrenches, standard isolation mount
Optional Accessories	
2000X14 Magnesium Head Expander	12 x 12 in (305 x 305 mm)
2000X15 Modal-Pod™	CubeSat Test Fixture
2000X16	Pneumatic Vibration Isolation Mount, 5 Hz
J352C34	Ground Isolated Accelerometer (100 mV/g)

[1] Full force range requires forced air cooling with 2050E12-7 power amplifier.

[2] Load dependent, stated specifications based upon bare table.

[3] 1/4 -20 standard, M6 x 1 option available.

[4] Mineral Oil.

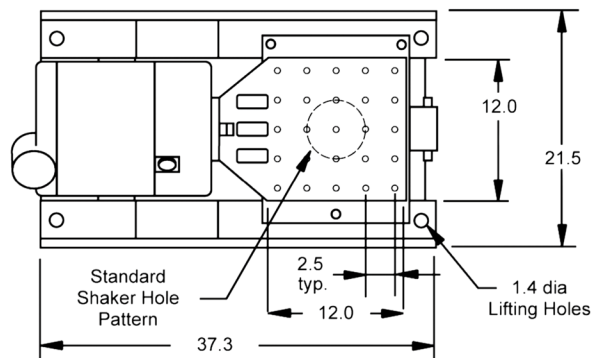
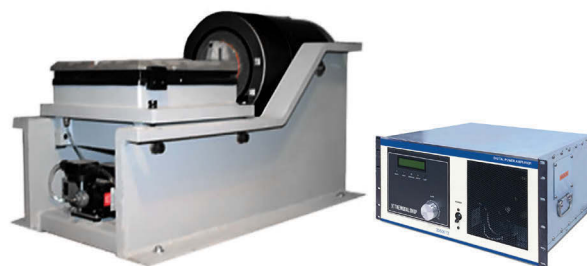

Model K2500E500-HT - Top View

Dimensions in inches

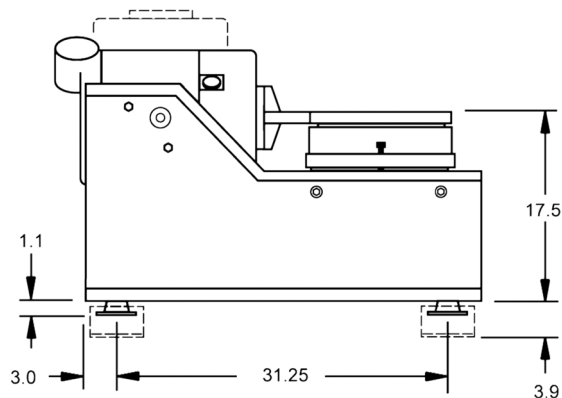

Model K2500E500-HT - Side View

Dimensions in inches