



**Model 740M04**  
**Uniaxial ICP® Strain Sensor**  
**Installation and Operating Manual**

**For assistance with the operation of this product,  
contact PCB Piezotronics, Inc.**

**Toll-free: 800-828-8840**  
**24-hour SensorLine: 716-684-0001**  
**Fax: 716-684-0987**  
**E-mail: [info@pcb.com](mailto:info@pcb.com)**  
**Web: [www.pcb.com](http://www.pcb.com)**





<b>Warranty, Service, Repair, and Return Policies and Instructions</b>
--

**The information contained in this document supersedes all similar information that may be found elsewhere in this manual.**

**Total Customer Satisfaction** – PCB Piezotronics guarantees Total Customer Satisfaction. If, at any time, for any reason, you are not completely satisfied with any PCB product, PCB will repair, replace, or exchange it at no charge. You may also choose to have your purchase price refunded in lieu of the repair, replacement, or exchange of the product.

**Service** – Due to the sophisticated nature of the sensors and associated instrumentation provided by PCB Piezotronics, user servicing or repair is not recommended and, if attempted, may void the factory warranty. Routine maintenance, such as the cleaning of electrical connectors, housings, and mounting surfaces with solutions and techniques that will not harm the physical material of construction, is acceptable. Caution should be observed to insure that liquids are not permitted to migrate into devices that are not hermetically sealed. Such devices should only be wiped with a dampened cloth and never submerged or have liquids poured upon them.

**Repair** – In the event that equipment becomes damaged or ceases to operate, arrangements should be made to return the equipment to PCB Piezotronics for repair. User servicing or repair is not recommended and, if attempted, may void the factory warranty.

**Calibration** – Routine calibration of sensors and associated instrumentation is recommended as this helps build confidence in measurement accuracy and acquired data. Equipment calibration cycles are typically established by the users own quality regimen. When in doubt about a calibration cycle, a good “rule of thumb” is to recalibrate on an annual basis. It is also good practice to recalibrate after exposure to any severe temperature extreme, shock, load, or other environmental influence, or prior to any critical test.

PCB Piezotronics maintains an ISO-9001 certified metrology laboratory and offers calibration services, which are accredited by A2LA to ISO/IEC 17025, with full traceability to SI through N.I.S.T. In addition to the normally supplied calibration, special testing is also available, such as: sensitivity at elevated or cryogenic temperatures, phase response, extended high or low frequency response, extended range, leak testing, hydrostatic pressure testing, and others. For information on standard recalibration services or special testing, contact your local PCB Piezotronics distributor, sales representative, or factory customer service representative.

**Returning Equipment** – *Following these procedures will insure that your returned materials are handled in the most expedient manner.* Before

returning any equipment to PCB Piezotronics, contact your local distributor, sales representative, or factory customer service representative to obtain a Return **Warranty, Service, Repair, and Return Policies and Instructions** Materials Authorization (RMA) Number. This RMA number should be clearly marked on the outside of all package(s) and on the packing list(s) accompanying the shipment. A detailed account of the nature of the problem(s) being experienced with the equipment should also be included inside the package(s) containing any returned materials.

A Purchase Order, included with the returned materials, will expedite the turn-around of serviced equipment. It is recommended to include authorization on the Purchase Order for PCB to proceed with any repairs, as long as they do not exceed 50% of the replacement cost of the returned item(s). PCB will provide a price quotation or replacement recommendation for any item whose repair costs would exceed 50% of replacement cost, or any item that is not economically feasible to repair. For routine calibration services, the Purchase Order should include authorization to proceed and return at current pricing, which can be obtained from a factory customer service representative.

**Warranty** – All equipment and repair services provided by PCB Piezotronics, Inc. are covered by a limited warranty against defective material and workmanship for a period of one year from date of original purchase. Contact

PCB for a complete statement of our warranty. Expendable items, such as batteries and mounting hardware, are not covered by warranty. Mechanical damage to equipment due to improper use is not covered by warranty. Electronic circuitry failure caused by the introduction of unregulated or improper excitation power or electrostatic discharge is not covered by warranty.

**Contact Information** – International customers should direct all inquiries to their local distributor or sales office. A complete list of distributors and offices can be found at [www.pcb.com](http://www.pcb.com). Customers within the United States may contact their local sales representative or a factory customer service representative. A complete list of sales representatives can be found at [www.pcb.com](http://www.pcb.com). Toll-free telephone numbers for a factory customer service representative, in the division responsible for this product, can be found on the title page at the front of this manual. Our ship to address and general contact numbers are:

PCB Piezotronics, Inc.  
3425 Walden Ave.  
Depew, NY14043 USA  
Toll-free: (800) 828-8840  
24-hour SensorLine<sup>SM</sup>: (716) 684-0001  
Website: [www.pcb.com](http://www.pcb.com)  
E-mail: [info@pcb.com](mailto:info@pcb.com)



PCB工业监视和测量设备 - 中国RoHS2公布表  
 PCB Industrial Monitoring and Measuring Equipment - China RoHS 2 Disclosure Table

部件名称	有害物质					
	铅 (Pb)	汞 (Hg)	镉 (Cd)	六价铬 (Cr(VI))	多溴联苯 (PBB)	多溴二苯醚 (PBDE)
住房	○	○	○	○	○	○
PCB板	X	○	○	○	○	○
电气连接器	○	○	○	○	○	○
压电晶体	X	○	○	○	○	○
环氧	○	○	○	○	○	○
铁氟龙	○	○	○	○	○	○
电子	○	○	○	○	○	○
厚膜基板	○	○	X	○	○	○
电线	○	○	○	○	○	○
电缆	X	○	○	○	○	○
塑料	○	○	○	○	○	○
焊接	X	○	○	○	○	○
铜合金/黄铜	X	○	○	○	○	○
本表格依据 SJ/T 11364 的规定编制。						
○：表示该有害物质在该部件所有均质材料中的含量均在 GB/T 26572 规定的限量要求以下。						
X：表示该有害物质至少在该部件的某一均质材料中的含量超出 GB/T 26572 规定的限量要求。						
铅是欧洲RoHS指令2011/65/ EU附件三和附件四目前由于允许的豁免。						

CHINA RoHS COMPLIANCE

Component Name	Hazardous Substances					
	Lead (Pb)	Mercury (Hg)	Cadmium (Cd)	Chromium VI Compounds (Cr(VI))	Polybrominated Biphenyls (PBB)	Polybrominated Diphenyl Ethers (PBDE)
Housing	O	O	O	O	O	O
PCB Board	X	O	O	O	O	O
Electrical Connectors	O	O	O	O	O	O
Piezoelectric Crystals	X	O	O	O	O	O
Epoxy	O	O	O	O	O	O
Teflon	O	O	O	O	O	O
Electronics	O	O	O	O	O	O
Thick Film Substrate	O	O	X	O	O	O
Wires	O	O	O	O	O	O
Cables	X	O	O	O	O	O
Plastic	O	O	O	O	O	O
Solder	X	O	O	O	O	O
Copper Alloy/Brass	X	O	O	O	O	O

This table is prepared in accordance with the provisions of SJ/T 11364.

O: Indicates that said hazardous substance contained in all of the homogeneous materials for this part is below the limit requirement of GB/T 26572.

X: Indicates that said hazardous substance contained in at least one of the homogeneous materials for this part is above the limit requirement of GB/T 26572.

Lead is present due to allowed exemption in Annex III or Annex IV of the European RoHS Directive 2011/65/EU.

DOCUMENT NUMBER: 21354

DOCUMENT REVISION: C

ECN: 45605

# General OPERATING GUIDE

for use with

## MODEL 740B02 PIEZOELECTRIC ICP<sup>®</sup> STRAIN SENSOR

SPECIFICATION SHEET, INSTALLATION DRAWING  
AND CALIBRATION INFORMATION ENCLOSED

PCB ASSUMES NO RESPONSIBILITY FOR DAMAGE CAUSED TO THIS PRODUCT AS A RESULT OF PROCEDURES THAT ARE INCONSISTENT WITH THIS OPERATING GUIDE.

### 1.0 INTRODUCTION AND DESCRIPTION

Congratulations on the purchase of a quality PCB sensor. In order to ensure the highest level of performance for this product, it is imperative that you properly familiarize yourself with the correct mounting and installation techniques before attempting to operate this device. If, after reading this manual, you have any additional questions concerning this sensor or its application, feel free to call a Factory Application Engineer at 716-684-0001.

The Model 740B02 Strain Sensor is structured with a quartz sensing element and microelectronic circuitry in a low-profile titanium housing, making it the ideal choice for high-resolution measurements of dynamic strain. The unit is capable of measuring small strain on top of large static loads. The sensor is compatible with PCB's ICP<sup>®</sup> Sensor signal conditioners and is capable of driving long cables. Typical applications include: active vibration control, noise-path analysis, modal testing, use on aircraft and marine hulls, composite materials, "smart" structures, and vibrating machinery. See Figure 1.

### 2.0 ICP<sup>®</sup> STRAIN SENSOR BACKGROUND

ICP<sup>®</sup> is a registered trademark that uniquely describes PCB's piezoelectric sensors with built-in microelectronics. Powered by simple, low-cost, constant-current signal conditioners, these sensors are easily incorporated into high-precision, low-impedance systems having the following characteristics:

- Fixed voltage sensitivity, regardless of cable type or length.
- Low-impedance output; can be transmitted over long cables in harsh environments with virtually no loss in signal quality.
- Two-wire system: uses standard coaxial or two-wire cabling.
- High-resolution, voltage output, compatible with standard readout, recording, and other data acquisition equipment.
- Low per-channel cost; this strain sensor requires only low-cost, constant-current signal conditioners.
- Intrinsic self-test feature; checks sensor bias voltage.

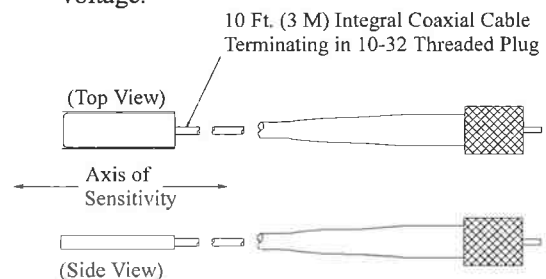

Figure 1. Model 740B02 Strain Sensor

Enclosed is a **Specification Sheet**, which lists the complete performance characteristics of the sensor.

### 3.0 INSTALLATION

The suggested method of mounting the Model 740B02 Strain Sensor is direct adhesive mounting with a quick-bonding gel. *Proper mounting is critical to good sensor performance.* All surfaces must be clean, dry, and free

of oils before applying adhesive. The sensor should be mounted directly on the test structure according to the following procedure:

**STEP 1:** Prepare a smooth, flat mounting surface. A minimum surface finish of 63  $\mu\text{in}$  (0.00016 mm) generally works best.

**STEP 2:** Place a small portion of adhesive on the underside of the sensor. The adhesive layer must be thin and uniform. Firmly press down on the assembly to displace any extra adhesive. Be aware that excessive amounts of adhesive may affect the response of the unit.

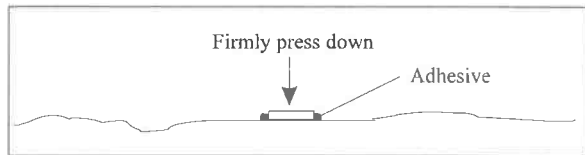

**Figure 2.** Typical Adhesive Mounting

#### 4.0 REMOVAL (other than wax)

**NOTE:** A debonder should always be used to avoid sensor damage.

To avoid damaging the strain sensor, a debonding agent must be applied to the adhesive prior to sensor removal. With so many adhesives in use (everything from super glues, dental cement, epoxies, etc), there is no universal debonding agent available. The debonder for the Loctite 454 adhesive that PCB offers is Acetone. If you are using anything other than Loctite 454, you will have to check with the individual manufacturers for their debonding recommendations. The debonding agent must be allowed to penetrate the surface in order to properly react with the adhesive, so it is advisable to wait a few minutes before removing the sensor.

After the debonding agent has set, use the supplied removal tool and use a gentle shearing (or twisting) motion (by hand only) to remove the sensor from the test structure.

#### 5.0 POWERING

All ICP<sup>®</sup> sensors require constant current excitation for proper operation. For this reason, use only PCB constant current signal conditioners or other approved constant current sources. A typical system schematic is shown hereafter.

**Note:** Damage to the built-in electronics resulting from the application of incorrect power or the use of an unapproved power source is NOT covered by warranty.

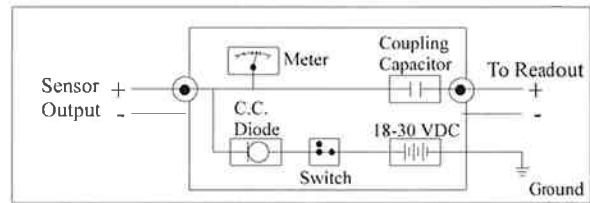

**Figure 3.** Typical System Schematic

The power supply consists of a well-regulated 18 to 30 VDC source. In general, battery-powered devices offer versatility for portable, low-noise measurements; line-powered units provide the capability for continuous monitoring. This voltage is regulated by a current-limiting circuit that provides the constant current excitation for proper operation of ICP<sup>®</sup> sensors.

**Note:** Under no circumstances should a voltage be supplied to an ICP<sup>®</sup> sensor without a current-regulating diode or equivalent electrical circuit.

Meters or LEDs are used to monitor the bias voltage on the sensor output signal to check sensor operation and detect cable faults. Normally, a “yellow” reading indicates an open circuit; “green” indicates normal operation; and “red” indicates either a short or overload condition. Finally, a capacitor at the output stage of the device removes the sensor output bias voltage from the measurement signal. This provides a zero-based, AC-coupled output compatible with most standard readout devices.

**Note:** “Buffered” or “DC-coupled” signal conditioners should be used on readout devices with an input impedance less than one megohm.

Today, many FFT analyzers, data acquisition modules, and data collectors incorporate constant current excitation for direct use with ICP<sup>®</sup> sensors. However, before using this feature, check that the supply voltage and constant current are adequate for use with your sensor.

Please contact the respective Signal Conditioner Manufacturer or check the product manual for additional information.

## 6.0 OPERATING

After completing the system setup, switch on the signal conditioner and allow 1 or 2 minutes for the system to stabilize. After this time, the meter (or LED) on the signal conditioner should be reading "green." This indicates proper operation and you are ready to begin taking measurements. If a faulty condition is monitored, first check all system connections and then check the functionality of the cable and signal conditioner. If this system still does not operate properly, feel free to consult a PCB Applications Engineer.

**Note:** Always operate the sensor within the limitations listed on the enclosed *Specification Sheet*. Operating the device outside these parameters can cause temporary or perhaps even permanent damage to the sensor.

## 7.0 FREQUENCY RESPONSE

The upper limit to the frequency response is determined either by cable drive considerations or by wavelength of dynamic strain.

Long cables capacitively load the sensor output. Long cables and measurement of high frequency may require the use of a higher current (>2 mA) power supply. For more information on long cable driving, see the appropriate section in the Vibration Division's Sensor Catalog. For short cable lengths (<10 ft [3 m]), a 2 mA constant-current supply is usually sufficient for a frequency range up to 100 kHz.

Measurements are accurate when the wavelength is large compared to the length of the sensor. Wavelength can be determined from the following formula:

$$\lambda = c / f$$

Where  $c$  is the speed of sound and  $f$  is the frequency.

A good rule of thumb is that the wavelength should be ten times the length of the sensor. The upper frequency limit can be determined from the following equation:

$$f_u = 0.1c / L$$

$L$  is the length of the sensor. The table below provides the speed of sound for various materials, the wavelength at 100,000 Hz, and the upper frequency limit for a one cm-long piezoelectric strain sensor.

Material	c (m/s)	Wavelength @ 100 kHz (cm)	Freq. limit for 1 cm - long strain sensor
Titanium	5068 m/s	5.1 cm	51 kHz
Aluminum	5040 m/s	5.0 cm	50 kHz
Steel	5140 m/s	5.1 cm	51 kHz
Plexiglass	2600 m/s	2.6 cm	26 kHz
Beryllium	12870 m/s	129 cm	129 kHz

## 8.0 SENSITIVITY

The strain sensor sensitivity is calibrated by the method shown in the figure below. The sensor under calibration is attached to the base of a steel cantilever beam and sensor output is compared to a precision resistive strain gage reference sensor.

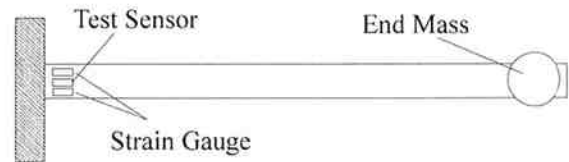

**Figure 4.** Calibration of Strain Sensor

The steel cantilever, with end mass, measures 26 x 2 x 0.25 inches (66.04 x 5.08 x 0.635 centimeters). The frequency is 5.7 Hz. When the stiffness modulus of the structure under test is less than the modulus of steel, the actual sensitivity is less than the calibrated sensitivity. The following table compares the Model 740B02 sensitivity when attached to a steel, aluminum, or acrylic beam.

Cantilever Beam Material	Young's Modulus (psi)	Sensitivity (mV/ $\mu\epsilon$ )
Steel	$30 \times 10^6$	50
Aluminum	$10 \times 10^6$	41
Acrylic	$0.4 \times 10^6$	5

## 9.0 REPAIR/SERVICE

Because of the delicate nature of most PCB instrumentation, field repair is typically NOT recommended and may void any warranty. Before returning equipment for repair, it is strongly suggested that the user confer with a factory application engineer (or local sales contact) concerning the difficulty, to ascertain if an on-site procedure may rectify the problem. If factory service is required, return the instrument according to the **RETURN PROCEDURE**



below. A quotation is provided prior to servicing at no additional charge.

## 10.0 RETURN PROCEDURE

To expedite the repair process, contact a PCB Customer Service Representative for a **RETURN MATERIAL AUTHORIZATION (RMA)** number prior to sending equipment to the factory. Please have information available such as model and serial number. Also, to insure efficient service, be sure to include a written description of the symptoms and problems with the equipment to your local sales contact, or contact PCB if none are located in your area. Customers outside the U.S. should consult their local PCB sales contact for information on returning equipment. For exceptions, please contact the International Sales department at PCB to request shipping instructions and an RMA. For assistance, please call (716) 684-0001, or fax us at (716) 684-0987. You may also receive assistance via e-mail at [sales@pcb.com](mailto:sales@pcb.com) or visit our web site at [www.pcb.com](http://www.pcb.com).

## 11.0 CUSTOMER SERVICE/WARRANTY

The employees of PCB strive to provide superior, unmatched customer service. Should you at any time find yourself dissatisfied with any PCB product for any reason, consult a PCB application engineer to discuss repair, refund, or exchange procedures.

PCB instrumentation is warranted against defective material and workmanship for one year unless otherwise expressly specified. Damage to instruments caused by

incorrect power or misapplication is not covered by warranty. If there is any question regarding power, intended application or general usage, please consult with your local sales contact or distributor. Batteries and other expendable hardware items are not covered by warranty.

When unexpected measurement problems arise, call our 24-hour SensorLine<sup>SM</sup> to discuss your immediate measurement instrumentation needs with a Factory Representative. Dial 716-684-0001.

**MANUAL NUMBER: 18294**  
**MANUAL REVISION: A**



3425 Walden Avenue, Depew, NY 14043-2495 USA **Vibration Division toll-free 888-684-0013**  
**24-hour SensorLine<sup>SM</sup> 716-684-0001 FAX 716-685-3886 E-mail vibration@pcb.com Website www.pcb.com**

ISO 9001 CERTIFIED

© 2001 PCB Group, Inc. In the interest of constant product improvement, specifications are subject to change without notice. PCB, and ICP are registered trademarks of PCB Group, Inc. All other trademarks are properties of their respective owners.

Model Number  
740M04

# UNIAXIAL ICP® STRAIN SENSOR

Revision: F  
ECN #: 22938

	ENGLISH	SI	
<b>Performance</b>			
Sensitivity (± 20 %)	5 mV/μϵ	5 mV/μϵ	[4]
Measurement Range	900 pk μϵ	900 pk μϵ	
Frequency Range	0.5 to 100,000 Hz	0.5 to 100,000 Hz	[5]
Bandwidth Resolution (1 to 10,000 Hz)	5.0 nϵ	5.0 nϵ	[1]
Non-Linearity	≤ 1.5 %	≤ 1.5 %	[6]
Transverse Sensitivity	≤ 5 %	≤ 5 %	[1]
<b>Environmental</b>			
Overload Limit (Shock)	± 10,000 g pk	± 98,000 m/s <sup>2</sup> pk	
Temperature Range	-65 to +250 °F	-53 to +121 °C	
Acceleration Sensitivity	0.001 μϵ/g	0.0001 μϵ/(m/s <sup>2</sup> )	[3][1]
<b>Electrical</b>			
Excitation Voltage	20 to 30 VDC	20 to 30 VDC	
Constant Current Excitation	2 to 20 mA	2 to 20 mA	
Output Bias Voltage	8 to 14 VDC	8 to 14 VDC	
Discharge Time Constant	1 to 3 sec	1 to 3 sec	
Spectral Noise (1 Hz)	1900 pϵ/√Hz	1900 pϵ/√Hz	[1][2]
Spectral Noise (10 Hz)	600 pϵ/√Hz	600 pϵ/√Hz	[1]
Spectral Noise (100 Hz)	200 pϵ/√Hz	200 pϵ/√Hz	[1]
Spectral Noise (1 kHz)	60 pϵ/√Hz	60 pϵ/√Hz	[1]
Spectral Noise (10 kHz)	15 pϵ/√Hz	15 pϵ/√Hz	[1]
<b>Physical</b>			
Sensing Element	Quartz	Quartz	
Housing Material	Titanium	Titanium	
Sealing	Epoxy	Epoxy	
Size (Width x Length x Height)	0.2 in x 0.6 in x 0.07 in	5.1 mm x 15.2 mm x 1.8 mm	
Weight	0.02 oz	0.5 gm	[1]
Electrical Connector	10-32 Coaxial Jack	10-32 Coaxial Jack	
Mounting	Adhesive	Adhesive	
Cable Length	10 ft	10 ft	
Cable Type	030 Coaxial	030 Coaxial	

**OPTIONAL VERSIONS**  
Optional versions have identical specifications and accessories as listed for the standard model except where noted below. More than one option may be used.

**NOTES:**

- [1] Typical.
- [2] Strain level equivalent.
- [3] Measured perpendicular to sensing axis.
- [4] Calibrated on steel bar.
- [5] Based on cable drive of 100 ft at 30 pF/ft 20 mA excitation.
- [6] Zero-based, least-squares, straight line method.
- [7] See PCB Declaration of Conformance PS023 for details.

**SUPPLIED ACCESSORIES:**

- Model 039A07 Removal Tool (1)
- Model 080A90 Quick Bonding Gel (1)

Entered: <i>LH</i>	Engineer: <i>MEY</i>	Sales: <i>wx</i>	Approved: <i>MJ</i>	Spec Number:
Date: <i>10/5/05</i>	Date: <i>10-5-05</i>	Date: <i>10/5/05</i>	Date: <i>10/5/05</i>	4204



[7]

All specifications are at room temperature unless otherwise specified.  
In the interest of constant product improvement, we reserve the right to change specifications without notice.  
ICP® is a registered trademark of PCB Group, Inc.

**PCB PIEZOTRONICS™**  
VIBRATION DIVISION  
3425 Walden Avenue, Depew, NY 14043

Phone: 716-684-0001  
Fax: 716-685-3886  
E-Mail: vibration@pcb.com

PCB Piezotronics Inc. claims proprietary rights in the information disclosed hereon. Neither it nor any reproduction thereof will be disclosed to others without written consent of PCB Piezotronics Inc.

REVISIONS

REV	DESCRIPTION	ECN	APP'D
B	UPDATED TO SHOW ETCHING	14985	DM 3/02
C	REMOVE MODEL NO. FROM CABLE	28295	MDF 3/08

9600

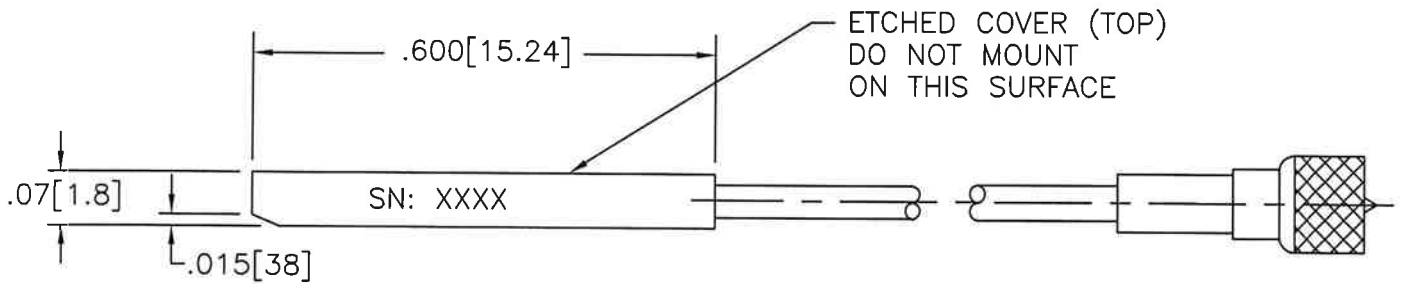
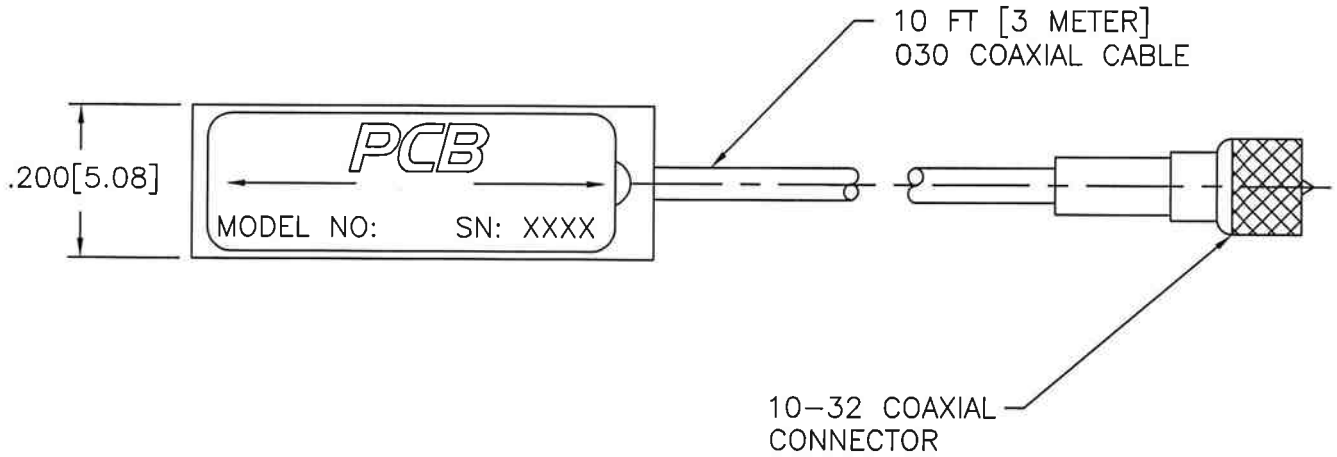

UNLESS SPECIFIED TOLERANCES		DRAWN	MDF	3/3/08	MFG	DC	3/3/08	 3425 WALDEN AVE. DEPEW, NY 14043 (716) 684-0001 EMAIL: SALES@PCB.COM
DIMENSIONS IN INCHES	DIMENSIONS IN MILLIMETERS [IN BRACKETS]	CHK'D	MDF	3/3/08	ENGR	BM	3/3/08	
DECIMALS XX ±.03 XXX ±.010	DECIMALS X ±0.8 XX ±0.25	APP'D	EB	3/3/08	SALES	RL	3/3/08	
ANGLES ±2 DEGREES	ANGLES ±2 DEGREES	TITLE OUTLINE DRAWING MODEL 740 SERIES LOW PROFILE STRAIN GAUGE						CODE IDENT. NO. 52681
FILLETS AND RADII .003 - .005	FILLETS AND RADII [0.07 - 0.13]							DWG. NO. 9600
DD011 REV. D 01/17/08								SCALE: 4X
							SHEET 1 OF 1	