



Model EX682A40
DIFFERENTIAL DIN RAIL CHARGE AMPLIFIER
Installation and Operating Manual

**For assistance with the operation of this product,
contact PCB Piezotronics, Inc.**

Toll-free: 800-828-8840
24-hour SensorLine: 716-684-0001
Fax: 716-684-0987
E-mail: info@pcb.com
Web: www.pcb.com



Repair and Maintenance

PCB guarantees Total Customer Satisfaction through its “Lifetime Warranty Plus” on all Platinum Stock Products sold by PCB and through its limited warranties on all other PCB Stock, Standard and Special products. Due to the sophisticated nature of our sensors and associated instrumentation, **field servicing and repair is not recommended and, if attempted, will void the factory warranty.**

Beyond routine calibration and battery replacements where applicable, our products require no user maintenance. Clean electrical connectors, housings, and mounting surfaces with solutions and techniques that will not harm the material of construction. Observe caution when using liquids near devices that are not hermetically sealed. Such devices should only be wiped with a dampened cloth—never saturated or submerged.

In the event that equipment becomes damaged or ceases to operate, our Application Engineers are here to support your troubleshooting efforts 24 hours a day, 7 days a week. Call or email with model and serial number as well as a brief description of the problem.

Calibration

Routine calibration of sensors and associated instrumentation is necessary to maintain measurement accuracy. We recommend calibrating on an annual basis, after exposure to any extreme environmental influence, or prior to any critical test.

PCB Piezotronics is an ISO-9001 certified company whose calibration services are accredited by A2LA to ISO/IEC 17025, with full traceability to SI through N.I.S.T. In addition to our standard calibration services, we also offer specialized tests, including: sensitivity at elevated or cryogenic temperatures, phase response, extended high or low frequency response, extended range, leak testing, hydrostatic pressure testing, and others. For more information, contact your local PCB Piezotronics distributor, sales representative, or factory customer service representative.

Returning Equipment

If factory repair is required, our representatives will provide you with a Return Material Authorization (RMA) number, which we use to reference any information you have already provided and expedite the repair process. This number should be clearly marked on the outside of all returned package(s) and on any packing list(s) accompanying the shipment.

Contact Information

PCB Piezotronics, Inc.
3425 Walden Ave.
Depew, NY14043 USA
Toll-free: (800) 828-8840
24-hour SensorLine: (716) 684-0001
General inquiries: info@pcb.com
Repair inquiries: rma@pcb.com

For a complete list of distributors, global offices and sales representatives, visit our website, www.pcb.com.

Safety Considerations

This product is intended for use by qualified personnel who recognize shock hazards and are familiar with the precautions required to avoid injury. While our equipment is designed with user safety in mind, the protection provided by the equipment may be impaired if equipment is used in a manner not specified by this manual.

Discontinue use and contact our 24-Hour Sensorline if:

- Assistance is needed to safely operate equipment
- Damage is visible or suspected
- Equipment fails or malfunctions

For complete equipment ratings, refer to the enclosed specification sheet for your product.

Definition of Terms and Symbols

The following symbols may be used in this manual:



DANGER

Indicates an immediate hazardous situation, which, if not avoided, may result in death or serious injury.

**CAUTION**

Refers to hazards that could damage the instrument.

**NOTE**

Indicates tips, recommendations and important information. The notes simplify processes and contain additional information on particular operating steps.

The following symbols may be found on the equipment described in this manual:



This symbol on the unit indicates that high voltage may be present. Use standard safety precautions to avoid personal contact with this voltage.



This symbol on the unit indicates that the user should refer to the operating instructions located in the manual.



This symbol indicates safety, earth ground.



PCB工业监视和测量设备 - 中国RoHS2公布表

PCB Industrial Monitoring and Measuring Equipment - China RoHS 2 Disclosure Table

部件名称	有害物质					
	铅 (Pb)	汞 (Hg)	镉 (Cd)	六价铬 (Cr(VI))	多溴联苯 (PBB)	多溴二苯醚 (PBDE)
住房	0	0	0	0	0	0
PCB板	X	0	0	0	0	0
电气连接器	0	0	0	0	0	0
压电晶体	X	0	0	0	0	0
环氧	0	0	0	0	0	0
铁氟龙	0	0	0	0	0	0
电子	0	0	0	0	0	0
厚膜基板	0	0	X	0	0	0
电线	0	0	0	0	0	0
电缆	X	0	0	0	0	0
塑料	0	0	0	0	0	0
焊接	X	0	0	0	0	0
铜合金/黄铜	X	0	0	0	0	0
本表格依据 SJ/T 11364 的规定编制。						
0：表示该有害物质在该部件所有均质材料中的含量均在 GB/T 26572 规定的限量要求以下。						
X：表示该有害物质至少在该部件的某一均质材料中的含量超出 GB/T 26572 规定的限量要求。						
铅是欧洲RoHS指令2011/65/ EU附件三和附件四目前由于允许的豁免。						

CHINA RoHS COMPLIANCE

Component Name	Hazardous Substances					
	Lead (Pb)	Mercury (Hg)	Cadmium (Cd)	Chromium VI Compounds (Cr(VI))	Polybrominated Biphenyls (PBB)	Polybrominated Diphenyl Ethers (PBDE)
Housing	O	O	O	O	O	O
PCB Board	X	O	O	O	O	O
Electrical Connectors	O	O	O	O	O	O
Piezoelectric Crystals	X	O	O	O	O	O
Epoxy	O	O	O	O	O	O
Teflon	O	O	O	O	O	O
Electronics	O	O	O	O	O	O
Thick Film Substrate	O	O	X	O	O	O
Wires	O	O	O	O	O	O
Cables	X	O	O	O	O	O
Plastic	O	O	O	O	O	O
Solder	X	O	O	O	O	O
Copper Alloy/Brass	X	O	O	O	O	O

This table is prepared in accordance with the provisions of SJ/T 11364.

O: Indicates that said hazardous substance contained in all of the homogeneous materials for this part is below the limit requirement of GB/T 26572.

X: Indicates that said hazardous substance contained in at least one of the homogeneous materials for this part is above the limit requirement of GB/T 26572.

Lead is present due to allowed exemption in Annex III or Annex IV of the European RoHS Directive 2011/65/EU.

Model EX682 Series Differential Charge Amplifier



Operating Guide with Enclosed Warranty Information

3425 Walden Avenue, Depew, New York 14043-2495

Phone (716) 684-0003

Fax (716) 684-3823

Toll Free Line 1-800-959-4IMI

MANUAL NUMBER: 55855
MANUAL REVISION: **D**
ECN NUMBER: **47061**

Table of Contents

Introduction..... Page 3
 General Features

Installation and Wiring Page 3-5

ESD Sensitivity..... Page 6

Warranty/Service

Warranty, Service & Return Procedure Page 7

Customer Service..... Page 8

Introduction

The EX682 Series of differential charge input amplifiers are designed to interface with differential output charge sensors. The unit will convert the charge signal from any differential output charge sensor into a voltage output. The front end differential charge amplifiers are designed to handle low sensor resistance that is common at very elevated temperatures (>500°F). An ICP® Din Rail Signal Conditioner is required for use with the differential charge amplifier, to provide the appropriate power supply.

General Features

- Din Rail Mount
- Removable Terminal Blocks for easy wiring
- 35mm (1.38in.) Din Rail Mount configuration
- Space saving 22.5mm (0.9in.) wide design

Installation and Wiring

Installation

The EX682 Series is designed to be mounted on a 35mm Din Rail. Do not install in a harsh area where it can be exposed to cleaning fluids or machine oils. The unit should be mounted in a NEMA type enclosure to protect the electronics from contamination.

CE Requirements

The EX682 Series is CE marked (see Declaration of Conformity for specific standards). To meet the requirement, the unit must be installed in a grounded metallic enclosure and sensor cable shield terminated to enclosure. Failure to do so can cause erroneous readings where high frequency noise is present.

Outline Drawing

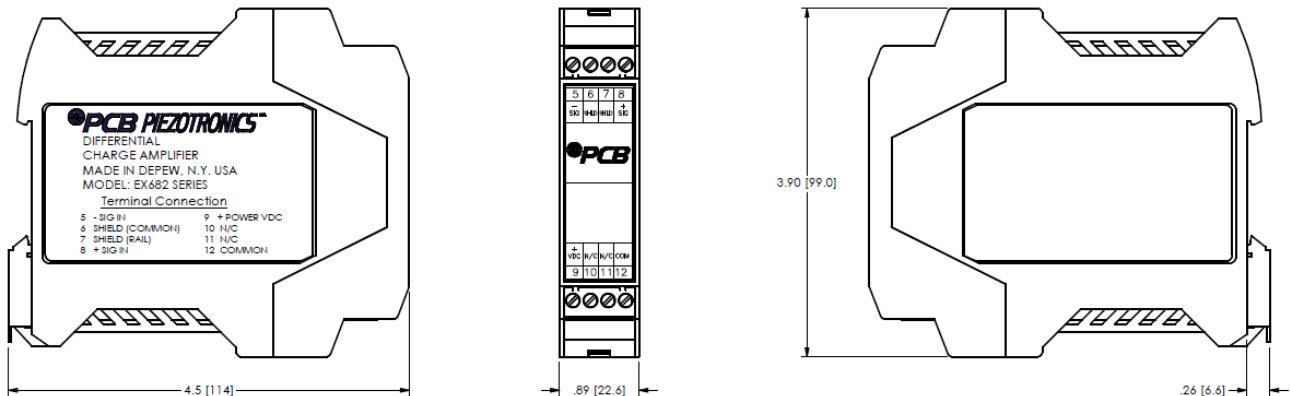

Connector and Pinout Diagram

The EX682 Series use plug-in type screw terminal connectors for all input and output connections.

Strip off ~8mm of insulation from the connection wire ends. Using a small screwdriver, remove the terminal block from the enclosure in either the up or down direction, terminate the wire in the correct location. Do not exceed a torque of 0.5Nm. Do not leave excess uninsulated wire which can short to adjacent wiring. Re-install the terminal block.

This easy to assemble connection method allows devices to be exchanged easily and the electrical connection to be visibly isolated.



Pin Descriptions:

- Pin 5: Sig -**
Negative Charge Input Signal
- Pin 6: Shield (Common)**
This pin connects shield to Pin 12.
- Pin 7: Shield (Rail)**
This pin connects to the Din Rail bar that the amplifier is mounted on.
- Pin 8: Sig +**
Positive Charge Input Signal
- Pin 9: VDC +**
Attach to the positive of ICP[®] power supply
- Pin 10: N/C**
No Connection
- Pin 11: N/C**
No Connection
- Pin 12: Common**
Attach to the negative of ICP[®] power supply

NOTE: An ICP[®] signal conditioner such as PCB Model 682A02 should be used to provide a constant current ICP[®] power supply to Pins 9 and 12.

Typical Wiring Diagram

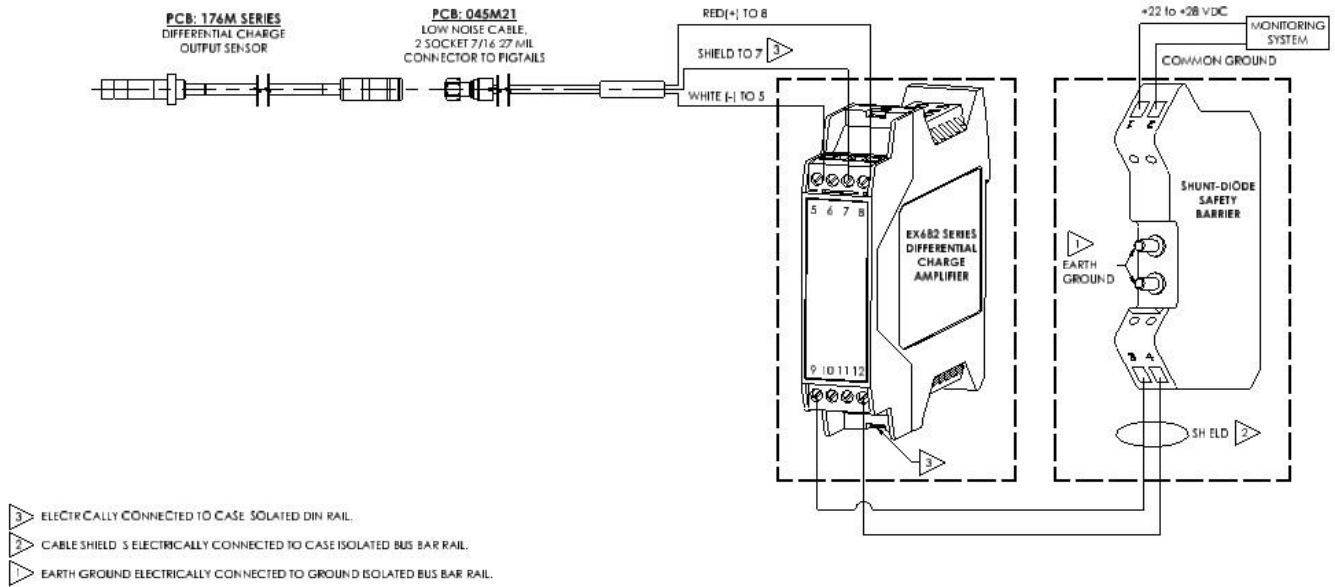

Warning 1 – ESD sensitivity

The power supply/signal conditioner should not be opened by anyone other than qualified service personnel. This product is intended for use by qualified personnel who recognize shock hazards and are familiar with the safety precautions required to avoid injury.

Warning 2 – ESD sensitivity

This equipment is designed with user safety in mind; however, the protection provided by the equipment may be impaired if the equipment is used in a manner not specified by PCB Piezotronics, Inc.

Caution 1 – ESD sensitivity

Cables can kill your equipment. High voltage electrostatic discharge (ESD) can damage electrical devices. Similar to a capacitor, a cable can hold a charge caused by triboelectric transfer, such as that which occurs in the following:

- *Laying on and moving across a rug,*
- *Any movement through air,*
- *The action of rolling out a cable, and/or*
- *Contact with a non-grounded person.*

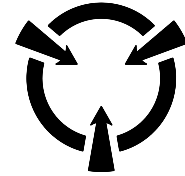

CAUTION
ELECTROSTATIC
DISCHARGE SENSITIVE

The PCB solution for product safety:

- *Connect the cables only with the AC power off.*
- *Temporarily “short” the end of the cable before attaching it to any signal input or output.*

Caution 2 – ESD sensitivity

ESD considerations should be made prior to performing any internal adjustments on the equipment. Any piece of electronic equipment is vulnerable to ESD when opened for adjustments. Internal adjustments should therefore be done ONLY at an ESD-safe work area. Many products have ESD protection, but the level of protection may be exceeded by extremely high voltage.

Warranty

IMI instrumentation is warranted against defective material and workmanship for 1 year unless otherwise expressly specified. Damage to instruments caused by incorrect power or misapplication, is not covered by warranty. *If there are any questions regarding power, intended application, or general usage, please consult with your local sales contact or distributor.* Batteries and other expendable hardware items are not covered by warranty.

Service

Because of the sophisticated nature of IMI instrumentation, field repair is typically **NOT** recommended and may void any warranty. If factory service is required, return the instrumentation according to the "Return Procedure" stated below. *A repair and/or replacement quotation will be provided prior to servicing at no charge.* Before returning the unit, please consult a factory IMI applications engineer concerning the situation as certain problems can often be corrected with simple on-site procedures.

Return procedure

To expedite returned instrumentation, contact a factory IMI applications engineer for a RETURN MATERIAL AUTHORIZATION (RMA) NUMBER. Please have information available such as model and serial number. Also, to insure efficient service, *provide a written description of the symptoms and problems with the equipment to a local sales representative or distributor, or contact IMI if none are located in your area.*

Customers outside the U.S. should consult their local IMI distributor for information on returning equipment. For exceptions, please contact the International Sales department at IMI to request shipping instructions and an RMA. For assistance, please call (716) 684-0003, or fax us at (716) 684-3823. You may also receive assistance via e-mail at imi@pcb.com or visit our web site at www.pcb.com.



Customer Service

IMI, a division of PCB Piezotronics, guarantees **Total Customer Satisfaction**. If, at any time, for any reason, you are not completely satisfied with any IMI product, IMI will repair, replace, or exchange it at no charge. You may also choose, within the warranty period, to have your purchase price refunded.

IMI offers to all customers, at no charge, 24-hour phone support. This service makes product or application support available to our customers, day or night, seven days a week. When unforeseen problems or emergency situations arise, call the **IMI Hot Line at (716) 684-0003**, and an application specialist will assist you.



3425 Walden Avenue, Depew, NY 14043-2495
Phone: (716) 684-0003 • USA Fax: (716) 684-3823 • INTL Fax: (716) 684-4703

*ICP® is a registered trademark of PCB Group, Incorporated,
which uniquely identifies PCB sensors that incorporate built-in microelectronics.*

62544

PCB Piezotronics Inc. claims proprietary rights in the information disclosed hereon. Neither it nor any reproduction thereof will be disclosed to others without the written consent of PCB Piezotronics Inc.

RELATED DRAWING

NO MODIFICATIONS PERMITTED WITHOUT THE APPROVAL OF THE AUTHORIZED PERSON

REVISIONS		
REV	DESCRIPTION	DIN
A	UPDATED DELTA NOTE 1 (mH WAS uH)	50514

5.) MODEL NUMBER EX682XXXX CERTIFICATE:
 LCIE 13 ATEX 1010 X
 LCIE 13 ATEX 3031 X
 IECEx LCIE 13.0002X

4 SHIELDS TO BE EARTHED AT BARRIER END

3 THE INSTALLER SHALL INSURE THAT THE SENSOR MOUNTING STRUCTURE IS AT THE SAME GROUNDING POTENTIAL AS THE BARRIER GROUND TOTAL EARTH LOOP IMPEDANCE SHALL BE LESS THAN ONE OHM

2 BARRIER WILL BE MOUNTED IN AN ENCLOSURE THE SUITABILITY OF WHICH WILL BE DETERMINED BY LOCAL AUTHORITIES

1 ENTITY APPLICATION:

BARRIER		I.S. APPARATUS
Voc/Uo	≤	V _{MAX} /Ui
Ics/Io	≤	I _{MAX} /Ii
Ca/Co	>	Ci+C _{CABLE}
La/Lo	>	Li+L _{CABLE}
Po	≤	Pi

BARRIERS WITHIN THE SPECIFIED LIMITATIONS ARE PERMITTED

ENTITY PARAMETERS:

Ui = 28V	Uo = 28V
Ii = 100mA	Io = 60mA
Pi = 0.7W	Po = 0.42W
Ci = 0 nF	Co = 83 nF
Li = 0 uH	Lo = 10 mH

CERTIFIED BY THE APPROPRIATE APPROVAL AUTHORITY FOR CONNECTION TO THE FOLLOWING AREAS:
 ZONE 0
 EX ia IIC T4 Ga

UNLESS OTHERWISE SPECIFIED

NON HAZARDOUS/ SAFE AREA

HAZARDOUS AREA
 ZONE 0

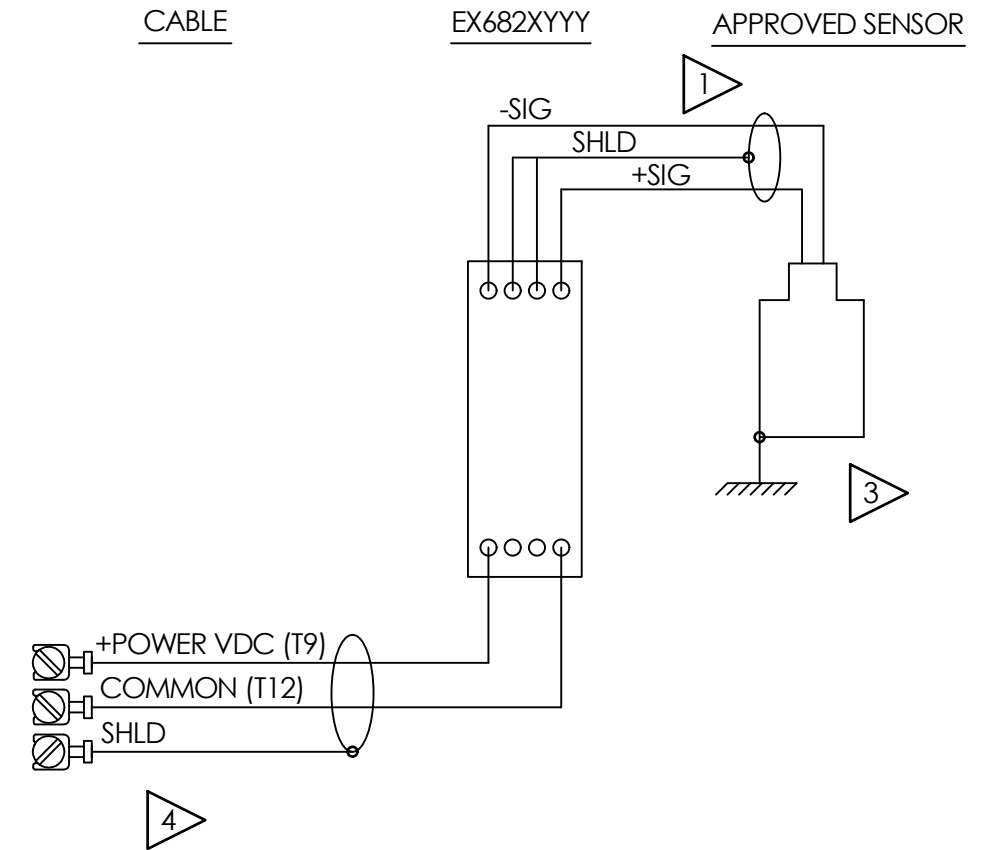
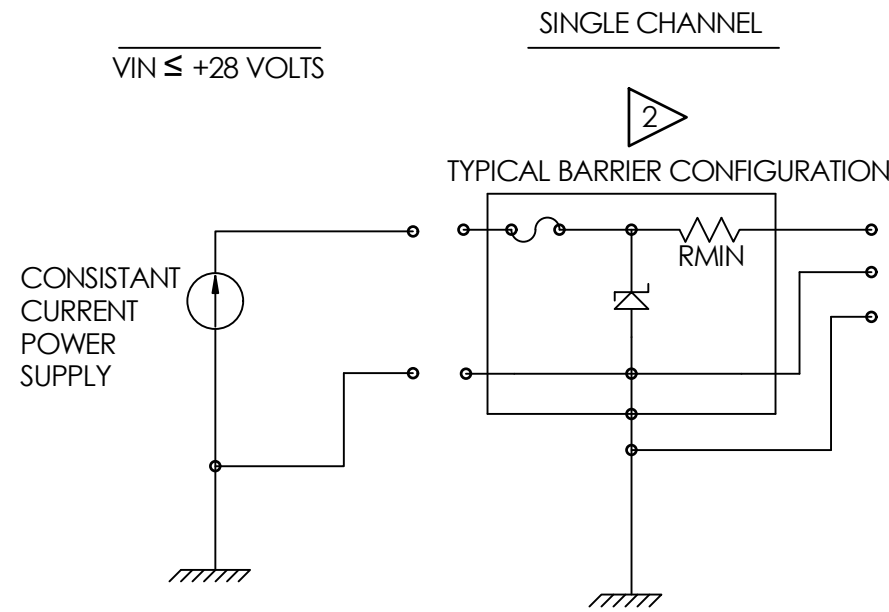

UNLESS OTHERWISE SPECIFIED
DIMENSIONS ARE IN INCHES
DECIMALS
x ± .05
xx ± .01
xxx ± .005
xxxx ± .0005
ANGLES ± 2 DEGREES
FILLETS AND RADII .003 - .005
HEX DIMENSIONS ARE:
≤ .5 + .000 / - .003
> .5 + .000 / - .005
INTERNAL THREAD DEPTH MIN.
REMOVE ALL BURRS
SHARP = R.000 - R.003

DRAWN	CHECKED	ENGINEER
JJF 3/16/20	JJF 3/16/20	GGG 3/16/20
TITLE		
ATEX/IECE _x INTERCONNECTION		

PCB PIEZOTRONICS™

3425 WALDEN AVE. DEPEW, NY 14043
 (716) 684-0002 E-MAIL: sales@pcb.com

CODE IDENT. NO. 52681	DWG. NO. 62544
SCALE: NONE	SHEET 1 OF 2

PCB Piezotronics Inc. claims proprietary rights in the information disclosed hereon. Neither it nor any reproduction thereof will be disclosed to others without the written consent of PCB Piezotronics Inc.

62544

RELATED DRAWING

NO MODIFICATIONS PERMITTED WITHOUT THE APPROVAL OF THE AUTHORIZED PERSON

REVISIONS

REV	DESCRIPTION	DIN
	-SEE SHEET 1-	

HAZARDOUS AREA/ ZONE 2

CABLE

EX682YYYY

APPROVED SENSOR

APPROVED POWER SUPPLY/
SIGNAL CONDITIONER

VIN ≤ +28 VOLTS
CONSTANT CURRENT
POWER SUPPLY

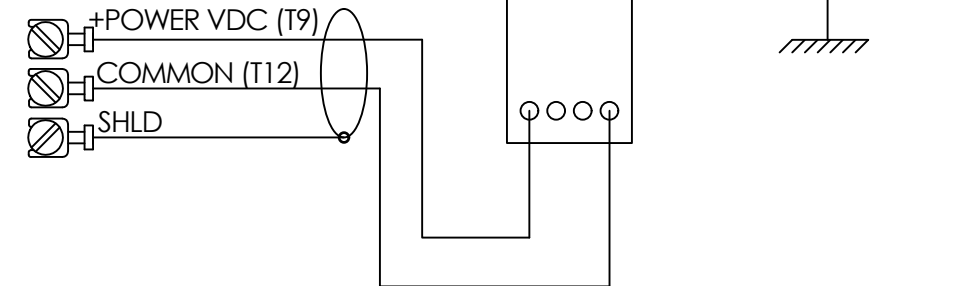
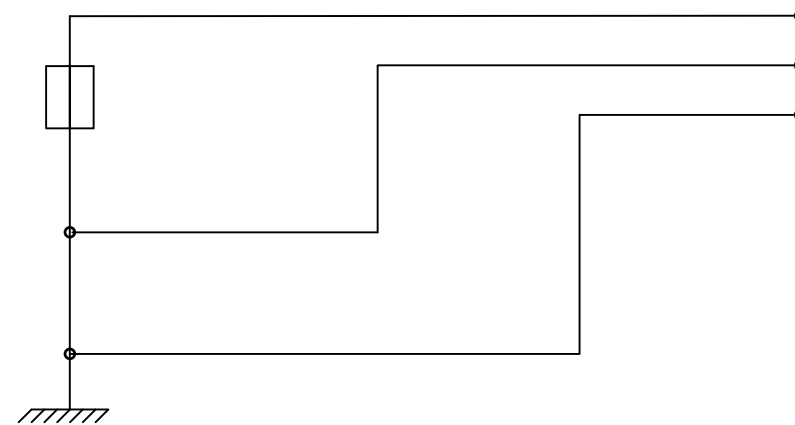

4.) MODEL NUMBER EX682YYYY CERTIFICATE:
LCIE 13 ATEX 1010 X
LCIE 13 ATEX 3031 X
IECEX LCIE 13.0002X

3.) ENTITY PARAMETERS (POWER SUPPLY):
U_i = 28V
I_i = 100mA
P_i = 0.7W

2.) MAXIMUM VOLTAGE OF POWER SUPPLY/SIGNAL CONDITIONER NEVER TO EXCEED 250 V_{rms}.



1.) CERTIFIED BY THE APPROPRIATE APPROVAL AUTHORITY FOR CONNECTION TO THE FOLLOWING AREAS:
ZONE 0
EX nA IIC T4 Gc
UNLESS OTHERWISE SPECIFIED

UNLESS OTHERWISE SPECIFIED	
DIMENSIONS ARE IN INCHES	
DECIMALS	X ± .05
	XX ± .01
	XXX ± .005
	XXXX ± .0005
ANGLES ± 2 DEGREES	
FILLETS AND RADII .003 - .005	
HEX DIMENSIONS ARE:	
	≤ .5 + .000 / - .003
	> .5 + .000 / - .005
INTERNAL THREAD DEPTH MIN. REMOVE ALL BURRS SHARP = R.000 - R.003	

DRAWN		CHECKED		ENGINEER	
JJF	3/16/20	JJF	3/16/20	GGG	3/16/20
TITLE					
ATEX/IECE _X INTERCONNECTION					

PCB PIEZOTRONICS™
3425 WALDEN AVE. DEPEW, NY 14043
(716) 684-0002 E-MAIL: sales@pcb.com

CODE IDENT. NO. 52681	DWG. NO. 62544
SCALE: NONE	SHEET 2 OF 2

Model Number EX682A40	DIFFERENTIAL DIN RAIL CHARGE AMPLIFIER		Revision: A ECN #: 42284					
Performance Sensitivity(+/-5 %) Input Range Low Frequency Response(+/-5 %) High Frequency Response(+/-5 %) Amplitude Linearity	ENGLISH 10 mV/pC +/-250 pC 5 Hz 10 kHz ≤ 1 %	SI 10 mV/pC +/-250 pC 5 Hz 10 kHz ≤ 1 %	<p align="center">OPTIONAL VERSIONS</p> <p>Optional versions have identical specifications and accessories as listed for the standard model except where noted below. More than one option may be used.</p>					
Environmental Hazardous Area Approval Hazardous Area Approval Hazardous Area Approval Hazardous Area Approval Hazardous Area Approval Hazardous Area Approval Hazardous Area Approval Temperature Range(Operating) Temperature Response Relative Humidity(Non Condensing)	IECEX LCIE 130002X LCIE 13 ATEX 3031X Ex ia IIC T4 Ga LCIE 13 ATEX 1010X Ex nA IIC T4 Gc Class I Div 1 Groups A, B, C, D Class I Div 2 Groups A, B, C, D -40 to +176 °F ≤ 1 % <95 %	IECEX LCIE 130002X LCIE 13 ATEX 3031X Ex ia IIC T4 Ga LCIE 13 ATEX 1010X Ex nA IIC T4 Gc Class I Div 1 Groups A, B, C, D Class I Div 2 Groups A, B, C, D -40 to 80 °C ≤ 1 % <95 %						
Electrical Excitation Voltage Constant Current Excitation Output Voltage Output Bias Voltage Broadband Electrical Noise(1 to 10,000 Hz) Spectral Noise(1 Hz) Spectral Noise(10 Hz) Spectral Noise(100 Hz) Spectral Noise(1 kHz) Spectral Noise(10 kHz) Discharge Time Constant Resistance Source Capacitance Loading Output in Relation to Input	22 to 28 VDC 3.1 to 4.1 mA +/-2.5 Vpk 10 to 12 VDC 200 μV 50 μV/√Hz 15 μV/√Hz 5 μV/√Hz 2 μV/√Hz 2 μV/√Hz >0.25 sec >50,000 Ohm 0.0003 %/pF In Phase	22 to 28 VDC 3.1 to 4.1 mA +/-2.5 Vpk 10 to 12 VDC 200 μV 50 μV/√Hz 15 μV/√Hz 5 μV/√Hz 2 μV/√Hz 2 μV/√Hz >0.25 sec >50,000 Ohm 0.0003 %/pF In Phase	<p>NOTES: [1] Typical value. [2] Tested using voltage source and input capacitor equal to the feedback capacitor, to simulate a charge output sensor. [3] See PCB Declaration of Conformance PS123 for details.</p>					
Physical Electrical Connector(Input) Electrical Connector(Output) Weight Mounting Case Material	Terminal Strip Terminal Strip 5.1 oz DIN Rail Injected Molded Nylon	Terminal Strip Terminal Strip 145 gm DIN Rail Injected Molded Nylon						
 [3]			<table border="1"> <tr> <td>Entered: AP</td> <td>Engineer: gs</td> <td>Sales: BRS</td> <td>Approved: BAM</td> <td>Spec Number:</td> </tr> </table>	Entered: AP	Engineer: gs	Sales: BRS	Approved: BAM	Spec Number:
Entered: AP	Engineer: gs	Sales: BRS	Approved: BAM	Spec Number:				
<p><i>All specifications are at room temperature unless otherwise specified. In the interest of constant product improvement, we reserve the right to change specifications without notice.</i></p> <p>ICP® is a registered trademark of PCB Group, Inc.</p>			<table border="1"> <tr> <td>Date: 12/11/2013</td> <td>Date: 12/11/2013</td> <td>Date: 12/11/2013</td> <td>Date: 12/11/2013</td> <td align="center">57012</td> </tr> </table> <p>PCB PIEZOTRONICS™ 3425 Walden Avenue, Depew, NY 14043</p> <p align="right"> Phone: 716-684-0001 Fax: 716-684-0987 E-Mail: info@pcb.com </p>	Date: 12/11/2013	Date: 12/11/2013	Date: 12/11/2013	Date: 12/11/2013	57012
Date: 12/11/2013	Date: 12/11/2013	Date: 12/11/2013	Date: 12/11/2013	57012				

PCB Piezotronics Inc. claims proprietary rights in the information disclosed hereon. Neither it nor any reproduction thereof will be disclosed to others without the written consent of PCB Piezotronics Inc.

57021

RELATED DRAWING

NO MODIFICATIONS PERMITTED WITHOUT THE APPROVAL OF THE AUTHORIZED PERSON

REVISIONS		
REV	DESCRIPTION	DIN
A	EX682 SERIES WAS EX682A40	50514

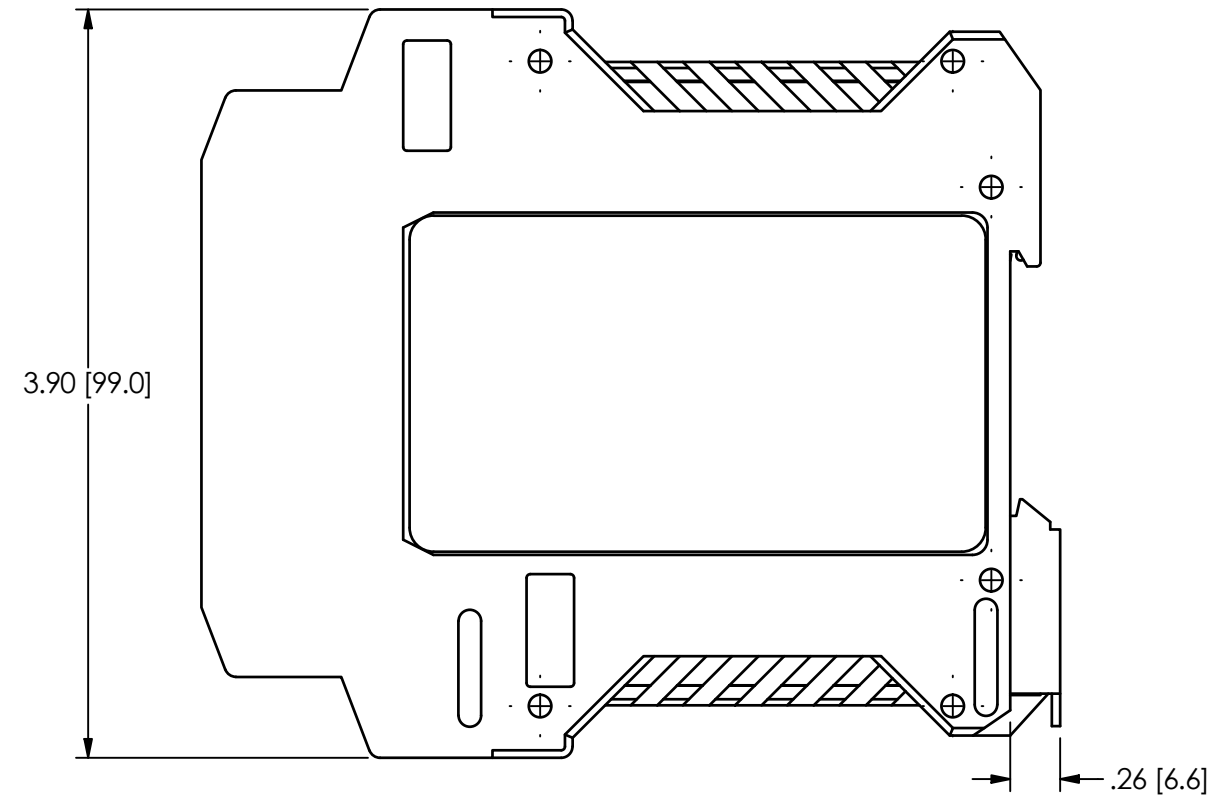
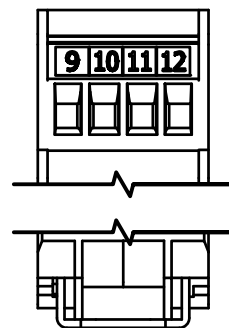
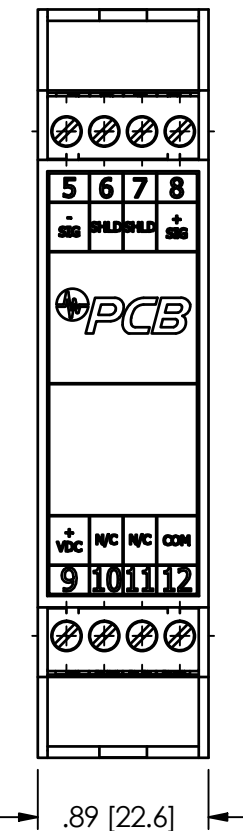
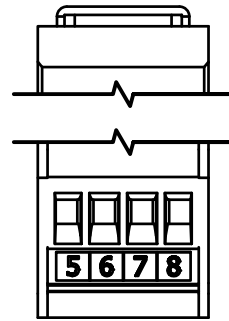
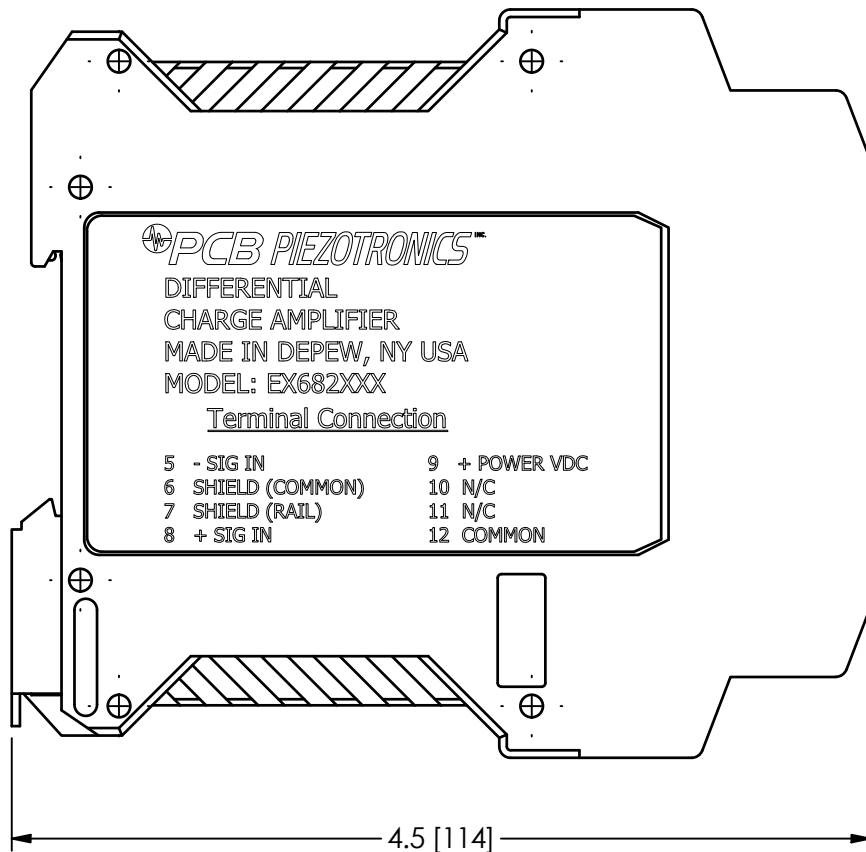

1.) HOUSING MATERIAL: INJECTION MOLDED NYLON 66 (POLYAMIDE) RATED UL 94-V0

UNLESS OTHERWISE SPECIFIED TOLERANCES ARE:		DRAWN		CHECKED		ENGINEER	
DIMENSIONS IN INCHES	DIMENSIONS IN MILLIMETERS [IN BRACKETS]	JJF	3/16/20	JJF	3/16/20	GGG	3/16/20
DECIMALS XX ±.03 XXX ±.010	DECIMALS X ±0.8 XX ±0.25	TITLE OUTLINE DRAWING MODEL EX682 SERIES AMPLIFIER					
ANGLES ± 2 DEGREES	ANGLES ± 2 DEGREES						
FILLETS AND RADII .003 - .005	FILLETS AND RADII 0.07 - 0.13	CODE IDENT. NO. 52681		DWG. NO. 57021		SCALE: FULL SHEET 1 OF 1	

PCB PIEZOTRONICS™
3425 WALDEN AVE. DEPEW, NY 14043
(716) 684-0001 E-MAIL: sales@pcb.com

INSTRUCTIONS FOR USE –EX682XYYY Series

Model(s)	EX682XYYY series where “X” is a letter that signifies family type. The letter will be from A to M. “YYY” is a number from 1 to 999 that signifies changes to filtering, gain frequency response etc..
Markings	PCB Depew, NY IECEX LCIE 13.0002X LCIE 13 ATEX 3031 X Ex ia IIC T4 Ga LCIE 13 ATEX 1010 X Ex nA IIC T4 Gc
Putting Into Service	<p>Powering: All Charge Amplifiers require constant current excitation for proper operation. For this reason, use only PCB constant-current signal conditioners or other approved constant-current sources. The power supply consists of a current-regulated, 18 to 30 VDC source. This power is regulated by a current-limiting circuit, which provides the constant-current excitation required for proper operation of Charge Amplifiers.</p> <p>In general, battery-powered devices offer versatility for portable, low-noise measurements, whereas line-powered units provide the capability for continuous monitoring. Consult the Vibration Division’s product catalog for more information about signal conditioners.</p> <p>NOTE: <i>Under no circumstances should a voltage be supplied to the Charge Amplifiers without a current-regulating diode or equivalent electrical circuit. This may include ohmmeters, multi-meters and continuity testers.</i></p>
Safe Use	<p>After completing the system setup, switch on the signal conditioner and allow 1 to 2 minutes for the system to stabilize. The meter (or LED) on the signal conditioner should be reading “green.” This indicates proper operation and you may begin taking measurements. If a faulty condition is indicated (red or yellow reading), first check all system connections, then check the functionality of the cable and signal conditioner. If the system still does not operate properly, consult a PCB factory representative.</p> <p>NOTE: <i>Always operate the Charge Amplifiers within the limitations listed on the enclosed Specification Sheet. Operating the device outside these parameters can cause temporary or permanent damage to the Charge Amplifiers.</i></p>
Assembling	The EX682XYYY Series have green polyamide housing and do not require any assembly. Only mounting on a 35mm Din Rail.
Dismantling	Other than removal from the mounting, there is no disassembly of the Charge Amplifiers required to take it out of service.
Maintenance	Routine maintenance, such as the cleaning of electrical connectors, housings, and mounting surfaces with solutions and techniques that will not harm the physical material of construction, is acceptable.
Servicing	Due to the sophisticated nature of the Charge Amplifiers and associated instrumentation provided by PCB Piezotronics, user servicing or repair is not recommended and, if attempted, may void the factory warranty. However, routine calibration of Charge Amplifiers and associated instrumentation is recommended as this helps build confidence in measurement accuracy and acquired data.
Repair	In the event that equipment becomes damaged or ceases to operate, arrangements should be made to return the equipment to PCB Piezotronics for repair. User servicing or repair is not recommended and, if attempted, may void the factory warranty.

 3425 Walden Ave Depew, New York 14043	<p>N^o 62271 N^o 1 of 2 Rev. A ECO #: 45736</p>
---	--

Installation	<p>Overview: The Charge Amplifiers are designed to be mounted on a 35mm Dain rail. Do note install in a harsh area where it can be exposed to cleaning fluid or machine oils. The unit should be mounted in a NEMA type enclosure to protect the electronics from contamination.</p> <p>Cabling: Care and attention to cable installation and cable condition is essential as the reliability and accuracy of any measurement system is no better than that of its weakest link. Due to the nature of vibration measurements, all Charge Amplifiers cables will ultimately fatigue and fail. Good installation practice will extend the life of a cable, however, it is highly recommended to keep spare cables on hand to enable continuation of the test in the event of a cable failure.</p>
Adjustment	No user adjustments are possible. However, routine calibration of Charge Amplifiers by the manufacturer is recommended as this helps build confidence in measurement accuracy and acquired data.
Danger Areas (for pressure-relief devices)	N/A – not a pressure relief device.
Training Instructions	Industrial Charge Amplifiers must be installed in Hazardous Locations by trained professionals according to EN/IEC 60079-14 requirements.
Details on Safety of Protection Category	Ex ia is “intrinsic safety”, which limits the energy of sparks and surface temperatures to safe levels Ex nA is “Non-Sparking”, which ensures that there is no risk of arcing and sparking or hot surfaces during normal operation.
Entity Parameters and Limits (Values)	<p>Temperature Range: -40°C to +85C</p> <p>Power Terminals (VDC, COM): $U_i \leq 28V$, $I_i \leq 100\text{ mA}$, $P_i \leq 0.7W$, $C_i=0$, $L_i = 0$</p> <p>Sensor Terminals (-SIG, +SIG, SHLD): $U_o \leq 28V$, $I_o \leq 60\text{ mA}$, $P_o \leq 0.42W$, $C_o=83nF$, $L_i = 10mH$</p>
Special Conditions of Use	<p>Version Ex ia :</p> <p>The equipment can be only connected to intrinsically safe certified equipment. These combinations must be compatible as regard the intrinsic safety rules (see electrical parameters)</p> <p>Version Ex nA:</p> <p>The user must comply with the requirements of the instructions for use. The component shall be installed in an enclosure conform to requirements of standard IEC 60079-0 and with ingress protection at least IP54.</p>
Essential Characteristics of tools fitted to the system (if any).	N/A – No tools are fitted to the system.
Drawings and Diagrams	54707,54708,54711,54712,54713,54714,65028,65092,54715,54716,54718
Other	

Note: Literature (such as the manual or marketing materials) describing the equipment or protective system must not contradict the instructions with regard to safety aspects.

 3425 Walden Ave Depew, New York 14043	<p>N^o 62271 N^o 2 of 2</p> <p>Rev. A</p> <p>ECO #: 45736</p>
---	--

PCB Piezotronics Inc. claims proprietary rights in the information disclosed hereon. Neither it nor any reproduction thereof will be disclosed to others without written consent of PCB Piezotronics Inc.

Schedule Drawing

No modifications permitted without reference to the Notified Body

REVISIONS		
REV	DESCRIPTION	ECO
NR	RELEASED TO DRAFTING	42284

56543

NO CHANGES WITHOUT CSA APPROVAL

NON-HAZARDOUS / SAFE AREA

HAZARDOUS AREA
DIV 1

5.) FOR GUIDANCE ON CANADIAN INSTALLATION, REFER TO CEC PART I. FOR GUIDANCE ON U.S. INSTALLATION, INSTALL IN ACCORDANCE WITH NEC [ANSI/NFPA70] AND [ANSI/ISA RP12.6].

4 SHIELDS TO BE EARTHED AT BARRIER END.

3 THE INSTALLER SHALL INSURE THAT THE SENSOR MOUNTING STRUCTURE IS AT THE SAME GROUNDING POTENTIAL AS THE BARRIER GROUND. TOTAL EARTH LOOP IMPEDANCE SHALL BE LESS THAN ONE OHM.

2 BARRIER WILL BE MOUNTED IN AN ENCLOSURE THE SUITABILITY OF WHICH WILL BE DETERMINED BY LOCAL AUTHORITIES.

1 ENTITY APPLICATION:

Barrier		I.S. Apparatus
V_{oc}/U_o	\leq	V_{MAX}/U_i
I_{sc}/I_o	\leq	I_{MAX}/I_i
C_a/C_o	$>$	$C_i + C_{CABLE}$
L_a/L_o	$>$	$L_i + L_{CABLE}$
P_o	\leq	P_i

BARRIERS WITHIN THE SPECIFIED LIMITATIONS ARE PERMITTED.

ENTITY PARAMETERS:

$U_i = 28\text{ V}$	$U_o = 28\text{ V}$
$I_i = 100\text{ mA}$	$I_o = 60\text{ mA}$
$P_i = 0.7\text{ W}$	$P_o = 0.42\text{ W}$
$C_i = 0\text{ nF}$	$C_o = 83\text{ nF}$
$L_i = 10.8\text{ uH}$	$L_o = 8\text{ mH}$

CERTIFIED BY THE APPROPRIATE APPROVAL AUTHORITY FOR CONNECTION TO THE FOLLOWING AREAS:

DIV 1
CLASS I, GROUPS A,B,C,D

NOTES: UNLESS OTHERWISE SPECIFIED.

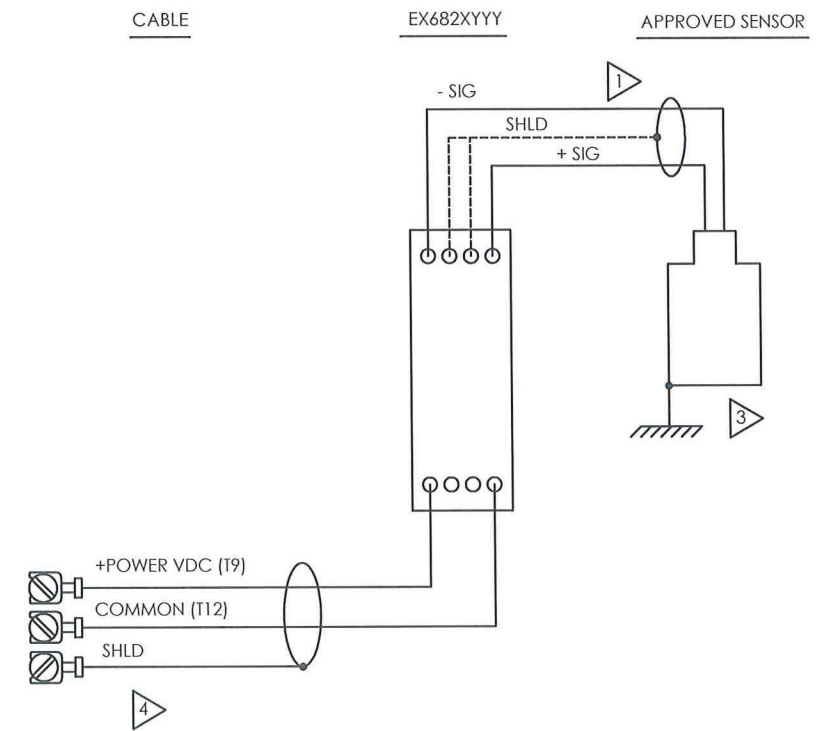
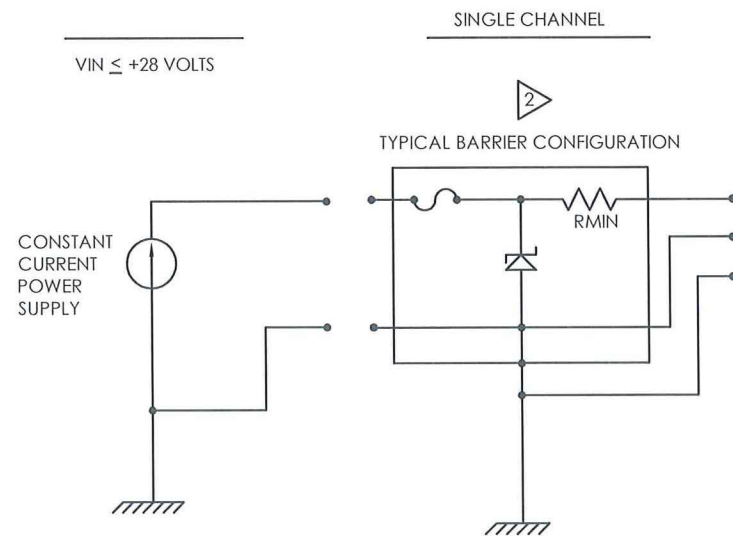

UNLESS OTHERWISE SPECIFIED
DIMENSIONS ARE IN INCHES
DECIMALS
X ± .05
XX ± .01
XXX ± .005
XXXX ± .0005
ANGLES 42 DEGREES
FILLETS AND RADII .003 - .005
HEX DIMENSIONS ARE:
< 0.5 +.000 / -.003
> 0.5 +.000 / -.005
INTERNAL THREAD DEPTH MIN
REMOVE ALL BURRS
SHARP = R.000 - R.003



DRAWN	CHECKED	ENGINEER
JDM 12/12/13	<i>[Signature]</i> 12/12/13	GGG 12/12/13

TITLE
CSA APPROVAL INTERCONNECTION



3425 WALDEN AVE. DEPEW, NY 14043
(716) 684-0001 EMAIL: SALES@PCB.COM

CODE IDENT. NO. 52681

DWG. NO. 56543

SCALE: NONE

SHEET 1 OF 2

PCB Piezotronics Inc. claims proprietary rights in the information disclosed hereon. Neither it nor any reproduction thereof will be disclosed to others without written consent of PCB Piezotronics Inc.

Schedule Drawing
No modifications permitted without reference to the Notified Body

REVISIONS		
REV	DESCRIPTION	ECO
	- SEE SHEET ONE -	

56543

NO CHANGES WITHOUT CSA APPROVAL

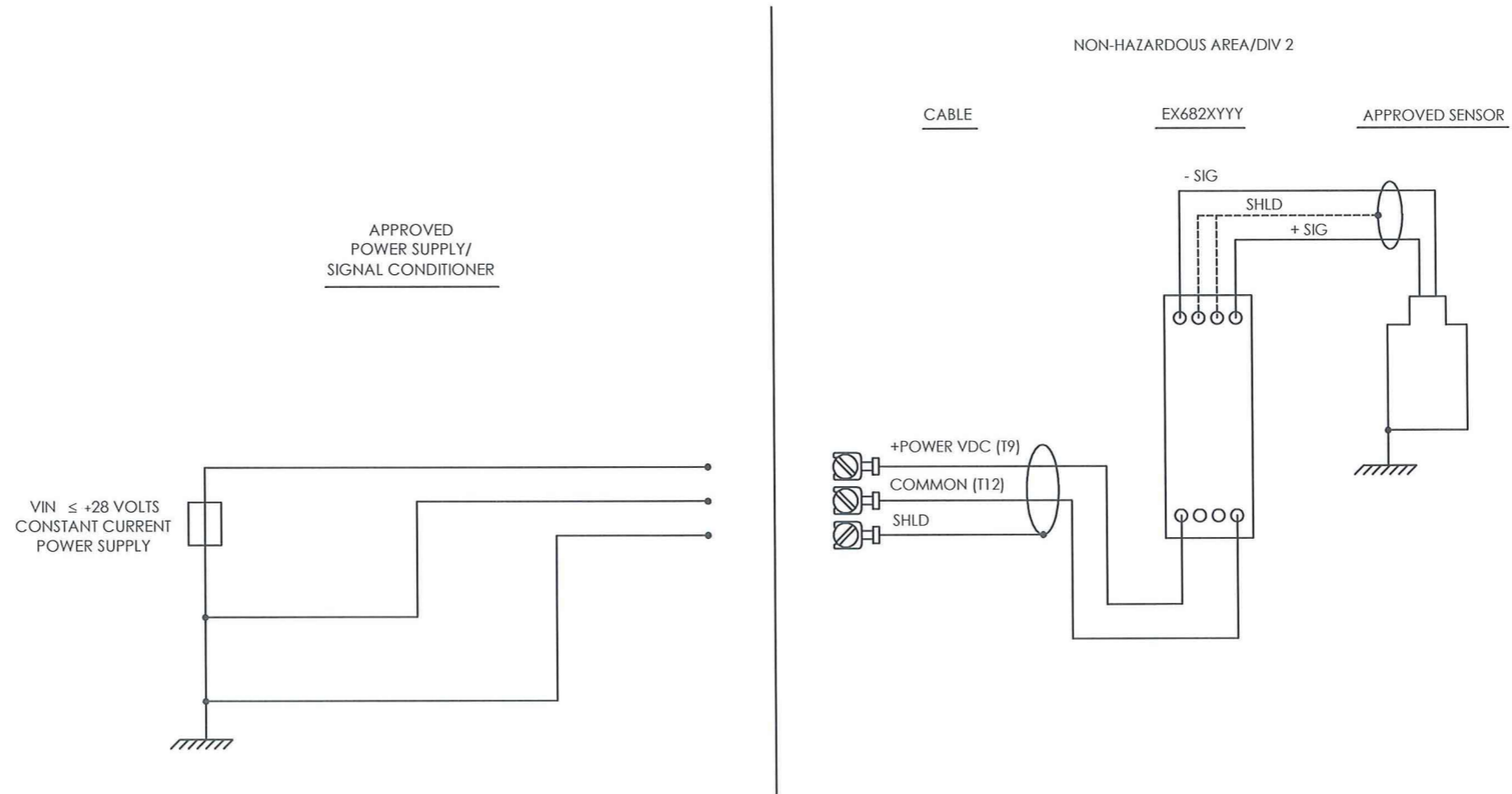

- FOR CANADIAN DIVISION 2 INSTALLATION, POWER SUPPLY MUST BE CSA CERTIFIED WITH ENTITY OUTPUT PARAMETERS (SEE PAGE 1 NOTE 1 FOR POWER SUPPLY OUTPUT PARAMETERS). FOR U.S. DIVISION 2 INSTALLATION, POWER SUPPLY MUST BE APPROVED BY NRTL WITH ENTITY OUTPUT PARAMETERS (SEE PAGE 1 NOTE 1 FOR POWER SUPPLY OUTPUT PARAMETERS).
- MAXIMUM VOLTAGE OF POWER SUPPLY/SIGNAL CONDITIONER NEVER TO EXCEED 250 Vrms.
- FOR GUIDANCE ON CANADIAN INSTALLATION, REFER TO CEC PART 1. FOR GUIDANCE ON U.S. INSTALLATION, INSTALL IN ACCORDANCE WITH NEC [ANSI/NFPA70] AND [ANSI/ISA RP12.6].
- CERTIFIED BY THE APPROPRIATE APPROVAL AUTHORITY FOR CONNECTION TO THE FOLLOWING AREAS:
DIV 2
CLASS I, GROUPS A,B,C,D

NOTES: UNLESS OTHERWISE SPECIFIED.

UNLESS OTHERWISE SPECIFIED
DIMENSIONS ARE IN INCHES
DECIMALS X ± .05
XX ± .01
XXX ± .005
XXXX ± .0005
ANGLES ±2 DEGREES
FILLETS AND RADII .003 - .005
HEX DIMENSIONS ARE:
< 0.5 +.000 / -.003
> 0.5 +.000 / -.005
INTERNAL THREAD DEPTH MIN
REMOVE ALL BURRS
SHARP = R.000 - R.003



DRAWN	CHECKED	ENGINEER
JDM 12/12/13	<i>gjm vls/p</i>	GGG 12/12/13

TITLE
CSA APPROVAL INTERCONNECTION

PCB PIEZOTRONICS
3425 WALDEN AVE. DEPEW, NY 14043
(716) 684-0001 EMAIL: SALES@PCB.COM

CODE IDENT. NO. 52681	DWG. NO. 56543
SCALE: NONE	SHEET 2 OF 2



제2020-000701-01-1호

안전인증서

PCB Piezotronics Inc.

3425 Walden Avenue, Depew, New York 14043, USA

위 사업장에서 제조하는 아래의 품목이 「산업안전보건법」 제34조 및 같은 법 시행규칙 제58조의4제4항에 따른 안전인증 심사 결과 안전·보건기준에 적합하므로 안전인증표시의 사용을 인증합니다.

품 목

Charge Amplifier

형식·모델(용량·등급) / 인증번호

EX682**(Ex nA IIC T4) / 19-KA4BO-0468X

인증기준

고용노동부고시 제2019-15호

인증조건

1. 제조공장

·본 인증서는 '3425 Walden Avenue, Depew, New York 14043, USA'에서 생산하는 제품에 한함.

2. 제품개요

·당 기기는 차동 출력 충전 센서와 인터페이스하도록 설계된 비점화 방폭구조의 차동 충전 입력 증폭기임.

·정격: $U = 28 \text{ V}$ 이하, $I = 100 \text{ mA}$ 이하, $P = 0.7 \text{ W}$ 이하

·사용주위온도: $-40 \text{ }^\circ\text{C} \leq T_a \leq +85 \text{ }^\circ\text{C}$

3. 인증범위

·본 인증서는 아래의 형식번호에 한하여 유효함

·EX682(a)(b)

·-(a): A~M, (b): 1~999

4. 안전한 사용을 위한 조건

·관련 IECEx 인증서(IECEx LCIE 13.0002X issue No.2) 3페이지 CONDITIONS OF CERTIFICATION 참조

5. 인증(변경)사항

·1차 변경(2020.01.10.): 기존 제2019-030174-01-1호에서 동일형식 추가에 따른 변경

6. 그 밖의 사항

·사용자 설명서 참조

·안전인증품의 품질관리, 확인심사 수검, 변경사항 신고 등 인증 받은 자의 의무 준수

·본 안전인증서는 반드시 관련 IECEx 인증서(IECEx LCIE 13.0002X issue No.2)와 함께 사용

2019년 7월 3일

한국산업기술시험원장



안전인증을 받은 자의 유의사항 [Notification for recipient (certification holder)]

1. 본 인증서는 기재된 사업장에서 생산된 제품으로서 적용된 안전인증기준에 적합한 경우에 한하여 유효합니다. (This certificate is valid only when the product is suitable for the applied safety certification criteria and is manufactured from the manufacturing location that is stipulated on this certificate)
2. 안전인증을 받은 자가 다음 각 호의 어느 하나에 해당하면 인증정지 및 취소의 사유가 됩니다. (If a person who has received safety certification falls under any of the following subclause, this safety certification may be suspended or cancelled)
 - 1) 거짓이나 그 밖의 부정한 방법으로 안전인증을 받은 경우 (In case of being certified in false or other improper ways)
 - 2) 안전인증을 받은 안전인증대상 기계기구등의 안전에 관한 성능 등이 안전인증기준에 맞지 아니하게 된 경우 (In the case that the properties of the product for which safety certification has been received are not suitable for the safety certification criteria)
 - 3) 정당한 사유 없이 확인심사를 거부, 기피 또는 방해하는 경우 (In case of refusing, avoiding or disturbing regular surveillance audit without a justifiable reason)
3. 다음과 같은 사유가 발생할 경우에는 안전인증기관에 안전인증 변경 신청을 하여 안전인증서를 재교부 받아야 합니다. (In the case of the following subclauses, the revision of the safety certification shall be applied to the safety certification body and the safety certificate shall be reissued)
 - 1) 인증서의 분실 또는 훼손 (Losses or damages to this certificate)
 - 2) 제조자, 주소, 인증조건 등 인증서 기재사항의 변경 (Changes of stated items in the certificate such as manufacturer's name, manufacturer's address, certification conditions, etc)
4. 안전인증을 받은 자는 다음 사항을 이행해야 합니다. (The recipient of safety certificate (certification holder) shall comply with the following subclauses)
 - 1) 안전인증표시 등 인증요건의 유지관리 (Maintenance control of the certification requirements such as a safety certification mark)
 - 2) 안전인증을 받기 이전 또는 정지, 취소된 이후 생산된 제품에 안전인증표시를 하면 법에 의거 처벌을 받게 됩니다. (It will be punished by the ACT if the safety certification mark is used before issue of the safety certification or after suspension or cancellation of the safety certification)
5. 안전인증을 받은 자는 산업안전보건법 제34조 5항 및 동법 시행규칙 제58조의5에 따라 정기적인 확인심사를 받아야 합니다. (The recipient of the safety certification (certification holder) shall receive a regular surveillance audit under Paragraph 5 of Article 34 of OCCUPATIONAL SAFETY AND HEALTH ACT and Article 58-5 of ENFORCEMENT ORDINANCE in the same ACT)

연락처(Contact information) : 서울 사무소(Seoul office) Tel +82-2-860-1540, Fax +82-2-860-1549
E-mail: kang@ktl.re.kr, Homepage: www.ktl.re.kr



L C I E

1 **ATTESTATION D'EXAMEN CE DE TYPE**

2 **Appareil ou système de protection** destiné à être utilisé en atmosphères explosibles (**Directive 94/9/CE**)

3 Numéro de l'attestation d'examen CE de type
LCIE 13 ATEX 3031 X

4 Appareil ou système de protection :
Amplificateur de charge
Type : EX682XYYY

5 Demandeur : PCB Piezotronics Inc.
Adresse : 3425 Walden Avenue
Depew, New York
14043 USA

6 Fabricant : PCB Piezotronics Inc.
Adresse : 3425 Walden Avenue
Depew, New York
14043 USA

7 Cet appareil ou système de protection et ses variantes éventuelles acceptées sont décrits dans l'annexe de la présente attestation et dans les documents descriptifs cités en référence.

8 Le LCIE, organisme notifié sous la référence 0081 conformément à l'article 9 de la directive 94/9/CE du Parlement européen et du Conseil du 23 mars 1994, certifie que cet appareil ou système de protection est conforme aux exigences essentielles de sécurité et de santé pour la conception et la construction d'appareils et de systèmes de protection destinés à être utilisés en atmosphères explosibles, données dans l'annexe II de la directive. Les résultats des vérifications et essais figurent dans le rapport confidentiel N°117214-634396.

9 Le respect des exigences essentielles de sécurité et de santé est assuré par la conformité à :

IEC 60079-0 Ed 6, EN 60079-11:2012

10 Le signe X lorsqu'il est placé à la suite du numéro de l'attestation, indique que cet appareil ou système de protection est soumis aux conditions spéciales pour une utilisation sûre, mentionnées dans l'annexe de la présente attestation.

11 Cette attestation d'examen CE de type concerne uniquement la conception et la construction de l'appareil ou du système de protection spécifié, conformément à l'annexe III de la directive 94/9/CE.

Des exigences supplémentaires de la directive sont applicables pour la fabrication et la fourniture de l'appareil ou du système de protection. Ces dernières ne sont pas couvertes par la présente attestation.

12 Le marquage de l'appareil ou du système de protection doit comporter les informations détaillées au point 15.

Fontenay-aux-Roses, le 14 juin 2013

1 **EC TYPE EXAMINATION CERTIFICATE**

2 **Equipment or protective system** intended for use in potentially explosive atmospheres (**Directive 94/9/EC**)

3 EC type examination certificate number
LCIE 13 ATEX 3031 X

4 Equipment or protective system :
Charge amplifier
Type : EX682XYYY

5 Applicant : PCB Piezotronics Inc.
Address : 3425 Walden Avenue
Depew, New York
14043 USA

6 Manufacturer : PCB Piezotronics Inc.
Address : 3425 Walden Avenue
Depew, New York
14043 USA

7 This equipment or protective system and any acceptable variation thereto are specified in the schedule to this certificate and the documents therein referred to.

8 LCIE, notified body number 0081 in accordance with article 9 of the Directive 94/9/EC of the European Parliament and the Council of 23 March 1994, certifies that this equipment or protective system has been found to comply with the essential Health and Safety Requirements relating to the design and construction of equipment and protective systems intended for use in potentially explosive atmospheres, given in Annex II to the Directive. The examination and test results are recorded in confidential report N°117214-634396.

9 Compliance with the Essential Health and Safety Requirements has been assured by compliance with :

10 If the sign X is placed after the certificate number, it indicates that the equipment or protective system is subject to special conditions for safe use specified in the schedule to this certificate.

11 This EC type examination certificate relates only to the design and construction of this specified equipment or protective system in accordance with annex III to the directive 94/9/EC.

Further requirements of the directive apply to the manufacturing process and supply of this equipment or protective system. These are not covered by this certificate.

12 The marking of the equipment or protective system shall include the information as detailed at 15.



Responsable de Certification ATEX
ATEX Certification Officer
Julien GAUTHIER

Seul le texte en français peut engager la responsabilité de LCIE. Ce document ne peut être reproduit que dans son intégralité, sans aucune modification.
Only the French text can engage the liability of LCIE. This document may only be reproduced in its entirety and without any change

01-Annexe III_CE_typ_app - rev2.DOC
Page 1 of 2



LCIE

13 ANNEXE

14 ATTESTATION D'EXAMEN CE DE TYPE

LCIE 13 ATEX 3031 X

15 DESCRIPTION DE L'APPAREIL OU DU SYSTEME DE PROTECTION

Amplificateur de charge
Type : EX682XYYY

L'amplificateur de charge fournit une tension de sortie à partir d'une charge d'entrée.

Définition du type :

X : désignation du type (A,B,...M)

YYY : filtrage, gain, réponse en fréquence,... (1 à 999)

Paramètres spécifiques du ou des modes de protection concernés :

Bornes d'alimentation (VDC, COM) :

$U_i \leq 28V$, $I_i \leq 100mA$, $P_i \leq 0,7W$, $C_i = 0$, $L_i = 0$

Bornes capteur (-SIG, +SIG, SHLD) :

$U_o \leq 28V$, $I_o \leq 60mA$, $P_o \leq 0,42W$, $C_o \leq 83nF$, $L_o \leq 10mH$

Le marquage doit être :

PCB Adresse : ...

Type : EX682XYYY (1)

N° de fabrication : ... Année de fabrication : ...

⊕ II 1 G

Ex ia IIC T4 Ga

LCIE 13 ATEX 3031 X

$-40^\circ C \leq T_{amb} \leq +85^\circ C$

Bornes d'alimentation (VDC, COM) :

$U_i \leq 28V$, $I_i \leq 100mA$, $P_i \leq 0,7W$, $C_i = 0$, $L_i = 0$

Bornes capteur (-SIG, +SIG, SHLD) :

$U_o \leq 28V$, $I_o \leq 60mA$, $P_o \leq 0,42W$, $C_o \leq 83nF$, $L_o \leq 10mH$

(1)complété en fonction du modèle

L'appareil doit également comporter le marquage normalement prévu par les normes de construction qui le concerne.

16 DOCUMENTS DESCRIPTIFS

Dossier de certification N°54707 du 12/04/2013.

Ce dossier comprend 6 rubriques (10 pages).

17 CONDITIONS SPECIALES POUR UNE UTILISATION SÛRE

L'appareil ne peut être raccordé qu'à des équipements certifiés de sécurité intrinsèque. Ces associations doivent être compatibles vis-à-vis de la sécurité intrinsèque (voir les paramètres électriques au paragraphe 15).

18 EXIGENCES ESSENTIELLES DE SECURITE ET DE SANTE

Couvertes par les normes listées au point 9.

19 VERIFICATIONS ET ESSAIS INDIVIDUELS

Néant.

20 CONDITIONS DE CERTIFICATION

Les détenteurs d'attestations d'examen CE de type doivent également satisfaire les exigences de contrôle de production telles que définies à l'article 8 de la directive 94/9/CE.

13 SCHEDULE

14 EC TYPE EXAMINATION CERTIFICATE

LCIE 13 ATEX 3031 X

15 DESCRIPTION OF EQUIPMENT OR PROTECTIVE SYSTEM

Charge amplifier
Type : EX682XYYY

The charge amplifier provides a voltage output from a charge input.

Type definition :

X : family type (A,B,...M)

YYY : filtering, gain, frequency response,... (1 to 999)

Specific parameters of the concerned protection mode:

Power terminals (VDC, COM) :

$U_i \leq 28V$, $I_i \leq 100mA$, $P_i \leq 0,7W$, $C_i = 0$, $L_i = 0$

Sensor terminals (-SIG, +SIG, SHLD) :

$U_o \leq 28V$, $I_o \leq 60mA$, $P_o \leq 0,42W$, $C_o \leq 83nF$, $L_o \leq 10mH$

The marking shall be :

PCB Address : ...

Type : EX682XYYY (1)

Serial number : ... Year of construction : ...

⊕ II 1 G

Ex ia IIC T4 Ga

LCIE 13 ATEX 3031 X

$-40^\circ C \leq T_{amb} \leq +85^\circ C$

Power terminals (VDC, COM) :

$U_i \leq 28V$, $I_i \leq 100mA$, $P_i \leq 0,7W$, $C_i = 0$, $L_i = 0$

Sensor terminals (-SIG, +SIG, SHLD) :

$U_o \leq 28V$, $I_o \leq 60mA$, $P_o \leq 0,42W$, $C_o \leq 83nF$, $L_o \leq 10mH$

(1)completed according to the model

The equipment shall also bear the usual marking required by the manufacturing standards applying to such equipment.

16 DESCRIPTIVE DOCUMENTS

Certification file N°54707 dated 2013/04/12.

This file includes 6 items (10 pages).

17 SPECIAL CONDITIONS FOR SAFE USE

The equipment can be only connected to intrinsically safe certified equipment. These combinations must be compatible as regard the intrinsic safety rules (see electrical parameters clause 15).

18 ESSENTIAL HEALTH AND SAFETY REQUIREMENTS

Covered by standards listed at 9.

19 ROUTINE VERIFICATIONS AND TESTS

None.

20 CONDITIONS OF CERTIFICATION

Holders of EC type examination certificates are also required to comply with the production control requirements defined in article 8 of directive 94/9/EC.

Certificate of Compliance

Certificate: 2646142 Master Contract: 184981 (103164_0_000)

Project: 70086425 Date Issued: 2016-10-27

Issued to: Industrial Monitoring Instr. (IMI) A Div. of PCB Piezotronics, Inc.
3425 Walden Ave
Depew, New York 14043
USA
Attention: Carrie Termin

The products listed below are eligible to bear the CSA Mark shown

Issued by: *Konstantin Rybalko*
Konstantin Rybalko

PRODUCTS

CLASS - C225803 - PROCESS CONTROL EQUIPMENT - Intrinsically Safe and Non-Incendive Systems - For Hazardous Locations

CLASS - C225883 - PROCESS CONTROL EQUIPMENT-Intrinsically Safe and Non-Incendive-Systems- For Hazardous Locations-Certified to U.S. Standards

Class I, Division 1, Groups A, B, C and D:

- Model EX682XYYYY Differential Charge Amplifier, input rated 28 Vdc max, 20 mA max; intrinsically safe with entity parameters at Power terminals (VDC, COM): $V_{max}(U_i) \leq 28V$, $I_{max}(I_i) \leq 100mA$, $P_i \leq 0.7W$, $L_i = 10.8 \mu H$, $C_i = 0 \eta F$; Sensor terminals (-SIG, +SIG): $V_{oc}(U_o) \leq 28V$, $I_{sc}(I_o) \leq 60mA$, $P_o \leq 0.42W$, $L_o = 8mH$, $C_o = 83 \eta F$. Intrinsically safe when installed per installation Dwg. 56543; Temperature Code T4 at maximum ambient 85°C.

Notes:

1. The Model EX682XYYYY shall be installed in a suitable enclosure acceptable to CSA or the local authority having jurisdiction.
2. The Model EX682XYYYY can only be connected to intrinsically safe Certified equipment per installation drawing.

ITEM # 57701
REV. A
ECO 46172

The Model codes suffixes are as follows:

X = family type: A – M

YYYY = different filtering, gain, frequency response: 0-9999.

Class I, Division 2, Groups A, B, C and D:

- Model EX682XXXXX Differential Charge Amplifier, input rated 28 Vdc max, 20mA max; non-incendive with entity parameters at Power terminals (VDC, COM): $V_{max} (U_i) \leq 28V$, $I_{max} (I_i) \leq 100mA$, $P_i \leq 0.7 W$, $L_i = 10.8 \mu H$, $C_i = 0 \eta F$; Sensor terminals (-SIG, +SIG): $V_{oc} (U_o) \leq 28V$, $I_{sc} (I_o) \leq 60 mA$, $P_o \leq 0.42W$, $L_o \leq 8 mH$, $C_o \leq 83 \eta F$. Refer to installation Dwg. 56543; Temperature Code T4 at maximum ambient 85°C.

Notes:

1. The Model EX682XXXXX shall be installed in a suitable enclosure acceptable to CSA or the local authority having jurisdiction.
2. The Model EX682XXXXX shall only be connected to non-incendive Certified equipment per installation drawing.

The Model codes suffixes are as follows:

X = family type: A – M

YYYY = different filtering, gain, frequency response: 0-9999.

APPLICABLE REQUIREMENTS

- | | |
|---------------------------------|---|
| CAN/CSA-C22.2 No. 0-2010 | - General Requirements – Canadian Electrical Code, Part II |
| C22.2 No. 142-M1987 (R2009) | - Process Control Equipment |
| CAN/CSA-C22.2 No.157-92 (R2012) | - Intrinsically Safe and Non-Incendive Equipment for Use in Hazardous Locations |
| C22.2 No. 213-M1987 (R2008) | - Non-Incendive Electrical Equipment for Use in Class I, Division 2 Hazardous Locations |
| UL 913-5 th Edition | - Intrinsically Safe Apparatus and Associated Apparatus for Use in Class I, II and III, Division 1, Hazardous Locations |
| UL 916-4 th Edition | - Energy Management Equipment |
| ANSI/ISA 12.12.01-2012 | - Nonincendive Electrical Equipment for Use in Class I and II, Division 2 and Class III, Divisions 1 and 2 Hazardous (Classified) Locations |

Supplement to Certificate of Compliance

Certificate: 2646142

Master Contract: 184981 (103164_0_000)

*The products listed, including the latest revision described below,
are eligible to be marked in accordance with the referenced Certificate.*

Product Certification History

Project	Date	Description
70086425	2016-10-27	Update to report 2646142 to include schematic change.
2646142	2013-11-08	Original Certification of EX682XXXXX



LCIE

ATTESTATION D'EXAMEN DE TYPE TYPE EXAMINATION CERTIFICATE



1 Version : 01

LCIE 13 ATEX 1010 X

Issue : 01

Directive 2014/34/UE

Directive 2014/34/EU

2 Appareil ou Système de Protection destiné à être utilisé en Atmosphères Explosibles

Equipment or Protective System Intended for use in Potentially Explosive Atmospheres

3 Produit :
Amplificateur de charge

Product :
Charge amplifier

Type: EX682XYYY

4 Fabricant :

Manufacturer :

PCB Piezotronics Inc.

5 Adresse :

Address :

3425 Walden Avenue
Depew, New York 14043
USA

6 Ce produit et ses variantes éventuelles acceptées sont décrits dans l'annexe de la présente attestation et dans les documents descriptifs cités en référence.

This product any acceptable variation thereto is specified in the schedule to this certificate and the documents therein referred to.

7 Le LCIE certifie que ce produit est conforme aux Exigences Essentielles de Sécurité et de Santé pour la conception et la construction de produits destinés à être utilisés en atmosphères explosibles, données dans l'annexe II de la Directive.
Les résultats des vérifications et essais figurent dans le(s) rapport(s) confidentiel(s) N° :

LCIE certifies that product has been found to comply with the Essential Health and Safety Requirements relating to the design and construction of products intended for use in potentially explosive atmospheres, given in Annex II to the Directive.
The examination and test results are recorded in confidential report(s) N°:

117214-634396, 143150-689115.

8 Le respect des Exigences Essentielles de Sécurité et de Santé est assuré par la conformité à :

Compliance with the Essential Health and Safety Requirements has been assured by compliance with :

EN 60079-0:2012 +A11:2013, EN 60079-15:2010

9 Le signe « X » lorsqu'il est placé à la suite du numéro de l'attestation, indique que cet appareil est soumis aux conditions particulières d'utilisation, mentionnées dans l'annexe de cette attestation.

If the sign "X" is placed after the certificate number, it indicates that the product is subject to the Specific Conditions of Use specified in the schedule to this certificate.

10 Cette Attestation d'Examen de Type concerne uniquement la conception et la construction du produit spécifié.
Des exigences supplémentaires de la directive sont applicables pour la fabrication et la fourniture du produit. Ces dernières ne sont pas couvertes par la présente attestation.

This Type Examination Certificate relates only to the design and construction of the specified product.
Further requirements of the Directive apply to the manufacturing process and supply of this product. These are not covered by this certificate.

11 Le marquage du produit est mentionné dans l'annexe de cette attestation.

The marking of the product is specified in the schedule to this certificate.

Fontenay-aux-Roses, le 30 septembre 2016

Responsable de Certification
Certification Officer

Julien Gauthier



Seul le texte en français peut engager la responsabilité du LCIE. Ce document ne peut être reproduit que dans son intégralité, sans aucune modification. Il est établi en accord avec le référentiel de certification ATEX du LCIE. The LCIE's liability applies only on the French text. This document may only be reproduced in its entirety and without any change. It is issued in accordance with LCIE's ATEX Certification Rules.
CERT-ATEX-FORM 05 Rev. 02

Page 1 of 3

LCIE

Laboratoire Central des Industries Electriques
Une société de Bureau Veritas

33 Avenue du Général Leclerc
92260 Fontenay-aux-Roses
FRANCE

WWW.LCIE.FR



ATTESTATION D'EXAMEN DE TYPE - ANNEXE

TYPE EXAMINATION CERTIFICATE - SCHEDULE

1 Version : 01

LCIE 13 ATEX 1010 X

Issue : 01

12 DESCRIPTION DU PRODUIT

L'amplificateur de charge fournit une tension de sortie à partir d'une charge d'entrée.

DETAIL DE LA GAMME

Définition du type :
EX682XXXX
X : désignation du type (A, B,...M)
YYY : filtrage, gain, réponse en fréquence,... (1 à 999)

Paramètres spécifiques du ou des modes de protection concernés :

$U \leq 28V, I \leq 100mA, P \leq 0.7W$

MARQUAGE

Le marquage du produit doit comprendre :

PCB Piezotronics Inc.
Adresse : ...
Type : EX682XXXX⁽¹⁾
Numéro de fabrication : ...
Année de construction : ...

II 3 G

Ex nA IIC T4 Gc
LCIE 13 ATEX 1010 X
 $-40^{\circ}C \leq T_{amb} \leq +85^{\circ}C$

⁽¹⁾ complété en fonction du modèle

L'appareil doit également comporter le marquage normalement prévu par les normes de construction qui le concernent sous la responsabilité du fabricant.

DESCRIPTION OF PRODUCT

The charge amplifier provides a voltage output from a charge input.

RANGE DETAILS

Type definition :
EX682XXXX
X : family type (A, B,...M)
YYY : filtering, gain, frequency response,... (1 to 999)

Specific parameters of the concerned protection mode :

MARKING

The marking of the product shall include the following :

PCB Piezotronics Inc.
Address: ...
Type : EX682XXXX⁽¹⁾
Serial number: ...
Year of construction: ...

II 3 G

Ex nA IIC T4 Gc
LCIE 13 ATEX 1010 X
 $-40^{\circ}C \leq T_{amb} \leq +85^{\circ}C$

⁽¹⁾ completed according to the model

The equipment shall also bear the usual marking required by the product standards applying to such equipment under the manufacturer responsibility.

13 CONDITIONS PARTICULIERES D'UTILISATION

Le composant doit être installé dans une enveloppe conforme aux exigences de la norme EN 60079-0 et ayant un degré de protection minimal IP54.

SPECIFIC CONDITIONS OF USE

The component shall be installed in an enclosure conforming to the requirements of standard EN 60079-0 and with ingress protection at least IP54.

14 EXIGENCES ESSENTIELLES DE SANTE ET DE SECURITE

Couvertes par les normes listées au point 8.

ESSENTIAL HEALTH AND SAFETY REQUIREMENTS

Covered by standards listed at 8.

15 DOCUMENTS DESCRIPTIFS

N°	Description	Reference	Rev.	Date	Page(s)
1.	Instructions	62771	A	/	2
2.	Technical file	54707	A	2016/10/08	12

DESCRIPTIVE DOCUMENTS

16 INFORMATIONS COMPLEMENTAIRES

Essais individuels

Néant.

En accord avec l'Article 41 de la Directive 2014/34/UE, les attestations d'examen de type mentionnant la Directive 94/9/CE émises avant la date d'application de la Directive 2014/34/UE (20 avril 2016) peuvent être considérées comme émises en accord avec la Directive 2014/34/UE. Les nouvelles versions de ces attestations peuvent conserver le numéro de l'attestation d'origine émise avant le 20 avril 2016.

ADDITIONAL INFORMATIONS

Routine tests

None.

In accordance with Article 41 of Directive 2014/34/EU, Type Examination Certificates referring to Directive 94/9/EC that were in existence prior to the date of application of Directive 2014/34/EU (20 April 2016) may be referenced as if they were issued in accordance with Directive 2014/34/EU. New issues of such certificates may continue to bear the original certificate number issued prior to 20 April 2016.

Seul le texte en français peut engager la responsabilité du LCIE. Ce document ne peut être reproduit que dans son intégralité, sans aucune modification. Il est établi en accord avec le référentiel de certification ATEX du LCIE. The LCIE's liability applies only on the French text. This document may only be reproduced in its entirety and without any change. It is issued in accordance with LCIE's [ATEX Certification Rules](#).
CERT-ATEX-FORM 05 Rev. 02

Page 2 of 3

LCIE

Laboratoire Central des Industries Electriques
Une société de Bureau Veritas

33 Avenue du Général Leclerc
92260 Fontenay-aux-Roses
FRANCE

WWW.LCIE.FR



ATTESTATION D'EXAMEN DE TYPE - ANNEXE

TYPE EXAMINATION CERTIFICATE - SCHEDULE

1 Version : 01

LCIE 13 ATEX 1010 X

Issue : 01

17 DETAILS DES MODIFICATIONS

Version00 : Evaluation initial
14/06/2013

Version 01 : Ajout d'un nouveau modèle (EX682M78).

DETAILS OF CHANGES

Issue 00 : Initial assessment
2013/06/14

Issue 01 : Addition of a new model (EX682M78).

Seul le texte en français peut engager la responsabilité du LCIE. Ce document ne peut être reproduit que dans son intégralité, sans aucune modification. Il est établi en accord avec le [référentiel de certification ATEX](#) du LCIE. *The LCIE's liability applies only on the French text. This document may only be reproduced in its entirety and without any change. It is issued in accordance with LCIE's [ATEX Certification Rules](#).*
CERT-ATEX-FORM 05 Rev. 02

Page 3 of 3

LCIE

Laboratoire Central des Industries Electriques
Une société de Bureau Veritas

33 Avenue du Général Leclerc
92260 Fontenay-aux-Roses
FRANCE

WWW.LCIE.FR



L C I E

1 ATTESTATION D'EXAMEN DE TYPE VOLONTAIRE

2 Appareil destiné à être utilisé en atmosphères explosibles (Directive 94/9/CE)

3 Numéro de l'attestation d'examen de type **LCIE 13 ATEX 1010 X**

4 Appareil

Amplificateur de charge

Type : EX682XYYY

5 Demandeur : PCB Piezotronics Inc.

Adresse : 3425 Walden Avenue

Depew, New York

14043 USA

7 Cet appareil ou système de protection et ses variantes éventuelles acceptées sont décrits dans l'annexe de la présente attestation et dans les documents descriptifs cités en référence.

8 Le LCIE certifie que cet appareil ou système de protection est conforme aux exigences essentielles de sécurité et de santé pour la conception d'appareils ou système de protection, électriques de catégorie 3 ou non électriques de catégorie 2 et 3, destinés à être utilisés en atmosphères explosibles, données dans l'annexe II de la directive 94/9/CE du Parlement européen et du Conseil du 23 mars 1994.

Les résultats des vérifications et essais figurent dans le rapport confidentiel N°117214-634396.

9 Le respect des exigences essentielles de sécurité et de santé est assuré par la conformité à :

IEC 60079-0 Ed 6, EN 60079-15:2010

10 Le signe X lorsqu'il est placé à la suite du numéro de l'attestation, indique que cet appareil ou système de protection est soumis aux conditions spéciales pour une utilisation sûre, mentionnées dans l'annexe de la présente attestation.

11 Cette attestation d'examen de type concerne uniquement la conception, les vérifications et essais de l'appareil ou du système de protection spécifié, conformément à la directive 94/9/CE.

Des exigences supplémentaires de la directive sont applicables pour la fabrication et la fourniture de l'appareil ou du système de protection. Ces dernières ne sont pas couvertes par la présente attestation.

12 Le marquage de l'appareil ou du système de protection doit comporter les informations détaillées au point 15.

Fontenay-aux-Roses, le 14 juin 2013

1 VOLUNTARY TYPE EXAMINATION CERTIFICATE

2 Equipment intended for use in potentially explosive atmospheres (Directive 94/9/EC)

3 Type Examination Certificate number **LCIE 13 ATEX 1010 X**

4 Equipment

Charge amplifier

Type : EX682XYYY

5 Applicant : PCB Piezotronics Inc.

Address : 3425 Walden Avenue

Depew, New York

14043 USA

7 This equipment or protective system and any acceptable variation thereto is specified in the schedule to this certificate and the documents therein referred to.

8 LCIE certifies that this equipment or protective system has been found to comply with the essential Health and Safety Requirements that relate to the design of equipment or protective system, of category 3 electrical or categories 2 and 3 non electrical, which is intended for use in potentially explosive atmospheres, given in Annex II of the Directive 94/9/EC of the European Parliament and Council of 23 March 1994.

The examination and test results are recorded in confidential report N°117214-634396.

9 Compliance with the Essential Health and Safety Requirements has been assured by reference to :

10 If the sign X is placed after the certificate number, it indicates that the equipment or protective system is subject to special conditions for safe use specified in the schedule to this certificate.

11 This type examination certificate relates only to the design, examination and tests of this specified equipment or protective system in accordance III to the directive 94/9/EC.

Further requirements of the Directive may apply to the manufacturing process and supply of this equipment or protective system. These are not covered by this certificate.

12 The marking of the equipment or protective system shall include informations as detailed at 15.



Seul le texte en français peut engager la responsabilité du LCIE. Ce document ne peut être reproduit que dans son intégralité, sans aucune modification.
The LCIE's liability applies only on the French text. This document may only be reproduced in its entirety and without any change

Page 1 sur 2
03-Annexe III_typ_app - rev3.DOC



L C I E

13 ANNEXE

14 ATTESTATION D'EXAMEN DE TYPE VOLONTAIRE

LCIE 13 ATEX 1010 X

15 DESCRIPTION DE L'APPAREIL OU DU SYSTEME DE PROTECTION

Amplificateur de charge
Type : EX682XYYY

L'amplificateur de charge fournit une tension de sortie à partir d'une charge d'entrée.

Définition du type :

X : désignation du type (A,B,...M)

YYY : filtrage, gain, réponse en fréquence,... (1 à 999)

Paramètres spécifiques du ou des modes de protection concernés :

Bornes d'alimentation (VDC, COM) :
 $U \leq 28V, I \leq 100mA, P \leq 0,7W$

Le marquage doit être :

PCB Piezotronics

Adresse : ...

Type : EX682XYYY (1)

Numéro de fabrication : ...

Année de construction : ...

Ex II 3 G

Ex nA IIC T4 Gc

LCIE 13 ATEX 1010 X

$-40^{\circ}C \leq T_{amb} \leq +85^{\circ}C$

(1)complété en fonction du modèle

L'appareil doit également comporter le marquage normalement prévu par les normes de construction qui le concerne.

16 DOCUMENTS DESCRIPTIFS

Dossier de certification N°54707 du 12/04/2013.
Ce dossier comprend 6 rubriques (10 pages).

17 CONDITIONS SPECIALES POUR UNE UTILISATION SÛRE

L'utilisateur doit se conformer aux prescriptions de la notice d'instruction.

Le composant doit être installé dans une enveloppe conforme aux exigences de la norme EN 60079-0 et ayant un degré de protection minimal IP54.

18 EXIGENCES ESSENTIELLES DE SECURITE ET DE SANTE

Couvertes par les normes listées au point 9.

19 VERIFICATIONS ET ESSAIS INDIVIDUELS

Néant.

13 SCHEDULE

14 VOLUNTARY TYPE EXAMINATION CERTIFICATE

LCIE 13 ATEX 1010 X

15 DESCRIPTION OF EQUIPMENT OR PROTECTIVE SYSTEM

Charge amplifier
Type : EX682XYYY

The charge amplifier provides a voltage output from a charge input.

Type definition :

X : family type (A,B,...M)

YYY : filtering, gain, frequency response,... (1 to 999)

Specific parameters of the concerned protection mode :

Power terminals (VDC, COM) :
 $U \leq 28V, I \leq 100mA, P \leq 0,7W$

The marking shall be :

PCB Piezotronics

Address : ...

Type : EX682XYYY (1)

Serial number : ...

Year of construction : ...

Ex II 3 G

Ex nA IIC T4 Gc

LCIE 13 ATEX 1010 X

$-40^{\circ}C \leq T_{amb} \leq +85^{\circ}C$

(1)completed according to the model

The equipment shall also bear the usual marking required by the manufacturing standards applying to such equipment.

16 DESCRIPTIVE DOCUMENTS

Certification file N°54707 dated 2013/04/12.
This file includes 6 items (10 pages).

17 SPECIAL CONDITIONS FOR SAFE USE

The user must comply with the requirements of the instructions for use.

The component shall be installed in an enclosure conform to requirements of standard EN 60079-0 and with ingress protection at least IP54.

18 ESSENTIAL HEALTH AND SAFETY REQUIREMENTS

Covered by standards listed at 9.

19 ROUTINE VERIFICATIONS AND TESTS

None.



СЕРТИФИКАТ СООТВЕТСТВИЯ

№ ЕАЭС RU C-US.AA87.B.00217/19



Серия **RU** № **0124866**

ОРГАН ПО СЕРТИФИКАЦИИ Орган по сертификации взрывозащищенного и рудничного оборудования (ОС ЦСВЭ) Общества с ограниченной ответственностью «Центр по сертификации взрывозащищенного и рудничного оборудования» (ООО «НАНИО ЦСВЭ»). Адрес места нахождения юридического лица: Россия, 140004, Московская область, Люберецкий район, город Люберцы, поселок ВУГИ, АО «Завод «ЭКОМАШ», литера В, Объект 6, этаж 3, офис 26. Адрес места осуществления деятельности в области аккредитации: Россия, 140004, Московская область, Люберецкий район, город Люберцы, поселок ВУГИ, АО «Завод «ЭКОМАШ», Литера В, Объект 6, этаж 3, офисы 26/3, 26/4, 26/5, 27/6, 30/1, 32. Аттестат № RA.RU.11AA87 от 20.07.2015 г. Телефон: +7 (495) 558-83-53, +7 (495) 558-82-44. Адрес электронной почты: ccve@ccve.ru

ЗАЯВИТЕЛЬ Общество с ограниченной ответственностью «Альфатех». Адрес места нахождения юридического лица: Россия, 125009, Москва, Малый Гнезниковский переулок, дом № 12, помещение I, комната 4. Адрес места осуществления деятельности: Россия, 127495, Москва, Долгопрудненское шоссе, дом № 3, Технопарк «Физтехпарк». ОГРН: 1167746393792. Телефон: +7 (495) 642-49-14. Адрес электронной почты: info@alphatechgroup.ru

ИЗГОТОВИТЕЛЬ PCB Piezotronics, Inc
Адрес места нахождения юридического лица и адрес места осуществления деятельности по изготовлению продукции: 3425 Walden Av., Depew, NY 14043, США

ПРОДУКЦИЯ Пьезоэлектрические преобразователи, вибропереключатели, предусилители с Ex-маркировкой согласно приложению (см. бланки №№ 0621345, 0621346, 0621347). Документы, в соответствии с которыми изготовлены изделия – см. приложение, бланк № 0621344. Серийный выпуск.

КОД ТН ВЭД ЕАЭС 9031 80 3800, 9026 20 2000, 8517 69 9000

СООТВЕТСТВУЕТ ТРЕБОВАНИЯМ
ТР ТС 012/2011 «О безопасности оборудования для работы во взрывоопасных средах».

СЕРТИФИКАТ СООТВЕТСТВИЯ ВЫДАН НА ОСНОВАНИИ
Протокола испытаний № 235.2019-Т от 11.09.2019 Испытательной лаборатории технических устройств Автономной некоммерческой организации «Национальный испытательный и научно-исследовательский институт оборудования для взрывоопасных сред» ИЛ Ex TU (аттестат № РОСС RU.0001.21MШ19 от 16.10.2015); Акта анализа состояния производства № 35-А/19 от 14.03.2019 Органа по сертификации взрывозащищенного и рудничного оборудования (ОС ЦСВЭ) Общества с ограниченной ответственностью «Центр по сертификации взрывозащищенного и рудничного оборудования» (ООО «НАНИО ЦСВЭ») (аттестат № RA.RU.11AA87 выдан 20.07.2015); Документов, представленных заявителем в качестве доказательства соответствия продукции требованиям ТР ТС 012/2011 (см. приложение, бланк № 0621344).
Схема сертификации – 1с.

ДОПОЛНИТЕЛЬНАЯ ИНФОРМАЦИЯ
Перечень стандартов, применяемых на добровольной основе для соблюдения требований ТР ТС 012/2011 (см. приложение, бланк № 0621344). Условия и срок хранения указаны в эксплуатационной документации. Назначенный срок службы – 10 лет.

СРОК ДЕЙСТВИЯ С 13.09.2019 ПО 12.09.2024
ВКЛЮЧИТЕЛЬНО

Руководитель (уполномоченное лицо) органа по сертификации

(подпись)

Залогин Александр Сергеевич

(Ф.И.О.)

Эксперт (эксперт-аудитор) (эксперты (эксперты-аудиторы))

(подпись)

М.П. Рафалович Борис Александрович

(Ф.И.О.)

ПРИЛОЖЕНИЕ

К СЕРТИФИКАТУ СООТВЕТСТВИЯ № БАЭС RU C-US.AA87.B.00217/19 Лист 1

Серия RU № 0621344

**I. ПЕРЕЧЕНЬ СТАНДАРТОВ, ПРИМЕНЯЕМЫХ НА ДОБРОВОЛЬНОЙ ОСНОВЕ
ДЛЯ СОБЛЮДЕНИЯ ТРЕБОВАНИЙ ТР ТС 012/2011 «О БЕЗОПАСНОСТИ ОБОРУДОВАНИЯ
ДЛЯ РАБОТЫ ВО ВЗРЫВООПАСНЫХ СРЕДАХ»**

Обозначение стандартов	Наименование стандартов
ГОСТ 31610.0-2014 (IEC 60079-0:2011)	Взрывоопасные среды. Часть 0. Оборудование. Общие требования
ГОСТ IEC 60079-1-2011	Взрывоопасные среды. Часть 1. Оборудование с видом взрывозащиты «взрывонепроницаемые оболочки «d»
ГОСТ 31610.11-2014 (IEC 60079-11:2011)	Взрывоопасные среды. Часть 11. Оборудование с видом взрывозащиты «искробезопасная электрическая цепь «i»
ГОСТ 31610.15-2012/МЭК 60079-15:2005	Электрооборудование для взрывоопасных газовых сред. Часть 15. Конструкция, испытания и маркировка электрооборудования с видом защиты «п»

**II. ДОКУМЕНТЫ, ПРЕДСТАВЛЕННЫЕ ЗАЯВИТЕЛЕМ В КАЧЕСТВЕ ДОКАЗАТЕЛЬСТВА
СООТВЕТСТВИЯ ПРОДУКЦИИ ТРЕБОВАНИЯМ ТР ТС 012/2011**

Руководства по эксплуатации: № 750119 от 23.01.19, № 830119 от 23.01.19, № 940219 от 07.02.19, № 630119 от 22.01.19, № 610119 от 22.01.19, № 910219 от 07.02.19, № 950219 от 08.02.19, № 970219 от 08.02.19.
Технические файлы: № 54202 от 02.02.2017, № 54204 от 02.02.2017, № 22438 С от 19.07.2012, № 62501 от 06.10.2016, № 33699 от 16.06.2016, № 56178 от 01.07.2016, № 70893 от 24.07.2019, № 54707 от 10.08.2016, № 48813 от 06.01.2011
Чертежи: № 47912 от 31.03.2017, № 49038 от 31.03.2017.
Перечень стандартов см. п. I.

III. ДОКУМЕНТЫ, В СООТВЕТСТВИИ С КОТОРЫМИ ИЗГОТОВЛЕНА ПРОДУКЦИЯ

Технические файлы: № 54202 от 02.02.2017, № 54204 от 02.02.2017, № 22438 С от 19.07.2012, № 62501 от 06.10.2016, № 33699 от 16.06.2016, № 56178 от 01.07.2016, № 70893 от 24.07.2019, № 54707 от 10.08.2016, № 48813 от 06.01.2011
Чертежи: № 47912 от 31.03.2017, № 49038 от 31.03.2017

Руководитель (уполномоченное
лицо) органа по сертификации

(подпись)

Эксперт (эксперт-аудитор)
(эксперты (эксперты-аудиторы))

(подпись)



Залогин Александр Сергеевич
(Ф.И.О.)

М.П.

Рафалович Борис Александрович
(Ф.И.О.)

ПРИЛОЖЕНИЕ

К СЕРТИФИКАТУ СООТВЕТСТВИЯ № ЕАЭС RU C-US.AA87.B.00217/19 Лист 2

Серия RU № 0621345

1. НАЗНАЧЕНИЕ И ОБЛАСТЬ ПРИМЕНЕНИЯ

Пьезоэлектрические преобразователи (далее – преобразователи) предназначены для контроля параметров вибрации, динамического давления и преобразования их в электрический сигнал.

Вибропереключатели предназначены для контроля уровня вибрации и защиты оборудования от повышенной вибрации.

Предусилители предназначены для преобразования зарядового сигнала в вольтовый.

Область применения - взрывоопасные зоны помещений и наружных установок согласно Ex-маркировке, ГОСТ IEC 60079-14-2013, регламентирующих применение во взрывоопасных средах.

2. СТРУКТУРНОЕ ОБОЗНАЧЕНИЕ

2.1. Преобразователи 176ХУУ/МZZZ-АА

X = от А до Z ревизия продукта, не влияющая на взрывозащиту

УУ = от 01 до 99 для индикации вариантов монтажа, диафрагмы, кабелей или разъемов

M = опционально для указания метрической длины кабеля

ZZZ = от 001 до 999 опционально для указания длины кабеля в футах: (не более 200 футов) или метрах: (не более 61 м)

AA = от 01 до 99 опционально для указания дробной длины кабеля в дюймах или сантиметрах, не влияющей на взрывозащиту

2.2. Преобразователи 351abcd

a – ревизия продукта, может быть: А,В,С,Д,Е,Ф,Г,Н,І,Ј,К,Л или М, не влияющая на взрывозащиту

b – первая цифра вариации продукта, может быть: 0,1,2,3,4,5,6,7,8 или 9, не влияющая на взрывозащиту

c – вторая цифра вариации продукта, может быть: 0,1,2,3,4,5,6,7,8 или 9, не влияющая на взрывозащиту

d – третья цифра вариации продукта, может быть: 0,1,2,3,4,5,6,7,8,9 или отсутствует, не влияющая на взрывозащиту

2.3 Преобразователи EX(TO)(M)602yzzz1aaa, EX(TO)(M)603yzzz/aaa, EX(TO)(M)606yzzz/aaa, EX(TO)(M)607yzzz/aaa, EX(TO)(M)608yzzz/aaa, EX(M)637XYYYZ, (M)638XYYYZ

XX = TO (с температурным выходом), M (с метрической резьбой),

y = одна буква от А до Z, не влияющая на взрывозащиту

zzz = две или три цифры от 00 до 999, не влияющие на взрывозащиту

aaa = длина кабеля и/или тип разъема

2.4 Предусилители EX682XYYY

X – ревизия продукта (А,В ... М), не влияющая на взрывозащиту

YYY: параметры фильтрации, усиления, частотная характеристика, ... (от 1 до 999), не влияющие на взрывозащиту

2.5 Преобразователи EX(RV)(TO)(M)64хухх, EX(RV)(TO)(M)649ухх, EX (RV)(TO) (M)686ухх

XX = M (с метрической резьбой), TO (с температурным выходом), RV (с доп. вольтовым выходом).

Буквы х являются переменными цифрами (значения от 0 до 9), не влияющими на взрывозащиту

y = одна буква от А до Z, не влияющая на взрывозащиту

2.6 Преобразователи EX (XX) 622yzzz / aaa, EX (XX) 623yzzz / aaa, EX (XX) 625yzzz / aaa, EX (XX) 628yzzz / aaa

XX = HT (Высокотемпературная версия), M (с метрической резьбой), TO (с температурным выходом), VO (с выходом по скорости).

y = одна буква от А до Z, не влияющая на взрывозащиту

zzz = две или три цифры от 00 до 999, не влияющие на взрывозащиту

aaa = длина кабеля и/или тип разъема

2.7 Вибропереключатели 685ухх

Буквы х являются переменными цифрами (значения от 0 до 9), не влияющими на взрывозащиту

y = одна буква от А до Z, не влияющая на взрывозащиту

Руководитель (уполномоченное
лицо) органа по сертификации

(подпись)

Залогин Александр Сергеевич
(Ф.И.О.)

Эксперт (эксперт-аудитор)
(эксперты (эксперты-аудиторы))

(подпись)

Рафалович Борис Александрович
(Ф.И.О.)

ПРИЛОЖЕНИЕ

К СЕРТИФИКАТУ СООТВЕТСТВИЯ № ЕАЭС RU C-US.AA87.B.00217/19 Лист 3

Серия **RU** № **0621346**

3. ОСНОВНЫЕ ТЕХНИЧЕСКИЕ ДАННЫЕ

3.1. Ех-маркировка: преобразователей 176XYU/MZZ-AA	0Ex ia IIC T660°C...T6 Ga X
преобразователей 351abcd	0Ex ia IIC T4 Ga X
вибропереключателей 685yxx	1Ex d IIB+H ₂ T4 Gb
преобразователей EX(TO)(M)602yzzz1aaa, EX(TO)(M)603yzzz/aaa, EX(TO)(M)606yzzz/aaa, EX(TO)(M)607yzzz/aaa, EX(TO)(M)608yzzz/aaa	2Ex nA IIC T4 Gc X или 0Ex ia IIC T4 Ga X
преобразователей EX(M)637XYUZZ, (M)638XYUZZ	0Ex ia IIC T4 Ga X или 2Ex nA IIC T4 Gc X
предусилителей EX682XYU	0Ex ia IIC T4 Ga X или 2Ex nA IIC T4 Gc X
EX(RV)(TO)(M)64хухх, EX(RV)(TO)(M)649ухх, EX (RV)(TO) (M)686ухх	1Ex d IIC T4 Gb X или 1Ex d IIC T3 Gb X
преобразователей EX (XX) 622yzzz / aaa, EX (XX) 623yzzz / aaa, EX (XX) 625yzzz / aaa , EX (XX) 628yzzz / aaa	2Ex nA IIC T4 Gc X
3.2. Диапазон температур окружающей среды, °С, преобразователей 176XYU/MZZ-AA	от -70 до 650
преобразователей 351abcd	от -196 до 121
вибропереключателей 685yxx	от -25 до 60
преобразователей EX(TO)(M)602yzzz1aaa, EX(TO)(M)603yzzz/aaa, EX(TO)(M)606yzzz/aaa, EX(TO)(M)607yzzz/aaa, EX(TO)(M)608yzzz/aaa	от -54 до 121
преобразователей EX(M)637XYUZZ, (M)638XYUZZ	от -196 до 121
предусилителей EX682XYU	от -40 до 85
преобразователей EX(RV)(TO)(M)64хухх, EX(RV)(TO)(M)649ухх, EX (RV)(TO) (M)686ухх	от -20 до 80
преобразователей EX (XX) 622yzzz / aaa, EX (XX) 623yzzz / aaa, EX (XX) 625yzzz / aaa , EX (XX) 628yzzz / aaa	от -54 до 121

3.3. Входные искробезопасные электрические параметры преобразователей, предусилителей:

Модель	U _i , В	I _i , мА	P _i , Вт	C _i , нФ	L _i , мГн
преобразователей 176XYU/MZZ-AA	30	300	1	5	0,5
преобразователей 351abcd	28	200	1,2	61	305 мкГн
преобразователей EX(TO)(M)602yzzz1aaa, EX(TO)(M)603yzzz/aaa, EX(TO)(M)606yzzz/aaa, EX(TO)(M)607yzzz/aaa, EX(TO)(M)608yzzz/aaa	28	200	1	16,2 или 77,2 (с кабелем)	пренебрежимо мала или 305 мкГн (с учетом кабеля 305м)
преобразователей EX(M)637XYUZZ, (M)638XYUZZ	28	93	0,65	6,5	пренебрежимо мала
предусилителей EX682XYU	28	100	0,7	пренебрежимо мала	пренебрежимо мала

Руководитель (уполномоченное
лицо) органа по сертификации

(подпись)

Эксперт (эксперт-аудитор)
(эксперты (эксперты-аудиторы))

(подпись)

Залогин Александр Сергеевич

(Ф.И.О.)

М.П. Рафалович Борис Александрович

(Ф.И.О.)

ПРИЛОЖЕНИЕ

К СЕРТИФИКАТУ СООТВЕТСТВИЯ № ЕАЭС RU C-US.AA87.B.00217/19 Лист 4

Серия **RU** № **0621347**

3.4. Электрические параметры:

3.4.1 вибропереключателей 685ухх

Напряжение питания, В 85-245 (AC), 24 (DC)
 Максимальный ток, mA 150

3.4.2 преобразователей EX(TO)(M)602yzzz/aaa, EX(TO)(M)603yzzz/aaa, EX(TO)(M)606yzzz/aaa, EX(TO)(M)607yzzz/aaa, EX(TO)(M)608yzzz/aaa, EX (XX) 622yzzz / aaa, EX (XX) 623yzzz / aaa, EX (XX) 625yzzz / aaa, EX (XX) 628yzzz / aaa

с Ex-маркировкой 2Ex nA IIC T4 Gc X:

Напряжение питания, В 28
 Максимальный ток, mA 200
 Мощность, Вт 1

3.4.3 преобразователей EX(M)637XYYYZ, (M)638XYYYZ

Напряжение питания, В 18 – 28
 Максимальный ток, mA 1,6 – 20
 Мощность, Вт 0,5

3.4.4 Предусилителей EX682XYYY

Напряжение питания, В 22 – 28
 Максимальный ток, mA 3,1 – 4,1
 Мощность, Вт 0,1

3.4.5 преобразователей EX(RV)(TO)(M)64уххх, EX(RV)(TO)(M)649уххх, EX (RV)(TO) (M)686ухх

Напряжение питания, В 18 – 30
 Максимальный ток, mA 1,6 – 20
 Мощность, Вт 0,5

4. ОПИСАНИЕ КОНСТРУКЦИИ И СРЕДСТВ ОБЕСПЕЧЕНИЯ ВЗРЫВОЗАЩИЩЕННОСТИ

Преобразователи состоят из герметичного цилиндрического металлического корпуса, в котором размещается печатная плата и пьезокристаллический элемент. Сборка подключается к разъему или встроенному кабелю. На наружной поверхности корпуса преобразователя нанесена маркировка.

Вибропереключатели серии 685ухх выполнены в металлическом корпусе, внутри которого размещена электронная плата. На наружной поверхности корпуса нанесена маркировка.

Предусилители серии EX682XYYY выполнены в прямоугольном пластиковом корпусе с креплением на DIN рейку. Внутри корпуса размещена электронная плата. На корпусе размещен съемный клеммный блок. На наружной поверхности корпуса нанесена маркировка.

Подробное описание конструкции приведено в Руководствах по эксплуатации №750119 от 23.01.19, №830119 от 23.01.19, №940219 от 07.02.19, №630119 от 22.01.19, №610119 от 22.01.19, №910219 от 07.02.19, №950219 от 08.02.19, №970219 от 08.02.19

Взрывозащищенность преобразователей, вибропереключателей и предусилителей обеспечивается выполнением требований: ГОСТ 31610.15-2012/МЭК 60079-15:2005, ГОСТ 31610.0-2014 (IEC 60079-0:2011), ГОСТ IEC 60079-1-2011, ГОСТ 31610.11-2014 (IEC 60079-11:2011), в соответствии с Ex-маркировкой.

5. МАРКИРОВКА

Маркировка, наносимая на преобразователи, вибропереключатели и предусилители, включает следующие данные:

- товарный знак или наименование предприятия-изготовителя;
- серийный номер или номер партии;
- диапазон значений температур окружающей среды при эксплуатации;
- Ex-маркировку;
- специальный знак взрывобезопасности;
- наименование центра по сертификации и номер сертификата;
- предупредительные надписи;
- искробезопасные параметры

и другие данные, которые изготовитель должен отразить в маркировке, в соответствии с требованиями нормативной и технической документации.

6. СПЕЦИАЛЬНЫЕ УСЛОВИЯ ПРИМЕНЕНИЯ

5.1 Знак X, стоящий после Ex-маркировки, означает, что при эксплуатации преобразователей, вибропереключателей, предусилителей необходимо соблюдать следующие специальные условия:

- преобразователи, вибропереключатели, предусилители должны быть подключены к сертифицированному на соответствие требованиям ТР ТС 012/2011 источнику питания с соответствующей областью применения.

5.2 Свободные концы постоянно подсоединенного кабеля должны подключаться в сертифицированной на соответствие требованиям ТР ТС 012/2011 соединительной коробке или вне взрывоопасной зоны.

Специальные условия применения, обозначенные знаком X, отражены в сопроводительной документации, подлежащей обязательной поставке в комплекте с каждым изделием.

Внесение изменений в конструкцию изделий возможно только по согласованию с ОС ЦСВЭ в соответствии с требованиями ТР ТС 012/2011.

Руководитель (уполномоченное лицо) органа по сертификации

Эксперт (эксперт-аудитор) (эксперты (эксперты-аудиторы))

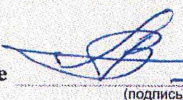
(подпись)

(подпись)

(подпись)



Залогин Александр Сергеевич

(ф.и.о.)

М.П. Рафалович Борис Александрович

(ф.и.о.)

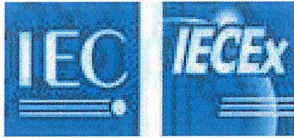

IECEx Certificate of Conformity

INTERNATIONAL ELECTROTECHNICAL COMMISSION IEC Certification Scheme for Explosive Atmospheres

for rules and details of the IECEx Scheme visit www.iecex.com

Certificate No.: IECEx LCIE 13.0002X Issue No: 2 Certificate history:
Issue No. 2 (2016-09-30)
Status: **Current** Page 1 of 4 Issue No. 1 (2015-11-09)
Issue No. 0 (2013-06-17)
Date of Issue: **2016-09-30**
Applicant: **PCB Piezotronics Inc.**
3425 Walden Avenue
Depew, New York 14043
United States of America
Equipment: **Charge amplifier - Type EX682XXXX**
Optional accessory:
Type of Protection: **Ex ia, Ex nA**
Marking:
Ex ia IIC T4 Ga
Ex nA IIC T4 Gc

Approved for issue on behalf of the IECEx
Certification Body:

Julien GAUTHIER

Position:

Certification Officer

Signature:
(for printed version)

Date:



1. This certificate and schedule may only be reproduced in full.
2. This certificate is not transferable and remains the property of the issuing body.
3. The Status and authenticity of this certificate may be verified by visiting the [Official IECEx Website](http://www.iecex.com).

Certificate issued by:

Laboratoire Central des Industries Electriques (LCIE)
33 Avenue du General Leclerc
FR-92260 Fontenay-aux-Roses
France



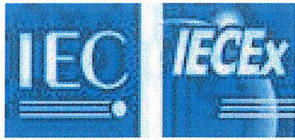

IECEX Certificate of Conformity

Certificate No: IECEx LCIE 13.0002X

Issue No: 2

Date of Issue: **2016-09-30**

Page 2 of 4

Manufacturer: **PCB Piezotronics**
3425 Walden Avenue
Depew, New York 14043
United States of America

Additional Manufacturing location(s):
PCB Piezotronics of North Carolina Inc.
10869 Hwy 903
Halifax, NC 27839
United States of America

This certificate is issued as verification that a sample(s), representative of production, was assessed and tested and found to comply with the IEC Standard list below and that the manufacturer's quality system, relating to the Ex products covered by this certificate, was assessed and found to comply with the IECEx Quality system requirements. This certificate is granted subject to the conditions as set out in IECEx Scheme Rules, IECEx 02 and Operational Documents as amended.

STANDARDS:

The electrical apparatus and any acceptable variations to it specified in the schedule of this certificate and the identified documents, was found to comply with the following standards:

IEC 60079-0 : 2011 Edition:6.0	Explosive atmospheres - Part 0: General requirements
IEC 60079-11 : 2011 Edition:6.0	Explosive atmospheres - Part 11: Equipment protection by intrinsic safety "i"
IEC 60079-15 : 2010 Edition:4	Explosive atmospheres - Part 15: Equipment protection by type of protection "n"

*This Certificate **does not** indicate compliance with electrical safety and performance requirements other than those expressly included in the Standards listed above.*

TEST & ASSESSMENT REPORTS:

A sample(s) of the equipment listed has successfully met the examination and test requirements as recorded in

Test Report:

FR/LCIE/ExTR13.0001/00

FR/LCIE/ExTR15.0109/00

FR/LCIE/ExTR16.0055/00

Quality Assessment Report:

NL/DEK/QAR14.0004/01

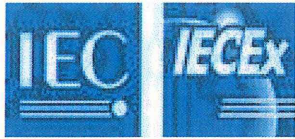

IECEX Certificate of Conformity

Certificate No: IECEx LCIE 13.0002X

Issue No: 2

Date of Issue: 2016-09-30

Page 3 of 4

Schedule

EQUIPMENT:

Equipment and systems covered by this certificate are as follows:

The charge amplifier provides a voltage output from a charge input.

Type definition :EX682XYYY

X : it is a letter that signifies family type (A,B,...M)

YYY : it is a number that signifies changes to filtering, gain, frequency response, ... (1 to 999)

Electrical parameters for Ex ia protection :

Power terminals (VDC,COM) : U_i : 28V, I_i : 100mA, P_i : 0.7W, $C_i = 0$, $L_i = 0$

Sensor terminals (-SIG, +SIG, SHLD) : U_o : 28V, I_o : 60mA, P_o : 0.42W, C_o : 83nF, L_o : 10mH

Input parameters for Ex nA protection :

$U \leq 28V$, $I \leq 100mA$, $P \leq 0.7W$

Instructions : 62771 Rev A

Marking:

PCB Piezotronics Inc.

Address :...

Type : EX682XYYY (completed with the model)

Serial number :....

Year of construction : ...

Ex ia IIC T4 Ga or Ex nA IIC T4 Gc

IECEX LCIE 13.0002 X

$U_i, I_i, P_i, C_i, L_i, U_o, I_o, P_o, C_o, L_o$ (1)

(1) Completed with the electrical parameters, only for Ex ia protection

CONDITIONS OF CERTIFICATION: YES as shown below:

Version Ex ia :

The equipment can be only connected to intrinsically safe certified equipment or simple apparatus. These combinations must be compatible as regard the intrinsic safety rules (see electrical parameters).

Version Ex nA :

The component shall be installed in an enclosure conform to requirements of standard IEC 60079-0 and with ingress protection at least IP54.

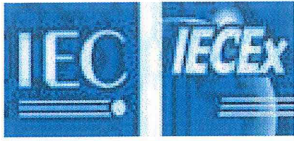

IECEX Certificate of Conformity

Certificate No: IECEX LCIE 13.0002X

Issue No: 2

Date of Issue: 2016-09-30

Page 4 of 4

DETAILS OF CERTIFICATE CHANGES (for issues 1 and above):

Issue 00 (2013-6-17):

initial assessment

Issue 01 (2015-11-9):

Modification of QAR

Addition of a manufacturing site

Issue 02 :

Addition of a new model by modifying an existing model.

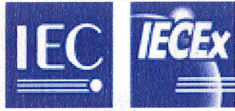

IECEX Certificate of Conformity

INTERNATIONAL ELECTROTECHNICAL COMMISSION
IEC Certification Scheme for Explosive Atmospheres
for rules and details of the IECEx Scheme visit www.iecex.com

Certificate No.: **IECEX LCIE 13.0002X** issue No.:1
Status: **Current**
Date of Issue: **2015-11-09** Page 1 of 4

Certificate history:
Issue No. 1 (2015-11-9)
Issue No. 0 (2013-6-17)

Applicant: **PCB Piezotronics**
3425 Walden Avenue
Depew, New York 14043
United States of America

Electrical Apparatus: **Charge amplifiers**
Optional accessory: **Type EX682M57**

Type of Protection: **Ex ia, Ex nA**

Marking: **PCB Piezotronics**
Address :...
Type : EX682XYYY (completed with the model)
Serial number :....
Year of construction : ...
Ex ia IIC T4 Ga or Ex nA IIC T4 Gc
IECEX LCIE 13.0002 X
Ui, li, Pi, Ci, Li, Uo, lo, Po, Co, Lo (1)
(1) completed with the electrical parameters, only for Ex ia protection

Approved for issue on behalf of the IECEx
Certification Body:

Julien GAUTHIER

Position:

Certification Officer

Signature:
(for printed version)

Date:

2015-11-09

1. This certificate and schedule may only be reproduced in full.
2. This certificate is not transferable and remains the property of the issuing body.
3. The Status and authenticity of this certificate may be verified by visiting the [Official IECEx Website](http://www.iecex.com).

Certificate issued by:
Laboratoire Central des Industries Electriques (LCIE)
33 Avenue du General Leclerc
FR-92260 Fontenay-aux-Roses
France

Documents relative to LCIE certification activities (Certificates, QARs, ExTRs) can be registered under the references "LCI" or "LCIE".





IECEx Certificate of Conformity

Certificate No.: IECEx LCIE 13.0002X

Date of Issue: 2015-11-09

Issue No.: 1

Page 2 of 4

Manufacturer: **PCB Piezotronics**
3425 Walden Avenue
Depew, New York 14043
United States of America

Additional Manufacturing location
(s):

**PCB Piezotronics of
North Carolina Inc.**
10869 Hwy 903
Halifax, NC 27839
United States of America

This certificate is issued as verification that a sample(s), representative of production, was assessed and tested and found to comply with the IEC Standard list below and that the manufacturer's quality system, relating to the Ex products covered by this certificate, was assessed and found to comply with the IECEx Quality system requirements. This certificate is granted subject to the conditions as set out in IECEx Scheme Rules, IECEx 02 and Operational Documents as amended.

STANDARDS:

The electrical apparatus and any acceptable variations to it specified in the schedule of this certificate and the identified documents, was found to comply with the following standards:

IEC 60079-0 : 2011 Edition: 6.0	Explosive atmospheres - Part 0: General requirements
IEC 60079-11 : 2011 Edition: 6.0	Explosive atmospheres - Part 11: Equipment protection by intrinsic safety "i"
IEC 60079-15 : 2010 Edition: 4	Explosive atmospheres - Part 15: Equipment protection by type of protection "n"

*This Certificate **does not** indicate compliance with electrical safety and performance requirements other than those expressly included in the Standards listed above.*

TEST & ASSESSMENT REPORTS:

A sample(s) of the equipment listed has successfully met the examination and test requirements as recorded in

Test Report:
FR/LCIE/ExTR13.0001/00

FR/LCIE/ExTR15.0109/00

Quality Assessment Report:

NL/DEK/QAR14.0004/01

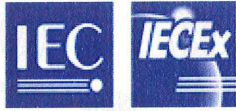

IECEx Certificate of Conformity

Certificate No.: IECEx LCIE 13.0002X

Date of Issue: 2015-11-09

Issue No.: 1

Page 3 of 4

Schedule

EQUIPMENT:

Equipment and systems covered by this certificate are as follows:

The charge amplifier provides a voltage output from a charge input.

Type definition :EX682XXXX

X : it is a letter that signifies family type (A,B,...M)

YYY : it is a number that signifies changes to filtering, gain, frequency response, ... (1 to 999)

Electrical parameters for Ex ia protection :

Power terminals (VDC,Com) : $U_i \leq 28V$, $I_i \leq 100mA$, $P_i \leq 0,7W$, $C_i = 0$, $L_i = 0$

Sensor terminals (-SIG, +SIG, SHLD) : $U_o \leq 28V$, $I_o \leq 60mA$, $P_o \leq 0,42W$, $C_o \leq 83nF$, $L \leq 10mH$

Input parameters for Ex nA protection :

$U \leq 28V$, $I \leq 100mA$, $P \leq 0,7W$

CONDITIONS OF CERTIFICATION: YES as shown below:

Version Ex ia :

The equipment can be only connected to intrinsically safe certified equipment. These combinations must be compatible as regard the intrinsic safety rules (see electrical parameters).

Version Ex nA :

The user must comply with the requirements of the instructions for use.

The component shall be installed in an enclosure conform to requirements of standard IEC 60079-0 and with ingress protection at least IP54.



IECEx Certificate of Conformity

Certificate No.: IECEx LCIE 13.0002X

Date of Issue: 2015-11-09

Issue No.: 1

Page 4 of 4

DETAILS OF CERTIFICATE CHANGES (for issues 1 and above):

Issue 01 :
Modification of QAR
Addition of a manufacturing site



IECEX Certificate of Conformity

INTERNATIONAL ELECTROTECHNICAL COMMISSION IEC Certification Scheme for Explosive Atmospheres

for rules and details of the IECEx Scheme visit www.iecex.com

Certificate No.: issue No.: Certificate history:

Status:

Date of Issue: **2013-06-17** Page 1 of 3

Applicant: **PCB Piezotronics Inc.**
3425 Walden Avenue
Depew, New York 14043
United States of America

Electrical Apparatus: **Charge amplifiers type EX682M57**
Optional accessory:

Type of Protection: **ia and nA**

Marking: PCB Piezotronics Inc. Address :...
Type EX682XYYY (completed with the model)
Serial number :.... Year of construction : ...
Ex ia IIC T4 Ga or Ex nA IIC T4 Gc
IECEX LCIE 13.0002 X
Ui, li, Pi, Ci, Li, Uo, lo, Po, Co, Lo (1)
(1) completed with the electrical parameters, only for Ex ia protection

Approved for issue on behalf of the IECEx
Certification Body:

Julien GAUTHIER

Position:

Certification Officer

Signature:
(for printed version)

Date:

2013-06-14

1. This certificate and schedule may only be reproduced in full.
2. This certificate is not transferable and remains the property of the issuing body.
3. The Status and authenticity of this certificate may be verified by visiting the [Official IECEx Website](http://www.iecex.com).

Certificate issued by:

Laboratoire Central des Industries Electriques (LCIE)
33 Avenue du General Leclerc
FR-92260 Fontenay-aux-Roses
France

Documents relative to LCIE certification activities (Certificates,
QARs, ExTRs) can be registered under the references "LCI" or
"LCIE".



L C I E



IECEX Certificate of Conformity

Certificate No.: IECEx LCIE 13.0002X

Date of Issue: 2013-06-17

Issue No.: 0

Page 2 of 3

Manufacturer: **PCB Piezotronics Inc.**
3425 Walden Avenue
Depew, New York 14043
United States of America

Additional Manufacturing location
(s):

This certificate is issued as verification that a sample(s), representative of production, was assessed and tested and found to comply with the IEC Standard list below and that the manufacturer's quality system, relating to the Ex products covered by this certificate, was assessed and found to comply with the IECEx Quality system requirements. This certificate is granted subject to the conditions as set out in IECEx Scheme Rules, IECEx 02 and Operational Documents as amended.

STANDARDS:

The electrical apparatus and any acceptable variations to it specified in the schedule of this certificate and the identified documents, was found to comply with the following standards:

IEC 60079-0 : 2011 Edition: 6.0	Explosive atmospheres - Part 0: General requirements
IEC 60079-11 : 2011 Edition: 6.0	Explosive atmospheres - Part 11: Equipment protection by intrinsic safety "i"
IEC 60079-15 : 2010 Edition: 4	Explosive atmospheres - Part 15: Equipment protection by type of protection "n"

*This Certificate **does not** indicate compliance with electrical safety and performance requirements other than those expressly included in the Standards listed above.*

TEST & ASSESSMENT REPORTS:

A sample(s) of the equipment listed has successfully met the examination and test requirements as recorded in

Test Report:

FR/LCIE/ExTR13.0001/00

Quality Assessment Report:

CA/CSA/QAR09.0018/00

CA/CSA/QAR09.0018/01

CA/CSA/QAR09.0018/02



IECEx Certificate of Conformity

Certificate No.: IECEx LCIE 13.0002X

Date of Issue: 2013-06-17

Issue No.: 0

Page 3 of 3

Schedule

EQUIPMENT:

Equipment and systems covered by this certificate are as follows:

The charge amplifier provides a voltage output from a charge input.

Type definition :EX682XYYY

X : it is a letter that signifies family type (A,B,...M)

YYY : it is a number that signifies changes to filtering, gain, frequency response, ... (1 to 999)

Electrical parameters for Ex ia protection :

Power terminals (VDC,COm) : $U_i \leq 28V$, $I_i \leq 100mA$, $P_i \leq 0,7W$, $C_i = 0$, $L_i = 0$

Sensor terminals (-SIG, +SIG, SHLD) : $U_o \leq 28V$, $I_o \leq 60mA$, $P_o \leq 0,42W$, $C_o \leq 83nF$, $L \leq 10mH$

Input parameters for Ex nA protection :

$U \leq 28V$, $I \leq 100mA$, $P \leq 0,7W$

CONDITIONS OF CERTIFICATION: YES as shown below:

Version Ex ia :

The equipment can be only connected to intrinsically safe certified equipment. These combinations must be compatible as regard the intrinsic safety rules (see electrical parameters)

Version Ex nA :

The user must comply with the requirements of the instructions for use.

The component shall be installed in an enclosure conform to requirements of standard IEC 60079-0 and with ingress protection at least IP54.



제2020-000699-01-1호

안전인증서

PCB Piezotronics Inc.

3425 Walden Avenue, Depew, New York 14043, USA

위 사업장에서 제조하는 아래의 품목이 「산업안전보건법」 제34조 및 같은 법 시행규칙 제58조의4제4항에 따른 안전인증 심사 결과 안전·보건기준에 적합하므로 안전인증표시의 사용을 인증합니다.

품 목

Charge Amplifier

형식·모델(용량·등급) / 인증번호

EX682**(Ex ia IIC T4) / 19-KA4BO-0467X

인증기준

고용노동부고시 제2019-15호

인증조건

1. 제조공장

·본 인증서는 '3425 Walden Avenue, Depew, New York 14043, USA'에서 생산하는 제품에 한함.

2. 제품개요

·당 기기는 차동 출력 충전 센서와 인터페이스하도록 설계된 본질안전 방폭구조의 차동 충전 입력 증폭기임.

·본질안전을 위한 전기적 파라미터

Power terminals (VDC, COM)
$U_i = 28 \text{ V}, I_i = 100 \text{ mA}, P_i = 0.7 \text{ W}, C_i = 0, L_i = 0$
Sensor terminals (-SIG, +SIG, SHLD)
$U_o = 28 \text{ V}, I_o = 60 \text{ mA}, P_o = 0.42 \text{ W}, C_o = 83 \text{ nF}, L_o = 10 \text{ mH}$

·사용주위온도: $-40 \text{ }^\circ\text{C} \leq T_a \leq +85 \text{ }^\circ\text{C}$

3. 인증범위: 본 인증서는 아래의 형식번호에 한하여 유효함

·EX682(a)(b)

-(a): A~M, (b): 1~999

4. 안전한 사용을 위한 조건

·관련 IECEx 인증서(IECEx LCIE 13.0002X issue No.2) 3페이지 CONDITIONS OF CERTIFICATION 참조

5. 인증(변경)사항

·1차 변경(2020.01.10.): 기존 제2019-030152-01-1호에서 동일형식 추가에 따른 변경

6. 그 밖의 사항

·사용자 설명서 참조

·안전인증품의 품질관리, 확인심사 수검, 변경사항 신고 등 인증 받은 자의 의무 준수

·본 안전인증서는 반드시 관련 IECEx 인증서(IECEx LCIE 13.0002X issue No.2)와 함께 사용

2019년 7월 3일

한국산업기술시험원장



안전인증을 받은 자의 유의사항 [Notification for recipient (certification holder)]

1. 본 인증서는 기재된 사업장에서 생산된 제품으로서 적용된 안전인증기준에 적합한 경우에 한하여 유효합니다. (This certificate is valid only when the product is suitable for the applied safety certification criteria and is manufactured from the manufacturing location that is stipulated on this certificate)
2. 안전인증을 받은 자가 다음 각 호의 어느 하나에 해당하면 인증정지 및 취소의 사유가 됩니다. (If a person who has received safety certification falls under any of the following subclause, this safety certification may be suspended or cancelled)
 - 1) 거짓이나 그 밖의 부정한 방법으로 안전인증을 받은 경우 (In case of being certified in false or other improper ways)
 - 2) 안전인증을 받은 안전인증대상 기계기구등의 안전에 관한 성능 등이 안전인증기준에 맞지 아니하게 된 경우 (In the case that the properties of the product for which safety certification has been received are not suitable for the safety certification criteria)
 - 3) 정당한 사유 없이 확인심사를 거부, 기피 또는 방해하는 경우 (In case of refusing, avoiding or disturbing regular surveillance audit without a justifiable reason)
3. 다음과 같은 사유가 발생할 경우에는 안전인증기관에 안전인증 변경 신청을 하여 안전인증서를 재교부 받아야 합니다. (In the case of the following subclauses, the revision of the safety certification shall be applied to the safety certification body and the safety certificate shall be reissued)
 - 1) 인증서의 분실 또는 훼손 (Losses or damages to this certificate)
 - 2) 제조자, 주소, 인증조건 등 인증서 기재사항의 변경 (Changes of stated items in the certificate such as manufacturer's name, manufacturer's address, certification conditions, etc)
4. 안전인증을 받은 자는 다음 사항을 이행해야 합니다. (The recipient of safety certificate (certification holder) shall comply with the following subclauses)
 - 1) 안전인증표시 등 인증요건의 유지관리 (Maintenance control of the certification requirements such as a safety certification mark)
 - 2) 안전인증을 받기 이전 또는 정지, 취소된 이후 생산된 제품에 안전인증표시를 하면 법에 의거 처벌을 받게 됩니다. (It will be punished by the ACT if the safety certification mark is used before issue of the safety certification or after suspension or cancellation of the safety certification)
5. 안전인증을 받은 자는 산업안전보건법 제34조 5항 및 동법 시행규칙 제58조의5에 따라 정기적인 확인심사를 받아야 합니다. (The recipient of the safety certification (certification holder) shall receive a regular surveillance audit under Paragraph 5 of Article 34 of OCCUPATIONAL SAFETY AND HEALTH ACT and Article 58-5 of ENFORCEMENT ORDINANCE in the same ACT)

연락처(Contact information) : 서울 사무소(Seoul office) Tel +82-2-860-1540, Fax +82-2-860-1549
E-mail: kang@ktl.re.kr, Homepage: www.ktl.re.kr



EU Declaration of Conformity PS123
In Accordance with ISO/IEC 17050

Manufacturer: PCB Piezotronics, Inc. 3425 Walden Avenue Depew, New York 14043 USA	Authorized European Representative: PCB Piezotronics Europe GmbH Porschestrasse 20-30 41836 Hückelhoven, Germany
--	---

Certifies that type of equipment: Differential Charge Amplifier
Whose Product Models Include: EX682XXXX
 X: it is a letter that signifies family type (A, B,...M)
 Y: it is a number that signifies changes to filtering, gain, frequency response, (1 to 999).

This declaration is applicable to the EX682 series Differential Charge Amplifier which have the CE mark on their data sheets and where those data sheets refer to this declaration of conformity. The data sheets for all model numbers referenced above which include the CE mark on such data sheets and refer to this Declaration of Conformity are hereby incorporated by reference into this Declaration.

Conform to the following EU Directive(s) when installed per product documentation:	2014/30/EU 2014/34/EU 2011/65/EU	EMC Directive Explosive Atmospheres Directive RoHS Directive
---	--	--

Standards to which Conformity is Declared:

Harmonized Standards	EN 61326-1:2013 EN 61326-2-3: 2013 EN 61010-1:2010 EN 60079-0 :2012+ A11:2013 EN 60079-11 2012 EN 50581:2012	Electrical Equipment for Measurement, Control and Laboratory Use-EMC Electrical Equipment for Measurement, Control and Laboratory Use-EMC Safety and EMC requirements for electrical equipment in a laboratory setting. General Explosive Atmosphere Intrinsic safe, i Technical documentation for the assessment of electrical and electronic products with respect to the restriction of hazardous substances
Emissions Test Standards	EN 55011:2009+ A1:2010	Industrial, scientific and medical (ISM) radio frequency equipment- Electromagnetic disturbance characteristics- Limits and methods of Measurement Class B
Other Standards Applied (non-OJEU) Immunity Test Standards	EN 61000-4-2:2001 EN 61000-4-3:2006 EN 61000-4-4:2004 EN 61000-4-5:2005 EN 61000-4-6:2006 EN 61000-4-8:2001	Electrostatic discharge (ESD) Radiated, radio-frequency, electromagnetic field immunity Electrical fast transient (EFT) / Burst immunity Surge immunity Immunity to RF conducted line disturbances Power frequency magnetic field immunity
Test Reports	EMC Reports Safety Reports	GM213057c GM213058s
EC Type Examination	ATEX Certification	LCIE 13 ATEX 3031X Ex ia IIC T4 Ga, II 1 G
Voluntary Certification	Voluntary Type Examination Certificate	LCIE 13 ATEX 1010 X Ex nA IIC T4 Gc, II 3 G
Other International Certifications	IECEx Certification	LCIE 13.0002x Ex ia IIC T4 Ga or Ex nA IIC T4 Gc

Notified Body Name		Laboratoire Central des Industries Electriques (0081)
Notified Body's Address		FONTENAY-AUX-ROSES (Head Office) 33, avenue du Général Leclerc FR- 92260 Fontenay-aux-Roses Tel. : + 33 1 40 95 60 60 Fax : + 33 1 40 95 86 56

I, the undersigned, hereby declare that the equipment specified above conforms to the above Directive(s) Standard(s)

Place: Depew, NY **Date:** 07/20/2017

Signature: 

Name: Carrie Termin

Title: Regulatory Affairs and Product Certification Specialist
