



Model 691A51/03
BNC Termination Box
Installation and Operating Manual

**For assistance with the operation of this product,
contact PCB Piezotronics, Inc.**

Toll-free: 800-959-4464
24-hour SensorLine: 716-684-0001
Fax: 716-684-3823
E-mail: imi@pcb.com
Web: www.imi-sensors.com



The information contained in this document supersedes all similar information that may be found elsewhere in this manual.

Total Customer Satisfaction – PCB Piezotronics guarantees Total Customer Satisfaction. If, at any time, for any reason, you are not completely satisfied with any PCB product, PCB will repair, replace, or exchange it at no charge. You may also choose to have your purchase price refunded in lieu of the repair, replacement, or exchange of the product.

Service – Due to the sophisticated nature of the sensors and associated instrumentation provided by PCB Piezotronics, user servicing or repair is not recommended and, if attempted, may void the factory warranty. Routine maintenance, such as the cleaning of electrical connectors, housings, and mounting surfaces with solutions and techniques that will not harm the physical material of construction, is acceptable. Caution should be observed to insure that liquids are not permitted to migrate into devices that are not hermetically sealed. Such devices should only be wiped with a dampened cloth and never submerged or have liquids poured upon them.

Repair – In the event that equipment becomes damaged or ceases to operate, arrangements should be made to return the equipment to PCB Piezotronics for repair. User servicing or repair is not recommended and, if attempted, may void the factory warranty.

Calibration – Routine calibration of sensors and associated instrumentation is

recommended as this helps build confidence in measurement accuracy and acquired data. Equipment calibration cycles are typically established by the users own quality regimen. When in doubt about a calibration cycle, a good “rule of thumb” is to recalibrate on an annual basis. It is also good practice to recalibrate after exposure to any severe temperature extreme, shock, load, or other environmental influence, or prior to any critical test.

PCB Piezotronics maintains an ISO-9001 certified metrology laboratory and offers calibration services, which are accredited by A2LA to ISO/IEC 17025, with full traceability to N.I.S.T. In addition to the normally supplied calibration, special testing is also available, such as: sensitivity at elevated or cryogenic temperatures, phase response, extended high or low frequency response, extended range, leak testing, hydrostatic pressure testing, and others. For information on standard recalibration services or special testing, contact your local PCB Piezotronics distributor, sales representative, or factory customer service representative.

Returning Equipment – *Following these procedures will insure that your returned materials are handled in the most expedient manner.* Before returning any equipment to PCB Piezotronics, contact your local distributor, sales representative, or factory customer service representative to obtain a Return

Materials Authorization (RMA) Number. This RMA number should be clearly marked on the outside of all package(s) and on the packing list(s) accompanying the shipment. A detailed account of the nature of the problem(s) being experienced with the equipment should also be included inside the package(s) containing any returned materials.

A Purchase Order, included with the returned materials, will expedite the turn-around of serviced equipment. It is recommended to include authorization on the Purchase Order for PCB to proceed with any repairs, as long as they do not exceed 50% of the replacement cost of the returned item(s). PCB will provide a price quotation or replacement recommendation for any item whose repair costs would exceed 50% of replacement cost, or any item that is not economically feasible to repair. For routine calibration services, the Purchase Order should include authorization to proceed and return at current pricing, which can be obtained from a factory customer service representative.

Warranty – All equipment and repair services provided by PCB Piezotronics, Inc. are covered by a limited warranty against defective material and workmanship for a period of one year from date of original purchase. Contact

PCB for a complete statement of our warranty. Expendable items, such as batteries and mounting hardware, are not covered by warranty. Mechanical damage to equipment due to improper use is not covered by warranty. Electronic circuitry failure caused by the introduction of unregulated or improper excitation power or electrostatic discharge is not covered by warranty.

Contact Information – International customers should direct all inquiries to their local distributor or sales office. A complete list of distributors and offices can be found at www.pcb.com. Customers within the United States may contact their local sales representative or a factory customer service representative. A complete list of sales representatives can be found at www.pcb.com. Toll-free telephone numbers for a factory customer service representative, in the division responsible for this product, can be found on the title page at the front of this manual. Our ship to address and general contact numbers are:

PCB Piezotronics, Inc.
3425 Walden Ave.
Depew, NY 14043 USA
Toll-free: (800) 828-8840
24-hour SensorLineSM: (716) 684-0001
Website: www.pcb.com
E-mail: info@pcb.com

The Model 691A51 Series Vibration Termination Boxes

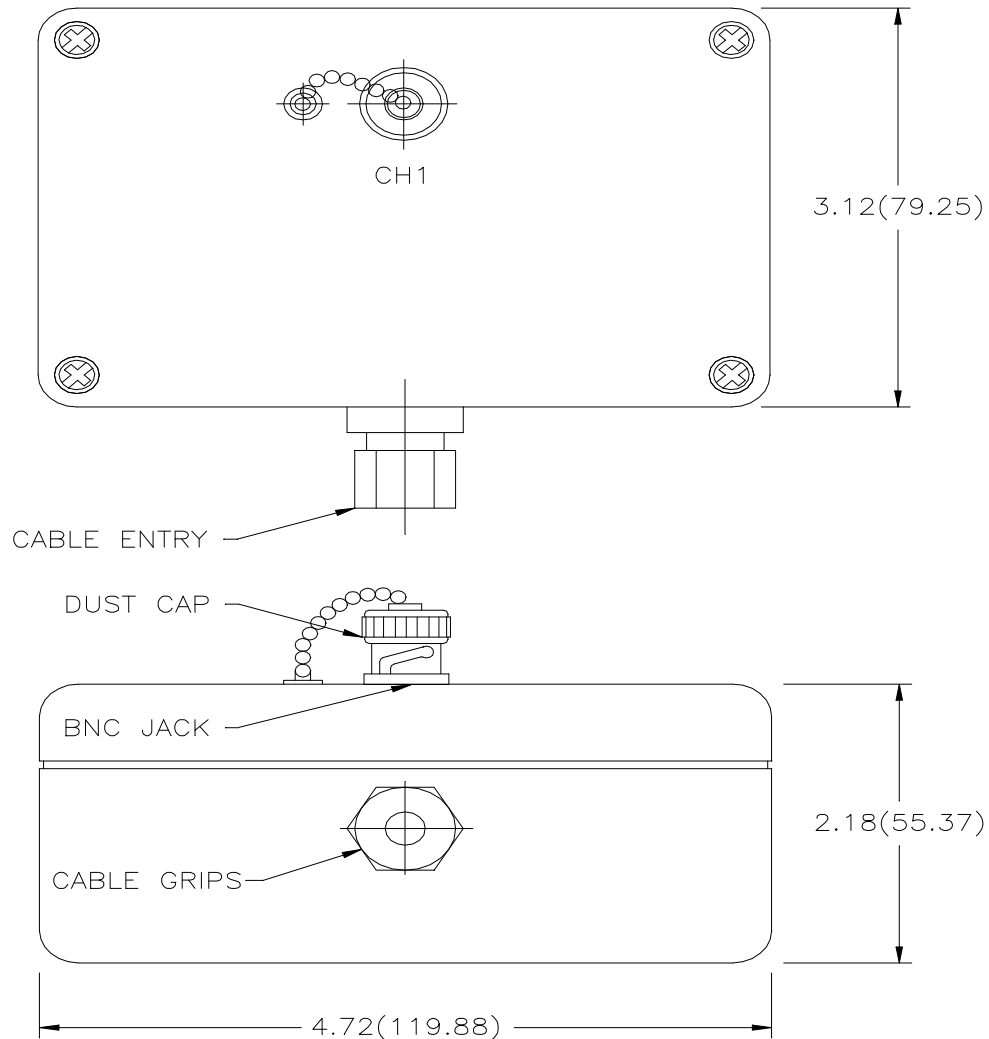

Operating Guide with Enclosed Warranty Information

3425 Walden Avenue, Depew, New York 14043-2495

Phone (716) 684-0003

Fax (716) 684-3823

Toll Free Line 1-800-959-4IMI

MANUAL NUMBER: 18424
MANUAL REVISION: NR

table of contents

Introduction..... page 3

Installation page 3

Wiring pages 4-5

Figure 1 – Typical Input Channel Wiring pages 4-5

Calibration page 5

ESD Warning Information..... page 6

warranty/servicing

Warranty, Service & Return Procedure page 7

Customer Service..... page 8

introduction

The Model 691A51 Series Vibration Termination Boxes provide terminal strip input with the convenience of BNC outputs. They are used in conjunction with commercially available data collectors and analyzers. A few specifications are listed below for easy reference.

689A51 Specifications

691A51/01	1 Channel
691A51/02	2 Channels
691A51/03	3 Channels
691A51/04	4 Channels
Input Connectors.....	3 Socket Terminal Strip
Output Connector(s)	BNC Jack
Enclosure Type.....	NEMA 4X (IP67)
Size.....	4.72 x 3.14 x 2.16 in [120 x 80 x 55 mm]
Weight.....	0.72 lbs [327 gms]

installation

Establish an easily accessible location for installation, keeping in mind the cabling will be coming from the bottom panel of the enclosure. Use the supplied mounting feet and hardware to install the unit.

Note: The unit has BNC connectors that can be easily contaminated. Install the unit away from sprays, cleaning fluids, steam, excess temperature (above 212 °F) and other contaminants. Always leave the dust cap on the BNC when not taking data. This will protect the contacts. Do not use the unit outdoors unless it is protected from the environment.

wiring

Remove outer cover of the enclosure by loosening the four screws located on the front panel. Strip cable approximately 1/8" to 3/16" (Note the length of the conductor as not to short any neighboring cables). Feed cables through cable grips.

To connect cable, push down on the top spring loaded terminal strip connector. Push the conductor into the connector (front), then remove the screwdriver. This will clamp the cable conductors onto the terminal strips. Slightly pull on the conductor to make sure that it was installed correctly. Tighten the cable clamp nut located on the outside of the enclosure. This will hold the cable jacket and also protect the internal connections from environmental contaminants.

figure 1 – typical input channel wiring

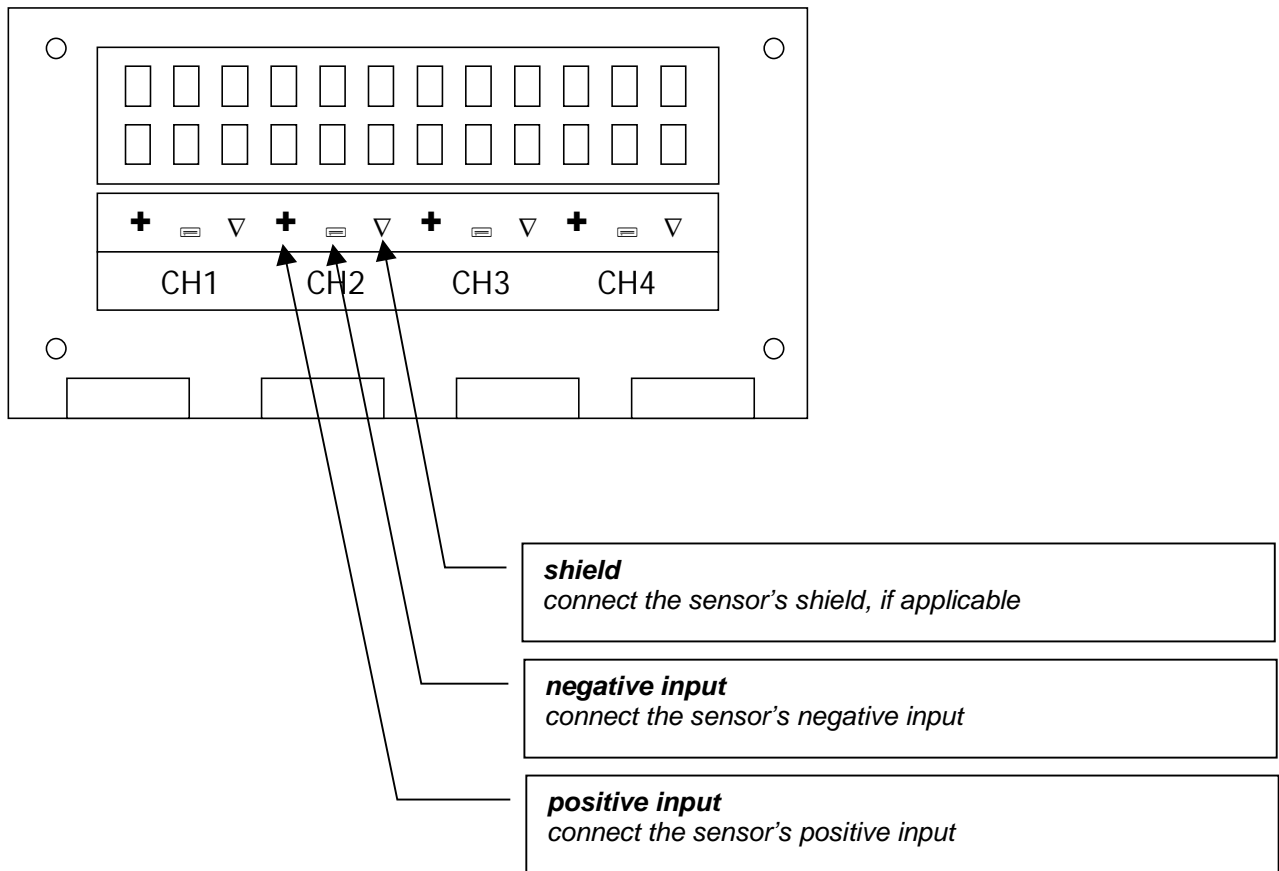
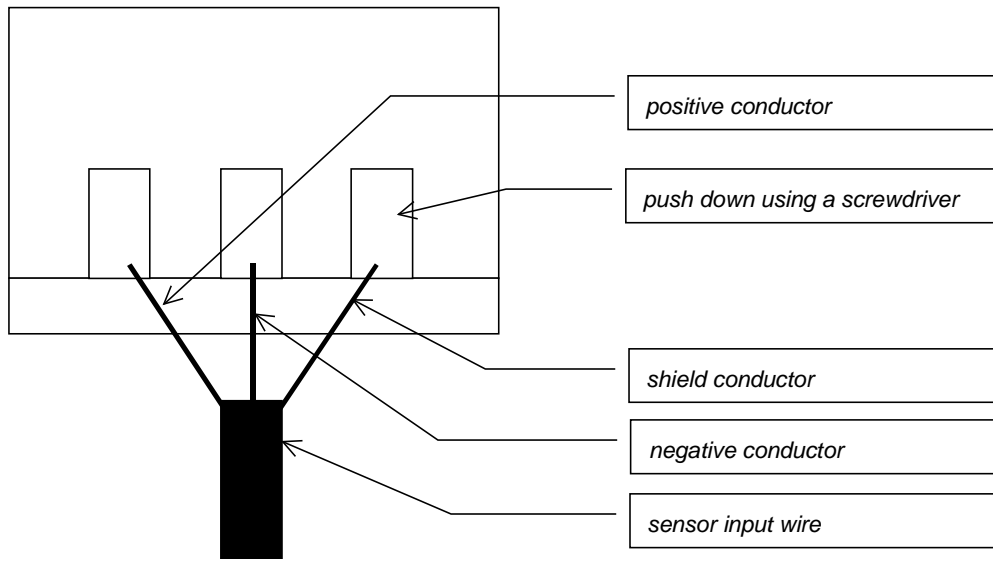

figure 1 – typical input channel wiring continued . . .



calibration

The 691A51 series does not need any calibration. If there are any questions concerning these products, please contact the factory.

warning 1 – ESD sensitivity

The power supply/signal conditioner should not be opened by anyone other than qualified service personnel. This product is intended for use by qualified personnel who recognize shock hazards and are familiar with the safety precautions required to avoid injury.

warning 2 – ESD sensitivity

This equipment is designed with user safety in mind; however, the protection provided by the equipment may be impaired if the equipment is used in a manner not specified by PCB Piezotronics, Inc.

caution 1 – ESD sensitivity

Cables can kill your equipment. High voltage electrostatic discharge (ESD) can damage electrical devices. Similar to a capacitor, a cable can hold a charge caused by triboelectric transfer, such as that which occurs in the following:

- Laying on and moving across a rug,
- Any movement through air,
- The action of rolling out a cable, and/or
- Contact with a non-grounded person.

The PCB solution for product safety:

- Connect the cables only with the AC power off.
- Temporarily “short” the end of the cable before attaching it to any signal input or output.

**caution 2 – ESD sensitivity**

ESD considerations should be made prior to performing any internal adjustments on the equipment. Any piece of electronic equipment is vulnerable to ESD when opened for adjustments. Internal adjustments should therefore be done ONLY at an ESD-safe work area. Many products have ESD protection, but the level of protection may be exceeded by extremely high voltage.

warranty

IMI instrumentation is warranted against defective material and workmanship for 1 year unless otherwise expressly specified. Damage to instruments caused by incorrect power or misapplication, is not covered by warranty. *If there are any questions regarding power, intended application, or general usage, please consult with your local sales contact or distributor.* Batteries and other expendable hardware items are not covered by warranty.

service

Because of the sophisticated nature of IMI instrumentation, field repair is typically **NOT** recommended and may void any warranty. If factory service is required, return the instrumentation according to the "Return Procedure" stated below. *A repair and/or replacement quotation will be provided prior to servicing at no charge.* Before returning the unit, please consult a factory IMI applications engineer concerning the situation as certain problems can often be corrected with simple on-site procedures.

return procedure

To expedite returned instrumentation, contact a factory IMI applications engineer for a RETURN MATERIAL AUTHORIZATION (RMA) NUMBER. Please have information available such as model and serial number. Also, to insure efficient service, *provide a written description of the symptoms and problems with the equipment to a local sales representative or distributor, or contact IMI if none are located in your area.*

Customers outside the U.S. should consult their local IMI distributor for information on returning equipment. For exceptions, please contact the International Sales department at IMI to request shipping instructions and an RMA. For assistance, please call (716) 684-0003, or fax us at (716) 684-3823. You may also receive assistance via e-mail at imi@pcb.com or visit our web site at www.pcb.com.

customer service

IMI, a division of PCB Piezotronics, guarantees **Total Customer Satisfaction**. If, at any time, for any reason, you are not completely satisfied with any IMI product, IMI will repair, replace, or exchange it at no charge. You may also choose, within the warranty period, to have your purchase price refunded.

IMI offers to all customers, at no charge, 24-hour phone support. This service makes product or application support available to our customers, day or night, seven days a week. When unforeseen problems or emergency situations arise, call the **IMI Hot Line at (716) 684-0003**, and an application specialist will assist you.



3425 Walden Avenue, Depew, NY 14043-2495
Phone: (716) 684-0003 • USA Fax: (716) 684-3823 • INTL Fax: (716) 684-4703

**ICP ® is a registered trademark of PCB Piezotronics, Incorporated,
which uniquely identifies PCB sensors that incorporate built-in microelectronics.**

Model Number
691A51/03

BNC BREAKOUT BOX

Revision: A
ECN #: 22472

	ENGLISH	SI
Performance		
Channels	3	3
Physical		
Electrical Connector (Input)	Terminal Block	Terminal Block
Electrical Connector (Output)	BNC Jack	BNC Jack
Cable Input	PGME07	PGME07
Housing Material	Fiberglass	Fiberglass
Size (Height x Width x Depth)	4.33 in x 2.95 in x 2.16 in	110 mm x 80 mm x 55 mm
Weight	1.1 lb	.50 kg

All specifications are at room temperature unless otherwise specified.
In the interest of constant product improvement, we reserve the right to change specifications without notice.

ICP® is a registered trademark of PCB Group, Inc.

OPTIONAL VERSIONS

Optional versions have identical specifications and accessories as listed for the standard model except where noted below. More than one option may be used.

Entered: <i>JH</i>	Engineer: <i>ACE</i>	Sales: <i>DA</i>	Approved: <i>UF</i>	Spec Number:
Date: <i>7/5/05</i>	Date: <i>7/6/05</i>	Date: <i>7-6-05</i>	Date: <i>7/7/05</i>	20372

 **IMI SENSORS**
A PCB PIEZOTRONICS DIV.
3425 Walden Avenue, Depew, NY 14043

Phone: 800-959-4464
Fax: 716-684-3823
E-Mail: imi@pcb.com

8522

PCB Piezotronics Inc. claims proprietary rights in the information disclosed herein. Neither it, nor any reproduction thereof will be disclosed to others without written consent of PCB Piezotronics Inc.

APPLICATION		
NEXT ASS'Y	USED ON	VAR

REVISIONS				
REV	DESCRIPTION	ECN	DATE	APP'D
B	REVISED PER ECN	22244	5/27/05	<i>cmblor</i>

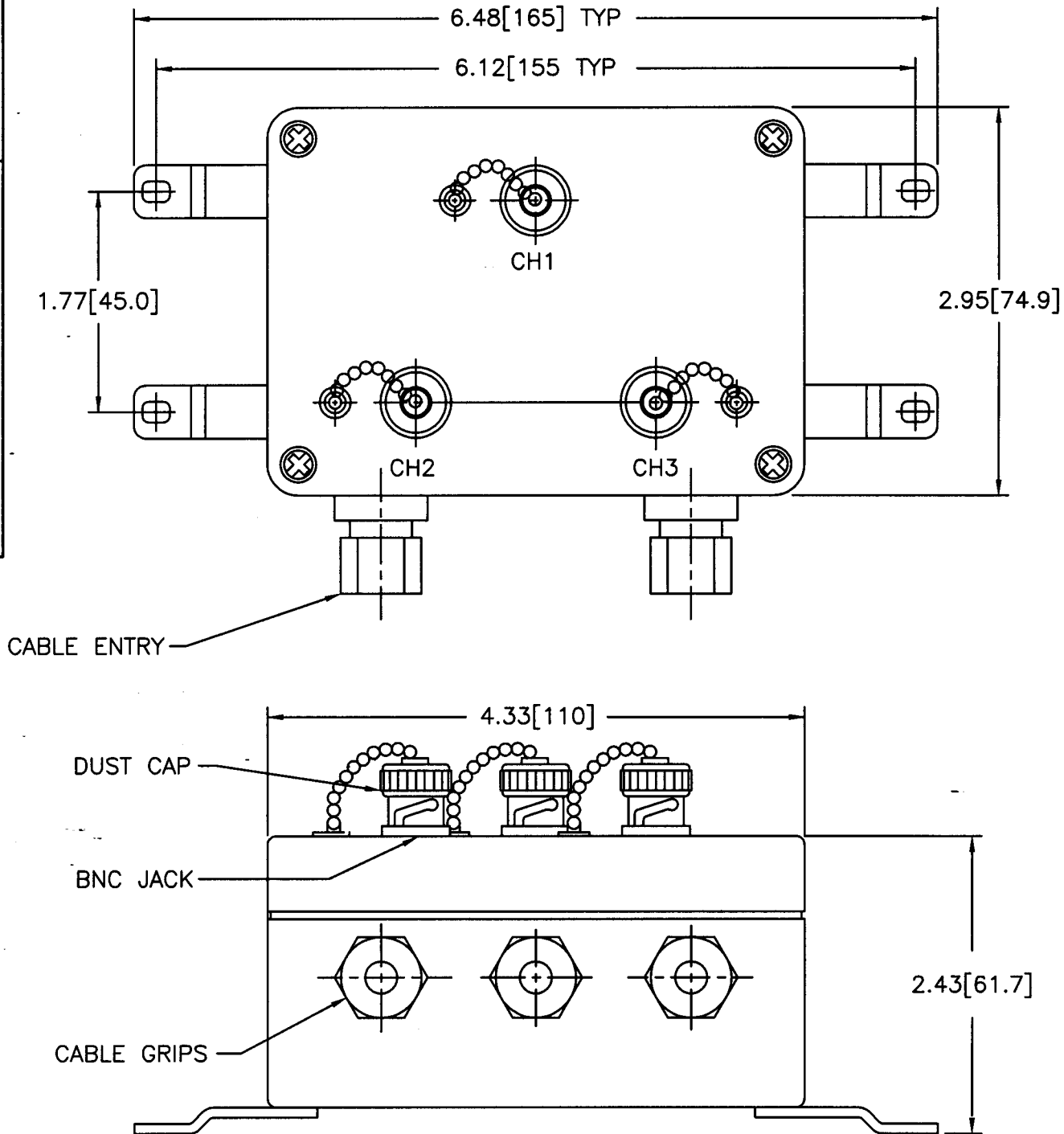

UNLESS SPECIFIED TOLERANCES		DRAWN		MFG		PCB PIEZOTRONICS™	
DIMENSIONS IN INCHES	DIMENSIONS IN MILLIMETERS (IN PARENTHESIS)	CHK'D	DATE	ENGR	DATE	3425 WALDEN AVE. DEPEW, NY 14043 (716) 684-0001 EMAIL: SALES@PCB.COM	
DECIMALS XX ±.01	DECIMALS XX ±0.3	APP'D	DATE	SALES	DATE	CODE IDENT. NO. 52681	DWG. NO. 8522
XXX ±.005	XXX ±0.13	TITLE				SCALE: 0.8	
ANGLES ±2 DEGREES	ANGLES ±2 DEGREES	OUTLINE DRAWING				SHEET 1 OF 1	
FILLETS AND RADII .003 - .005	FILLETS AND RADII (0.07 - 0.13)	MODEL 691A51/03					
DD011 REV. B 03/13/98		3 CHANNEL BREAKOUT ENCLOSURE					