



**Model 686C01**

**Vibration Switch**

**Installation and Operating Manual**

**For assistance with the operation of this product,  
contact PCB Piezotronics, Inc.**

**Toll-free: 800-959-4464  
24-hour SensorLine: 716-684-0001  
Fax: 716-684-3823  
E-mail: [imi@pcb.com](mailto:imi@pcb.com)  
Web: [www.imi-sensors.com](http://www.imi-sensors.com)**



**The information contained in this document supersedes all similar information that may be found elsewhere in this manual.**

**Total Customer Satisfaction** – PCB Piezotronics guarantees Total Customer Satisfaction. If, at any time, for any reason, you are not completely satisfied with any PCB product, PCB will repair, replace, or exchange it at no charge. You may also choose to have your purchase price refunded in lieu of the repair, replacement, or exchange of the product.

**Service** – Due to the sophisticated nature of the sensors and associated instrumentation provided by PCB Piezotronics, user servicing or repair is not recommended and, if attempted, may void the factory warranty. Routine maintenance, such as the cleaning of electrical connectors, housings, and mounting surfaces with solutions and techniques that will not harm the physical material of construction, is acceptable. Caution should be observed to insure that liquids are not permitted to migrate into devices that are not hermetically sealed. Such devices should only be wiped with a dampened cloth and never submerged or have liquids poured upon them.

**Repair** – In the event that equipment becomes damaged or ceases to operate, arrangements should be made to return the equipment to PCB Piezotronics for repair. User servicing or repair is not recommended and, if attempted, may void the factory warranty.

**Calibration** – Routine calibration of sensors and associated instrumentation is

recommended as this helps build confidence in measurement accuracy and acquired data. Equipment calibration cycles are typically established by the users own quality regimen. When in doubt about a calibration cycle, a good “rule of thumb” is to recalibrate on an annual basis. It is also good practice to recalibrate after exposure to any severe temperature extreme, shock, load, or other environmental influence, or prior to any critical test.

PCB Piezotronics maintains an ISO-9001 certified metrology laboratory and offers calibration services, which are accredited by A2LA to ISO/IEC 17025, with full traceability to N.I.S.T. In addition to the normally supplied calibration, special testing is also available, such as: sensitivity at elevated or cryogenic temperatures, phase response, extended high or low frequency response, extended range, leak testing, hydrostatic pressure testing, and others. For information on standard recalibration services or special testing, contact your local PCB Piezotronics distributor, sales representative, or factory customer service representative.

**Returning Equipment** – *Following these procedures will insure that your returned materials are handled in the most expedient manner.* Before returning any equipment to PCB Piezotronics, contact your local distributor, sales representative, or factory customer service representative to obtain a Return

Materials Authorization (RMA) Number. This RMA number should be clearly marked on the outside of all package(s) and on the packing list(s) accompanying the shipment. A detailed account of the nature of the problem(s) being experienced with the equipment should also be included inside the package(s) containing any returned materials.

A Purchase Order, included with the returned materials, will expedite the turn-around of serviced equipment. It is recommended to include authorization on the Purchase Order for PCB to proceed with any repairs, as long as they do not exceed 50% of the replacement cost of the returned item(s). PCB will provide a price quotation or replacement recommendation for any item whose repair costs would exceed 50% of replacement cost, or any item that is not economically feasible to repair. For routine calibration services, the Purchase Order should include authorization to proceed and return at current pricing, which can be obtained from a factory customer service representative.

**Warranty** – All equipment and repair services provided by PCB Piezotronics, Inc. are covered by a limited warranty against defective material and workmanship for a period of one year from date of original purchase. Contact

PCB for a complete statement of our warranty. Expendable items, such as batteries and mounting hardware, are not covered by warranty. Mechanical damage to equipment due to improper use is not covered by warranty. Electronic circuitry failure caused by the introduction of unregulated or improper excitation power or electrostatic discharge is not covered by warranty.

**Contact Information** – International customers should direct all inquiries to their local distributor or sales office. A complete list of distributors and offices can be found at [www.pcb.com](http://www.pcb.com). Customers within the United States may contact their local sales representative or a factory customer service representative. A complete list of sales representatives can be found at [www.pcb.com](http://www.pcb.com). Toll-free telephone numbers for a factory customer service representative, in the division responsible for this product, can be found on the title page at the front of this manual. Our ship to address and general contact numbers are:

PCB Piezotronics, Inc.  
3425 Walden Ave.  
Depew, NY 14043 USA  
Toll-free: (800) 828-8840  
24-hour SensorLine<sup>SM</sup>: (716) 684-0001  
Website: [www.pcb.com](http://www.pcb.com)  
E-mail: [info@pcb.com](mailto:info@pcb.com)



## Series 686B Smart Vibration Switch



### ***Operating Guide with Enclosed Warranty Information***

**3425 Walden Avenue, Depew, New York 14043-2495**

**Phone (716) 684-0003**

**Fax (716) 684-3823**

**Toll Free Line 1-800-959-4IMI**

**MANUAL NUMBER: 40112  
MANUAL REVISION: C  
ECO# 31250**



## Table of Contents

Section .....	Page Number
Introduction.....	4
General Features.....	4
Program Installation.....	5
Software Setup.....	5
Running the Smart Vibration Switch Software.....	8
Reading the Smart Vibration Switch Settings.....	9
Programming the Smart Vibration Switch.....	10
USB Programmable Parameters and Terminology.....	11
Actual Vibration.....	11
Alarm Threshold Parameters.....	11
Relay Contact Parameters.....	11
Power On Delay Parameters.....	11
Startup Delay Parameters.....	12
Operational Delay Parameters.....	12
Residual Vibration Level Parameters.....	12
Program Switch Button.....	12
Switch Status Button.....	12
Print Button.....	12
Save Button.....	13
Using the Configuration Number.....	13
Exit Button.....	13
Magnetically Adjustable Vibration Threshold (MAVT™).....	16
Setting the Alarm Threshold Using MAVT™.....	16
MAVT™ Procedure.....	17
System Functionality.....	18
Operating Principle.....	18
Benefits of Solid State Relays.....	18
Mounting the Smart Vibration Switch.....	19
Mounting Options.....	19
Standard Stud Mount.....	19
Adhesive Mount.....	20

Table of Contents continued on next page

***Table of Contents Continued***

Section .....	Page Number
Installation Diagrams.....	21
Legend.....	21
Indicating a High Level of Vibration in a Motor.....	22
Indicating High Levels of Vibration Simultaneously in Series (Such as Fan & Motor).....	23
Constant Siren Alarming in the Event of High Vibration Levels.....	24
Two Switches in Parallel to Monitor Two Axes Simultaneously on the Same Motor.....	25
Three Switches in Parallel to Monitor Three Motors Simultaneously.....	26
Automatic Machinery Shutdown Using an External Electro-mechanical Relay.....	27
Automatic Machinery Shutdown Using an External Electro-mechanical Relay While Monitoring 2-Axes.....	28
686B Switch and External Latching for Automatic Machinery Shutdown.....	29
Both Alarm Siren and Automatic Machinery Shutdown Using Two Switches.....	30
Automatic Machinery Shutdown Based on Normally Open Solid State Relay.....	31
Automatic machinery Shutdown of a Three Phase Electrical Motor Based on a Normally Open Solid State Relay.....	32
Optional Products.....	33
Model 480C02 Battery Powered Signal Conditioner.....	33
Model 052BR010BZ Calibration Cable.....	33
Model 080A212 Permanent Magnet.....	33
ESD Sensitivity.....	34
Series 686A Smart Vibration Switch Ordering Information.....	35
Cable Ordering Information.....	36

## Introduction

The Series 686B Smart Vibration Switch is a low-cost electronic vibration switch designed to monitor vibration levels on rotating machinery, particularly fans and cooling towers, and trip an alarm or shut down machinery, when a specified vibration limit is exceeded. An onboard accelerometer with precision microprocessor controlled electronics ensures reliable operation and accuracy. The switch contains a two-pin connector for easy drop-in replacement of mechanical vibration switches and a reliable solid state relay. Multiple units can be installed in a loop configuration for economical installation and expanded protection of critical machinery. This versatile switch can be used to replace more expensive electronic vibration switches where separate vibration output is not required and to replace troublesome mechanical vibration switches.

## General Features

- Fully USB programmable from any PC (with optional USB Programmer Kit)
- 2-pin hermetically sealed stainless steel housing for use in corrosive environments
- Imbedded Piezoelectric Accelerometer for improved accuracy and frequency response.
- Small footprint and single ¼-28 stud mounting
- Solid state (AC/DC) relay
- Universal AC or DC power
- Magnetically Adjustable Vibration Threshold (MAVT™)
- Connects with industry standard MIL-C-5015 connector or integral cable
- Programmable Features
  - Alarm threshold level
  - Normally Open (NO) or Normally Closed (NC) relay
  - Latching or non-latching relay action
  - Programmable delays
    - Power on
    - Startup
    - Operational
  - Residual vibration level
- EP - Explosion Proof (optional)
- EX – CSA approved for Intrinsically Safe and Non-Incendive for Hazardous Locations (optional)
  - Class I, Div. 2, Groups A, B, C, D
  - Ex nL IICT3 and AEx nA IICT3
- EX – CSA approved for Intrinsically Safe for Hazardous Locations (optional)
  - Class I, Div 2, Groups A, B, C, D
  - Ex nA IICT3 and AEx nA IICT3

**Note: For a complete list of product specifications, see the Smart Vibration Switch “Specification Sheets” and “Outline Drawings” at the end of this manual.**

## Program Installation

If the optional Model 600A15 USB Programmer Kit for Terminal Block Switch or 600A16 USB Programmer Kit for 2-pin MIL Switch was purchased it contains a Model 070A85 USB Programmer, EE151 software, and Model 080A212 magnet that are required for programming the Series 686B switches. The 600A15 Kit also contains a Model 042CE001AD cable for use with switches that have terminal block connectors. This program can also be downloaded from IMI's website, [www.imi-sensors.com](http://www.imi-sensors.com). This software must be installed prior to connecting the Smart Vibration Switch to the computer using the 070A85 USB Programmer. This software includes the drivers and user interface needed for programming the switch. You may need administrative login privileges on the computer being used to install these drivers. Once installed, administrative rights are not required for use.

### Software Setup

**Copy the Files:** Insert the CD containing the EE151 Software into the appropriate drive. Create a new directory on your hard drive and copy the entire contents of the disk to the directory created. Be sure to note where this new directory is located because you will need to browse to it to install the software.

**Install the Drivers and Software:** NOTE: If the computer does not find new hardware automatically as described below, the drivers can also be installed by either using the "Add Hardware" function in the Control Panel or by going to System, Hardware, Device Manager in the Control Panel. Please contact IMI if you need further assistance.

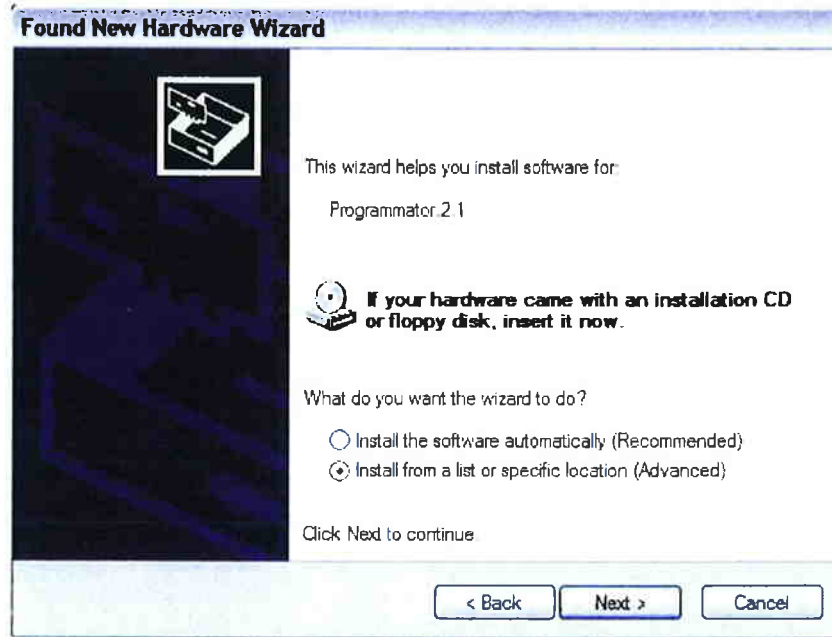
Connect the 070A85 USB Programmer first to the 2-pin MIL connector on the Series 686B Smart Vibration Switch and then to the USB connection on the computer. If the switch has a terminal block connector, use the Model 042CE001AD cable between the switch and USB Programmer. After a few seconds, you will be prompted with the following message. **Note: In some cases, you may not get this message but get the one that follows it below.**



Select "Yes, this time only" and click [Next >].



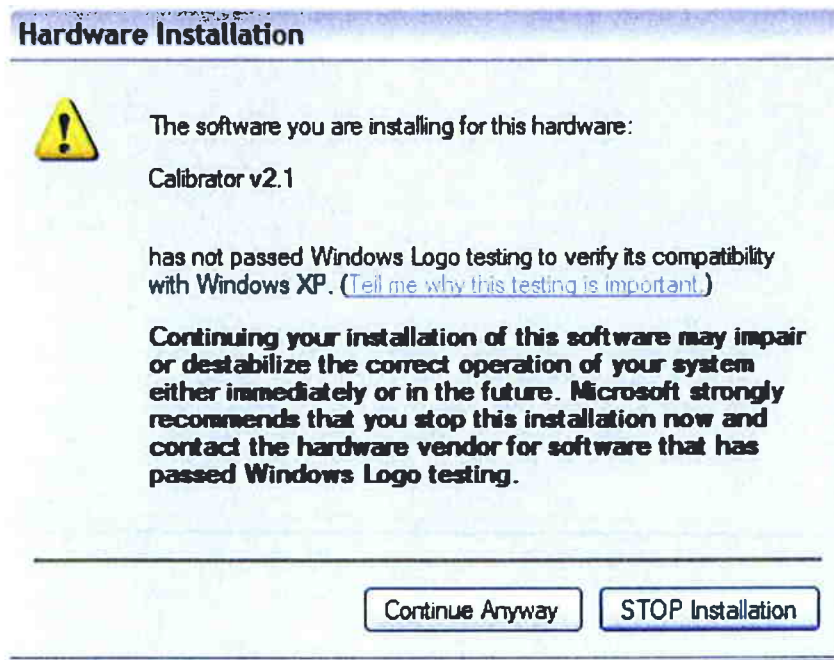
The following screen should appear, select "Install from a list or specific location" and click [Next >].



At the next screen prompt, select the option to "Include this location in the search", and click [Browse] to select the "Calibrator1Driver" folder that is a subfolder of the "EE151 Software for 686BXX" folder that is located in the folder you created in **STEP 1**. Click [Next >].



When the following screen appears; click [Continue Anyway].



The drivers should now be properly installed and you should get the following screen. Click [Finish]. The software is now ready to use.



## Running the Smart Vibration Switch Software

To run the program, refer to the figures below and follow the procedure described here.

1. Connect the Model 070A85 USP Programmer to the Series 686B Smart Vibration Switch
2. Touch the Model 080A212 (or other supplied magnet) to the indicated MAVT™ point on the Smart Vibration Switch for about 2 seconds
3. While keeping the magnet against the Smart Vibration Switch, connect the USB Programmer to your computer.
4. When the USB Programmer is connected to your computer, leave the magnet against the Smart Vibration Switch for about 5 seconds and then remove it.
5. Double click on the program icon located in the "EE151 Software for 686BXX" folder you copied from the installation CD. For convenience, you may want to create a shortcut on your desktop.



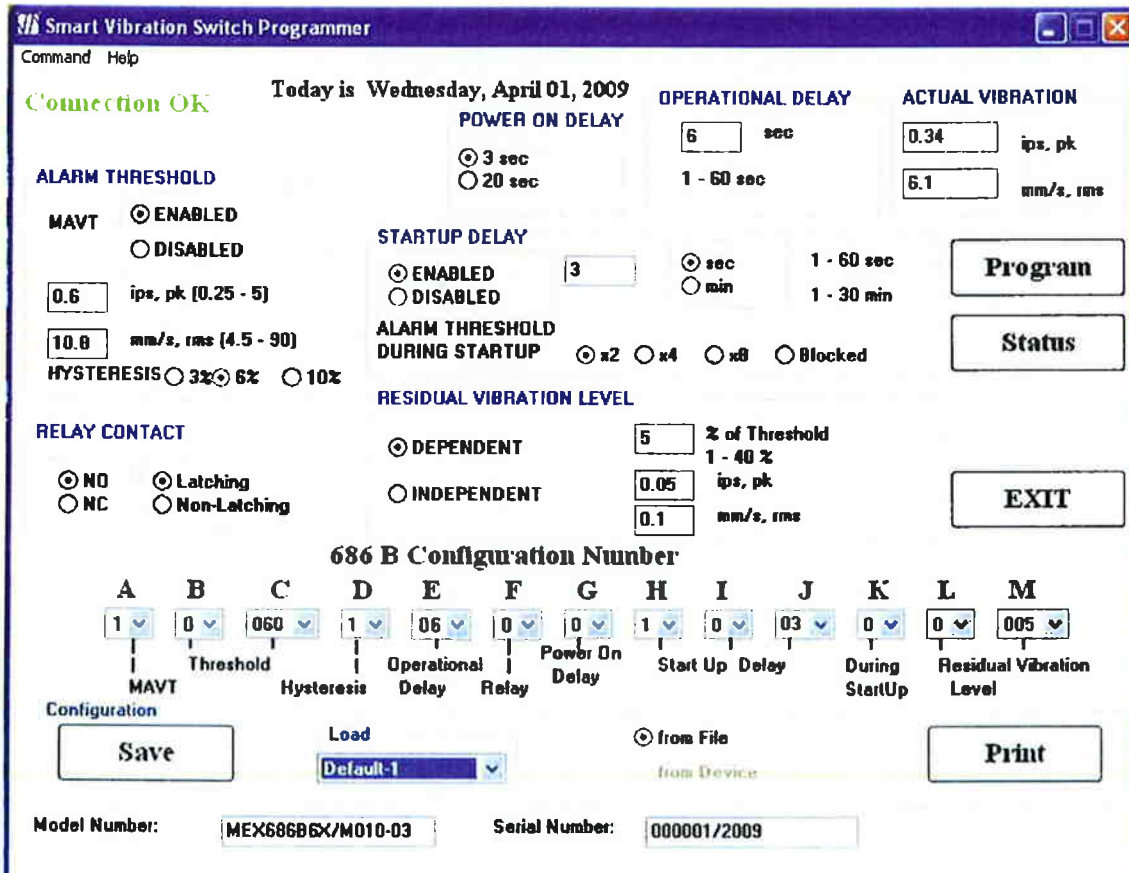
Program ICON

The program will load and display the screen on the next page. If you see the message "Connection OK" in the upper left hand corner of the screen in green print, then you have successfully communicated with the Switch. You are now ready to check switch status, change switch parameters, and program it.

If you see the message "Connection Failed" in the upper left hand corner of the screen in red print, then communication has failed and you should exit the program and try again per the instructions above. Be sure to disconnect the USB Programmer from the computer and then follow steps 2 through 5.



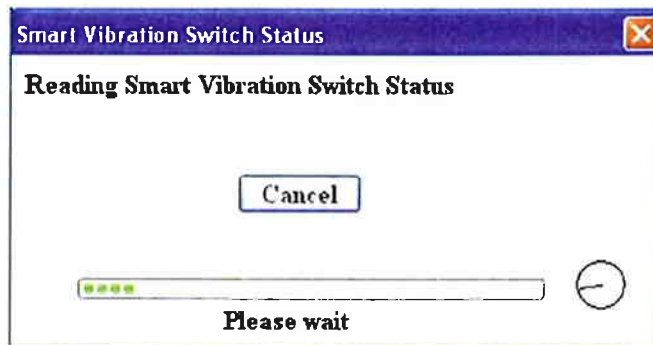
Touch magnet to MAVT™ point on the Smart Vibration Switch



Smart Vibration Switch Programmer Screen

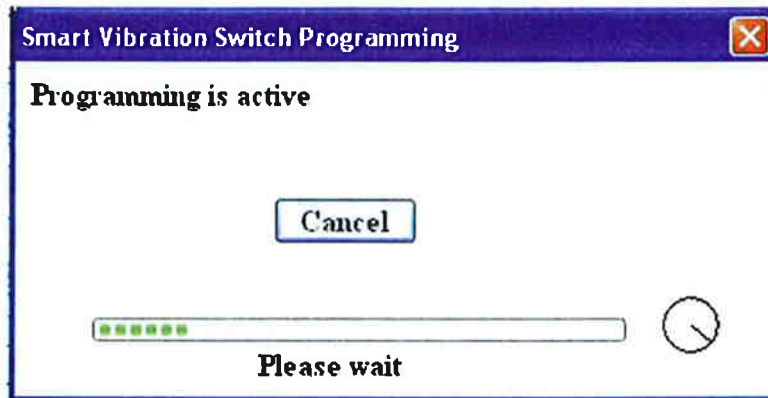
### Reading the Smart Vibration Switch Settings

**Switch Status:** To read the current settings in the Smart Vibration Switch, click on the [Status] button in the Smart Vibration Switch Programmer window. The program will display the following window while it is reading the current switch status. This may take up to 30 seconds. If the Switch is on an operating machine or a vibration shaker, the actual vibration will be read and displayed in the ACTUAL VIBRATION section of the Programmer window.



### Programming the Smart Vibration Switch

**Program Switch:** To program the Smart Vibration Switch, select the parameters that you require on the Smart Vibration Switch Programmer screen. These parameters are described in the "Programmable Parameters and Terminology" section of this manual. When the parameters are set, click on the [Program] button at the bottom of the screen. The following window will appear while the switch is being programmed. This will take about 5-minutes. The bar at the bottom of the screen will indicate the progress.



Upon completion of the switch programming, the following window will appear. Click ok. If you want to verify the new settings, run the Switch Status again. Note: If you have other windows open on your desktop, this may open behind it.



## USB Programmable Parameters and Terminology

Refer to the Smart Vibration Switch Programmer screen image on page 9. Note: When parameters are entered or changed on the Programmer screen, the corresponding parameters in the "686B Configuration Number" automatically update and vice versa.

### Actual Vibration

When the [Status] button is clicked, the software reads the current settings in the Smart Vibration Switch. It also measures the actual vibration being sensed by the switch at that time. This vibration level is displayed in the ACTUAL VIBRATION fields in both ips, pk and mm/sec, rms.

### Alarm Threshold Parameters

The Alarm Threshold is the vibration level at which the relay will change states and trip an alarm or shutdown a machine depending on how it is hooked up. This level can be set either using the MAVT™ function if enabled, or by typing in the desired vibration level in the boxes on the screen. Enter either the velocity in ips, pk or mm/sec, rms and the other is automatically set.

Hysteresis is used to keep the relay from continually changing states when the vibration level is varying around the alarm threshold level and the relay is in a non-latching mode. When the vibration reaches the alarm threshold level, the relay changes state (i.e., closes if normally open or opens if normally closed). The relay will not change states again unless the actual vibration level falls below the hysteresis value, which is set as a percentage of the alarm threshold level.

MAVT ENABLED / DISABLED - To set the alarm threshold level using the MAVT™ function, select MAVT ENABLED. See the "Magnetically Adjustable Vibration Threshold (MAVT™)" section of this manual, page 16, for instructions on using MAVT™. If you do not intend to use the MAVT™ function to set the alarm threshold level, select MAVT DISABLED.

**EXTREME CAUTION: DO NOT HAVE THE SMART VIBRATION SWITCH CONNECTED TO THE MACHINE'S TRIP CIRCUIT WHEN USING MAVT™.** The trip relay is activated several times during the procedure and will cause the machine to shut down and turn on several times. This could cause damage to your machinery.

### Relay Contact Parameters

Select NO for a Normally Open relay.

Select NC for a Normally Closed relay.

Select LATCHING for the relay to latch or stay in the alarm state until manually reset regardless of the vibration level.

Select NON-LATCHING for the relay to automatically reset once the vibration level falls below the alarm threshold (hysteresis) level.

### Power On Delay Parameters

The power on delay occurs when a non-powered switch has power applied to it. During the specified time delay, the relay will not trip regardless of the vibration level. This prevents a relay trip during high transient vibration levels that may occur during a normal machine startup. Select either the 3 sec or 20 sec Power On Delay.

### **Startup Delay Parameters**

Startup occurs in a powered switch when the actual vibration level that has been below the residual vibration level exceeds the residual vibration level (See "Residual Vibration Level Parameters" below). When this occurs, the machine is assumed to be starting up.

Select Startup Delay ENABLED OR DISABLED

Enter a delay time in the box and select sec or min (seconds or minutes)

Select an ALARM THRESHOLD DURING STARTUP as a multiplier of the normal alarm threshold value (x2, x4, or x8) or Blocked. When Blocked is selected, the relay will not trip regardless of the startup vibration level.

### **Operational Delay Parameters**

It is undesirable to have the relay trip for a short transient spike in vibration level that may not even be caused by a machine fault. The Operational Delay sets the minimum amount of time the vibration level must exceed the alarm threshold level before the relay trips. Enter the desired operation delay in seconds (1 to 60).

### **Residual Vibration Level Parameters**

The Smart Vibration Switch can be installed on a non-operating machine but still have power applied to the switch. The machine, although not running, may still have some residual vibration due to other operating machinery around it. The Smart Vibration Switch assumes the machine is not running when the sensed vibration level is below the residual vibration level. When the measured vibration level exceeds the residual vibration level, the Smart Vibration Switch assumes the machine is being started and the startup delay described above is activated.

Select DEPENDENT to set the residual alarm level as a percent of the alarm threshold level. Type in the percentage desired in the % OF ALARM THRESHOLD field.

Select INDEPENDENT to set the residual vibration level independently of the alarm threshold level. Type in the desired residual vibration level, in either ips, pk or mm/s, rms, in the field provided.

### **Program Button**

Once all of the parameters are set, click on the [Program] button to program the switch with the selected parameters. See "Programming the Smart Vibration Switch" on page 11.

### **Status Button**

Click on the [Status] button to read the currents settings of the Smart Vibration Switch and measure the actual vibration currently being sensed. See "Reading the Smart Vibration Switch Settings" on page 9.

### **Print Button**

Click on the [Print] button to print out the Smart Vibration Switch Configuration, see page 14. Note: Be sure to type in the Model Number and Serial Number of the switch before printing it out.



### **Save Button**

To save a switch configuration, click on the [Save] button, type in the File Name, and click [OK].

To load a stored configuration, click on the down arrow in the Load box, and then click on the file desired.

To delete a saved configuration file, locate the folder that contains the file on the disk and delete it.

### **Using the Configuration Number**

A switch configuration can also be set using the drop down boxes A through M. As each box is selected, the corresponding parameter on the screen will automatically be updated. Once the configuration is set, the switch must be programmed using the [Program] button.

### **Exit Button**

Click on the [EXIT] button to exit the program.



~Smart Vibration Switch Configuration~

---

Model Number: 686B01	Configuration Date:
Serial Number: 423	Monday, April 13, 2009
Description: 2-wire vibration switch	

---

A B C D E F G H I J K L M  
686B Configuration Number: 1 0 060 1 06 0 0 1 0 03 0 0 005

MAVT	ENABLED
ALARM THRESHOLD	0.6 ips, pk (10.8 mm/s rms)
HYSTERESIS	6%
OPERATIONAL DELAY	6 s
RELAY CONTACT	NO, Latching
POWER ON DELAY	3 s
STARTUP DELAY	ENABLED 3 s
ALARM THRESHOLD DURING STARTUP	x2
RESIDUAL VIBRATION LEVEL	DEPENDENT 5%



This page is intentionally left blank.

## Magnetically Adjustable Vibration Threshold (MAVT™)

Magnetically Adjustable Vibration Threshold (MAVT™) is a selectable feature via USB programming of the Series 686B Smart Vibration Switch or it can be provided from the factory with this feature enabled. This unique capability allows the alarm threshold value to be determined and set automatically by the Smart Vibration Switch based on the actual vibration level measured by it. This convenient feature permits any machine to become vibration switch protected within seconds without knowing anything about its vibration levels. Additionally, the switch can be used on a calibrated vibration shaker in the laboratory for precise setting of the alarm threshold value.

The Series 686B has no accessible mechanical adjustments, such as screw pots or DIP switches, which are found on other style electronic vibration switches; however, when fitted with the MAVT™ option, the hermetically sealed 686B becomes adjustable through magnetic actuation. By touching a specified location on the housing with a strong permanent magnet for 2-seconds (see figure below) an internal microprocessor is actuated that initiates the test sequence.

Note: The 080A212, 080A121 (or other supplied or sufficiently strong) Magnet is a supplied accessory when the Smart Vibration Switch is ordered from the factory with the MAVT™ option enabled or with the optional 600A15 or 600A16 USB Switch Programmer Kit.



### Setting the Alarm Threshold Using MAVT™

The procedure for setting the alarm threshold level on an operating machine or using a calibrated vibration shaker is very similar. In both cases, the Smart Vibration Switch must be powered. If using this feature on an operating machine, be absolutely sure you do not have the switch connected to the machine's trip circuit during this procedure. Once activated, the unit will measure the average vibration amplitude, set the alarm threshold value to two times this average value, and store this value in a non-volatile memory. This procedure will take approximately 30 seconds. After completion of this procedure on an operating machine, the switch can be hooked up to the machines trip circuit.

**EXTREME CAUTION: DO NOT HAVE THE SMART VIBRATION SWITCH CONNECTED TO THE MACHINE'S TRIP CIRCUIT WHEN USING MAVT™.** The trip relay is activated several times during the procedure and will cause the machine to shut down and turn on several times. This could cause damage to your machinery.

### MAVT™ Procedure

The Smart Vibration Switch must be powered during this procedure. Since the Smart Vibration Switch operates off universal power, any power supply that outputs 24 to 240 VDC or 24 to 240 VAC, 50 or 60 Hz will work. If calibrating on a vibration shaker or even on the operating machine prior to wiring the switch to the machines trip circuit, a simple 24V power supply/signal conditioner, like the PCB Model 480C02 (not supplied) will work well. The Model 480C02 Power Supply has the added advantage that it will visually indicate via its built-in meter when the calibration process has been completed. Use a Model 052BRXXXAC (XXX is the length in feet) or similar BNC to 2-Pin MIL cable (not supplied) to run the power from the power supply to the switch. Visit [www.imi-sensors.com](http://www.imi-sensors.com) or [www.pcb.com](http://www.pcb.com) for additional information on these products.



Model 052BRXXXAC Cable and Model 480C02 Power Supply

The alarm threshold value is preset at the factory at 0.6 in/sec peak unless otherwise requested at the time of order. If you require a different value and have MAVT™ enabled, follow this procedure. The following steps outline the basic procedure for successfully calibrating the switch.

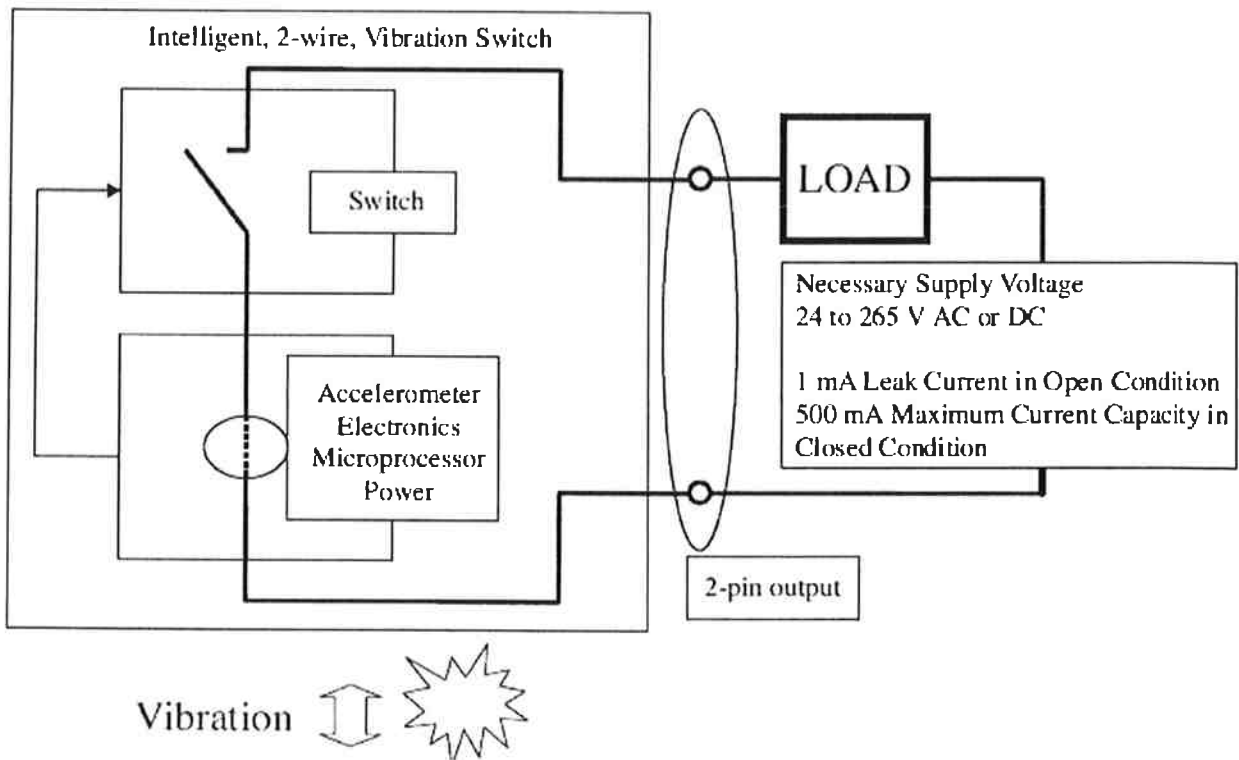
1. Mount the Smart Vibration Switch either on a variable frequency shaker or on the machine that the switch will monitor.
2. Connect the switch to the power supply using an appropriate cable. If using the Model 480C02, connect the BNC plug to the "XDCR" BNC jack on the signal conditioner and turn the unit "ON". Allow 30 seconds for the switch to power up.
3. If using a vibration shaker, determine the desired velocity alarm threshold, and set the shaker to exactly one half this value.
4. If mounting directly on a machine, be sure it is operating in a steady state condition. If it is not operating, turn the machine on and allow enough time for the vibration level to normalize before going to the next step.
5. Touch the permanent magnet to the target on the side of the switch for approximately 2 seconds to initiate the process. If using the Model 480C02, the needle on the meter will jump to the opposite side of the display, confirming the start of this process. For a period of about 30 seconds, you will see the needle bounce back and forth on the signal conditioner. This indicates that the alarm threshold calibration process is still ongoing, and occurs because the relay contacts open and close repeatedly during this process. The amount of time this takes can vary based on the difference between the previous and new alarm threshold values. When the needle stops moving back and forth, the process has been completed. At this point, the threshold value will be permanently saved until the calibration process is initiated again.
6. Disconnect the Smart Vibration Switch from the power supply.
7. The switch can now be permanently installed on the machine for protection.

Note: The Smart Vibration Switch computes peak velocity by multiplying the measured true rms velocity by 1.414.

## System Functionality

### Operating Principle

The Series 686B Smart Vibration Switch operates over just two wires. It installs in series with any load, which can be an annunciator, PLC, or relay coil. To energize itself, the vibration switch scavenges power from the load's power source. When the alarm threshold is exceeded, the switch is activated and the load's power circuit is completed to facilitate the desired alarm or shutdown.



### Benefits of Solid State Relays

A solid state relay is an electronic component that functions in the same way as an electromechanical relay, but without any moving parts. A solid state relay offers the most reliable switch action, especially for vibration applications where moving relay components run a greater risk of malfunction. They are purely electronic devices composed of a low current control side and a high current load side for switching action.

## Mounting the Smart Vibration Switch

See the Outline Drawings for the Series 686B Smart Vibration Switch at the end of this manual for full dimensional data.

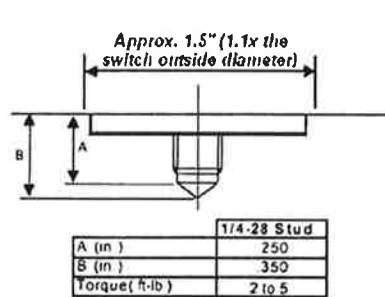
### Mounting Options

The Series 686B Smart Vibration Switch is designed to be mounted using a 1/4-28 mounting stud. The EP and EX models have a 1/4" NPT mounting thread. It is recommended that the switch be mounted directly onto the equipment being monitored, but it is also possible to use an adhesive mount for installation so the machine does not need to be drilled and tapped.

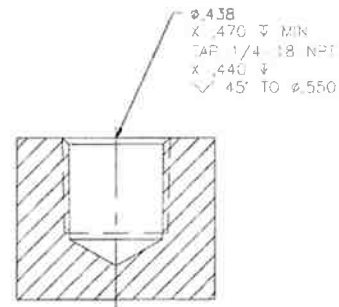
### Standard Stud Mount

A stud mount (or 1/4" NPT) is the recommended method for mounting the Series 686B switch and requires smooth flat contact surfaces for proper operation. To avoid significant reduction in the sensor's upper operating frequency range, the switch should not be mounted on curved, rough, or uneven surfaces. This increases the potential for misalignment and limited contact surface.

**Step 1:** First, prepare a smooth, flat mounting surface and then drill and tap a mounting hole in the center of this area as shown in Figure 1A or Figure 1B. A precision-machined mounting surface with a minimum finish of 63 µin (0.00016 mm) is recommended. (If it is not possible to properly prepare the machine surface, consider using an adhesive mounting pad as a possible alternative as described below.) Inspect the area checking that there are no burrs or other foreign particles interfering with the contact surface.



**Figure 1A:** Mounting surface preparation for 1/4 - 20 stud mount



**Figure 1B:** Mounting surface preparation for 1/4 NPT mount

**Step 2:** Wipe clean the mounting surface and spread on a light film of grease, oil, or similar coupling fluid prior to installation. Adding coupling fluid improves vibration transmissibility by filling in small voids in the mounting surface and increasing the mounting stiffness. Epoxy or other types of adhesives may also be used.

**Step 3:** Hand-tighten the switch to the machine and secure it with a torque wrench by applying the recommended mounting torque. (2 to 5 ft-lb.) It is important to use a torque wrench with this step. Under-torquing the switch may not adequately couple the device; over-torquing may result in stud failure and possibly permanent damage.

### Adhesive Mount

An adhesive mount can be used when the machine surface cannot be adequately prepared for stud mounting. The switch can be directly adhered to the machine, or a mounting pad can be used for easier removal for lab re-calibration using a shaker with MAVT™ models. Two- part epoxies and quick bonding gels are recommended for this type of installation. IMI Sensors offers epoxy kits in two different sizes. (Models 075A05 & 075A06) Contact the factory for pricing and additional details.

**Method 1- Direct Adhesive Mount-** Prepare a smooth, flat mounting surface. A minimum surface finish of 63  $\mu\text{in}$  (0.00016 mm) is recommended. Place a small portion of adhesive on the underside of the sensor. Firmly press down on the top of the switch to displace any adhesive remaining under the switch, Figure 2. Be aware that this mounting technique will make removal extremely difficult.

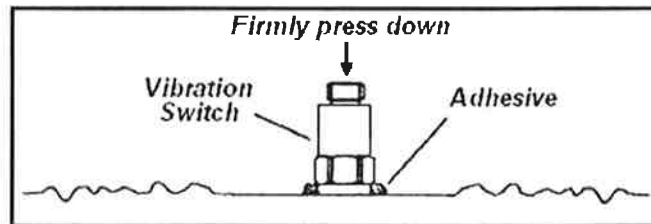


Figure 2: Direct adhesive mounting

**Method 2- Adhesive Mounting Base:** Prepare a smooth, flat mounting surface. A minimum surface finish of 63  $\mu\text{in}$  (0.00016 mm) is recommended. Stud mount the switch to the appropriate adhesive mounting base according to the guidelines set forth in **Steps 2 and 3** of the stud mount procedure. Place a small portion of adhesive on the underside of the mounting base. Firmly press down on the assembly to displace any extra adhesive remaining under the base, Figure 3.

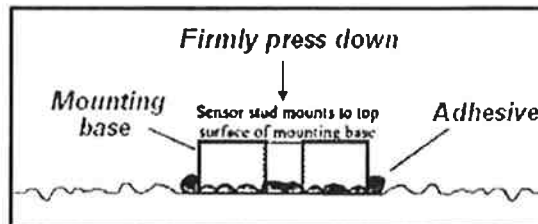


Figure 3: Mounting base, adhesive installation

## Installation Diagrams

### Legend

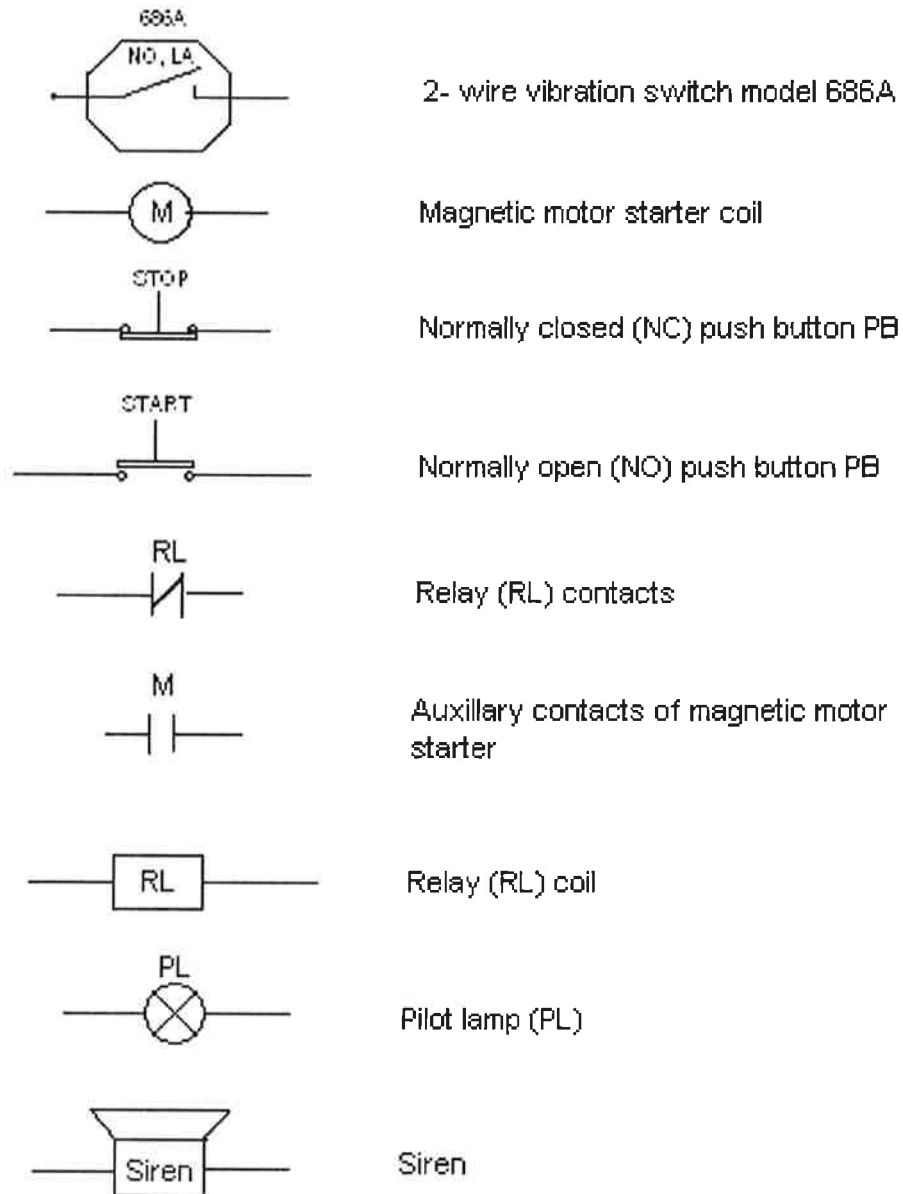
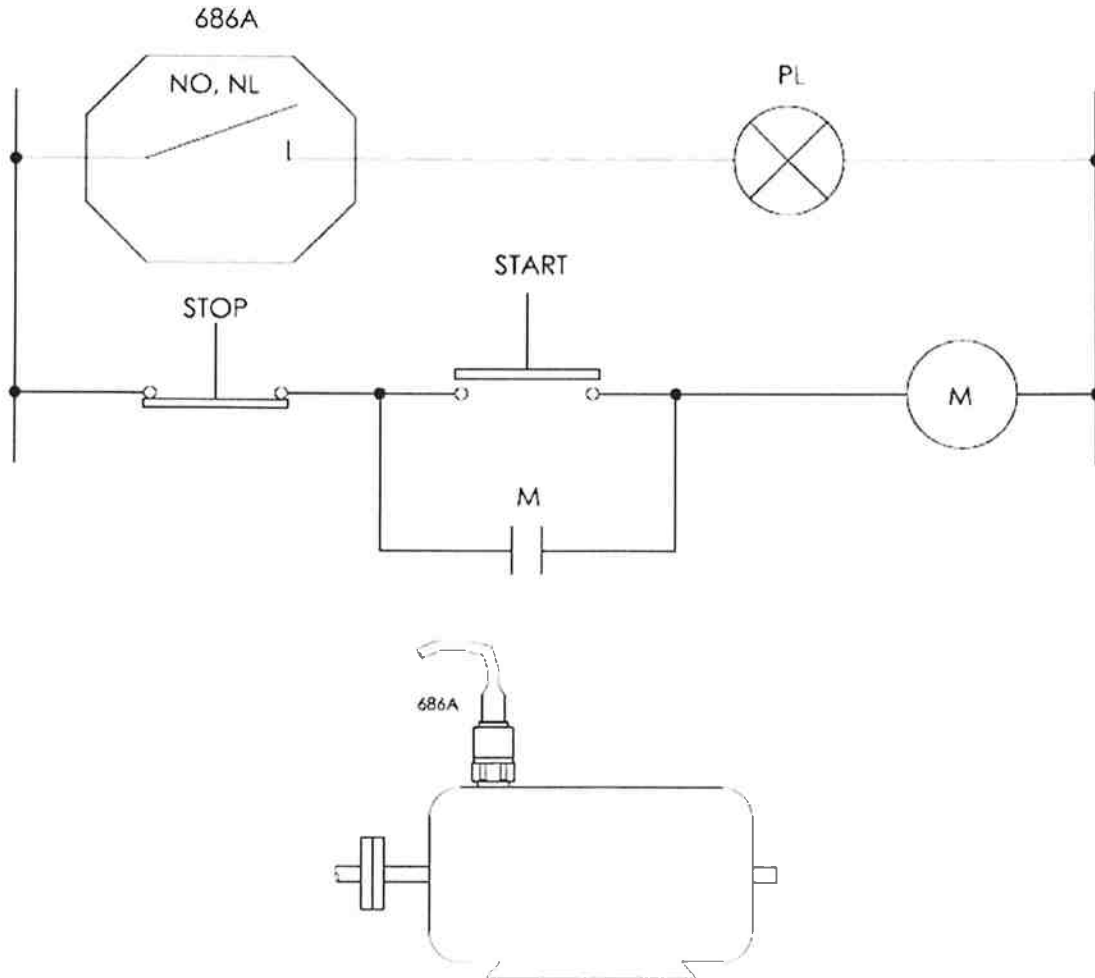




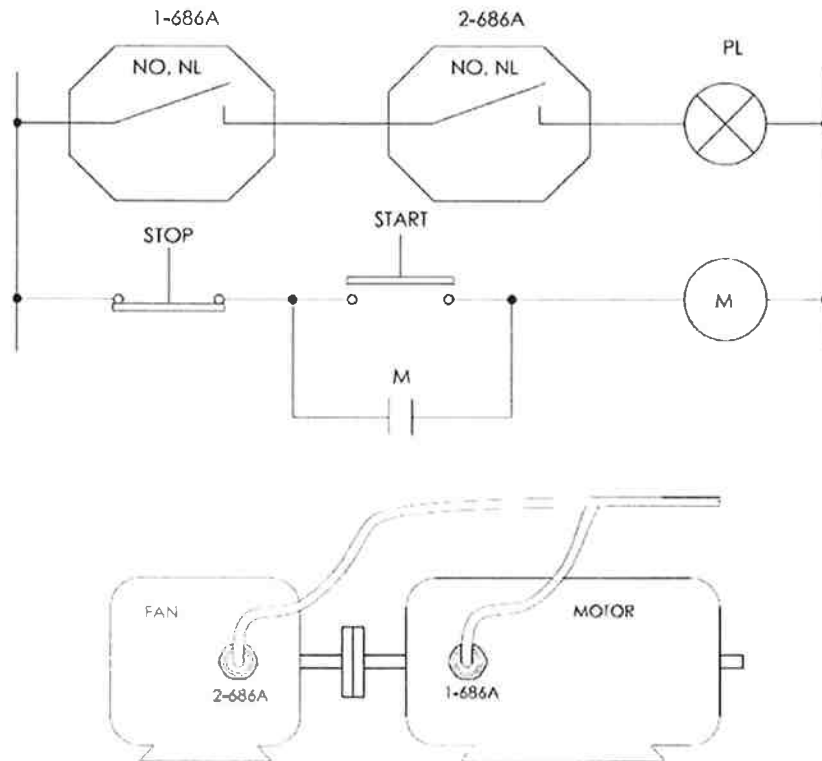
Diagram for Indicating a High Level of Vibration in a Motor



**Pushing the START PB closes the M contacts and starts the MOTOR. If the start-up delay option for the switch is enabled, the 686B01 switch will not trip regardless of the vibration level during the specified delay time. After this delay, the vibration switch will be activated. If the vibration level exceeds the alarm threshold for a time period greater than the specified operational delay time, the relay will trip. This action will close the contact to the PILOT LAMP.**

**Since the NL (non-latching) option is specified, the PILOT LAMP will illuminate only while alarm threshold is exceeded. Should the vibration level drop below the alarm threshold value (based also on the specified hysteresis), the PILOT LAMP will turn off.**

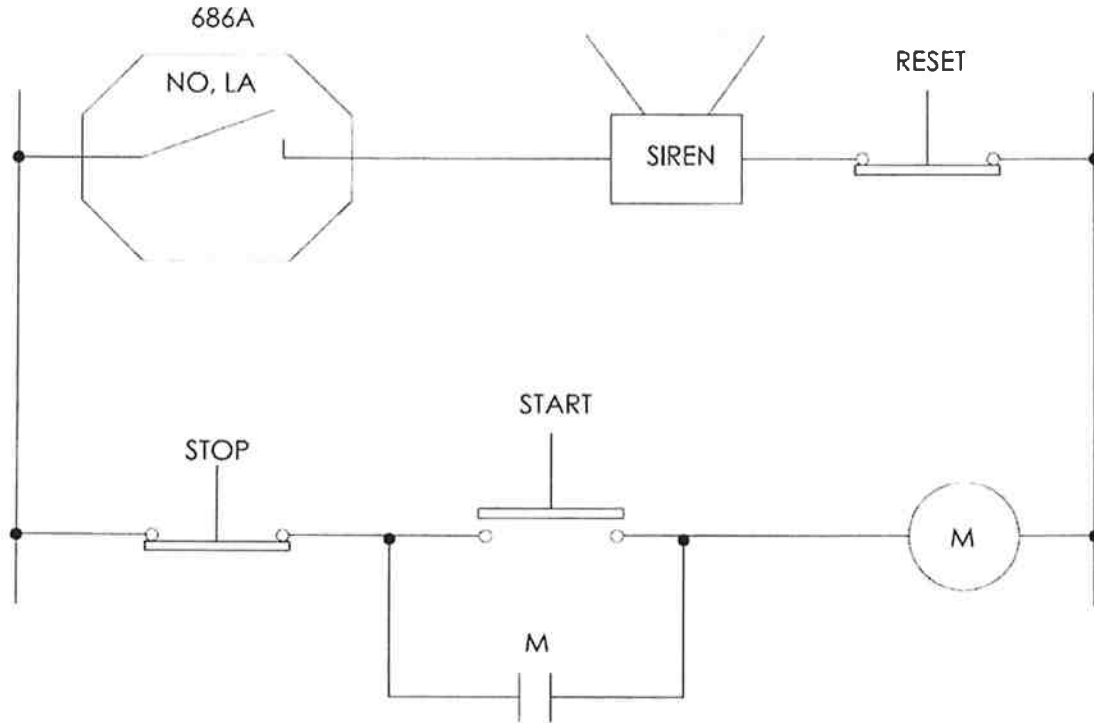
**Diagram for Indicating High Levels of Vibration Simultaneously in Series (Such as Fan & Motor)**



**The Smart Vibration Switches are hooked up in series and installed on the two most loaded bearings across the coupling in the horizontal direction. Pushing START PB closes the M contacts and starts the MOTOR and FAN. If the start-up delay option for the switches is enabled, then during the specified startup delay time, the 686B01 switches will not trip, regardless of the vibration level. After this delay, the switch relays will be activated if the vibration level on both machines exceeds the alarm threshold for a period greater than the specified operation delay time. This action will close the contact to the PILOT LAMP.**

**Since the NL (non-latching) option is specified, the PILOT LAMP will illuminate only while set threshold on both machines is exceeded. Should the vibration level for one or both of the machines drop below the threshold value (based also on the specified hysteresis), the PILOT LAMP will turn off.**

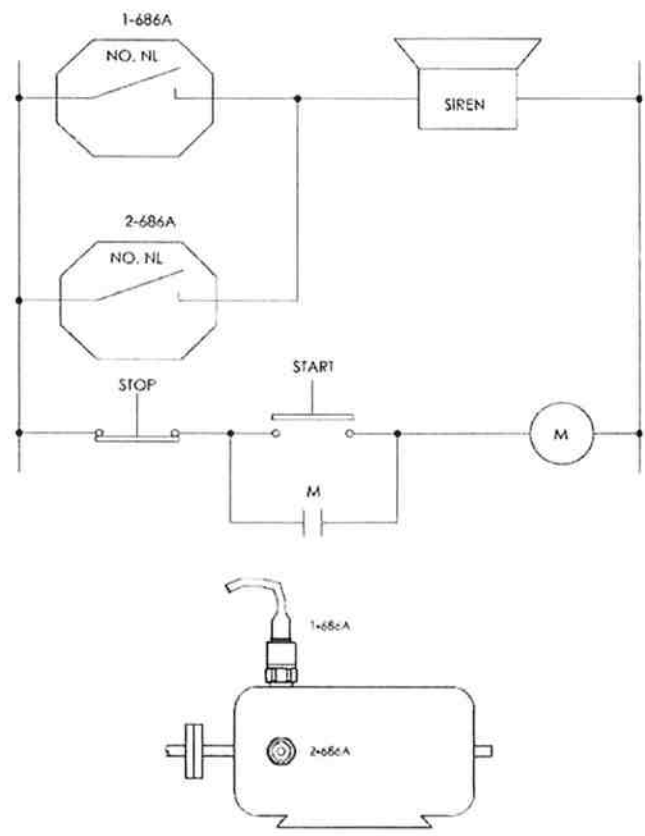
Diagram for Constant Siren Alarming in the Event of High Vibration Levels



*The Smart Vibration Switch is hooked up for automatic constant siren alarming when the alarm threshold level is exceeded. Pushing the START PB closes the M contact and starts the motor. If the start-up delay option for the switch is enabled, then during the specified startup delay time, the 686B01 switch will not trip; regardless of the vibration level. After this delay, the switch relay will be activated if the vibration level exceeds the alarm threshold for a period greater than the specified operational delay time. This action will close the contact to the ALARM SIREN and activate it.*

*Since the LA (latching) option is specified, the ALARM SIREN will be constantly energized after this high vibration event, even if the vibration level should drop below the alarm threshold. The RESET PB should be engaged to de-energize the ALARM SIREN and return the system to its original monitoring condition.*

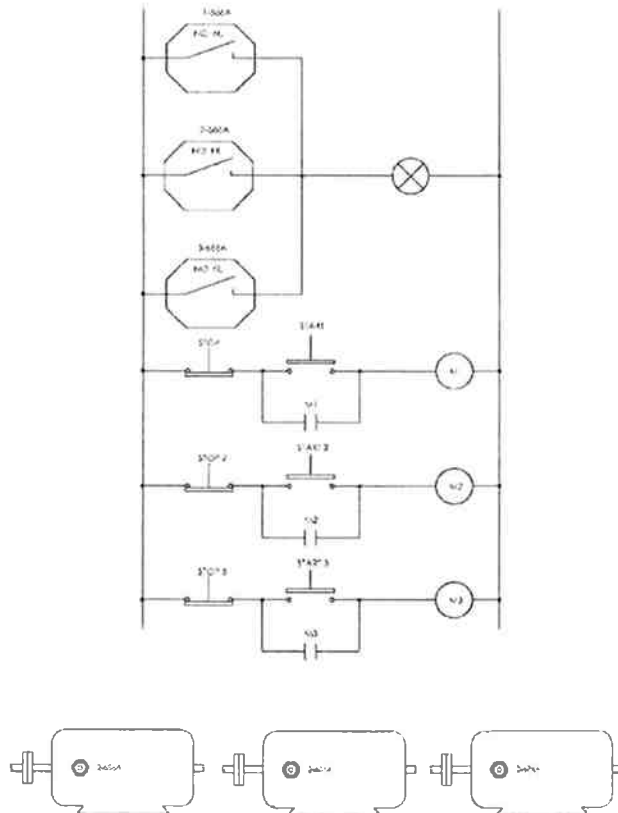
**Diagram For Using Two Switches in Parallel to Monitor Two Axes Simultaneously on the Same Motor**



***The Smart Vibration Switches are hooked up in parallel and installed on the motor in horizontal and vertical directions. Pushing START PB closes the M contact and starts the MOTOR. If the start-up delay option for the switches is enabled, then during the specified startup delay time, the 686B01 switches will not trip regardless of the vibration level. After this delay, the ALARM SIREN will be activated if EITHER of the switches experiences a vibration level over the alarm threshold lasting greater than the specified operation delay time.***

***Since the NL (non-latching) option is specified, the ALARM SIREN will sound while alarm threshold on one or both switches is exceeded. Should the vibration level for both switches drop below the alarm threshold value (based also on the specified hysteresis), the ALARM SIREN will turn off.***

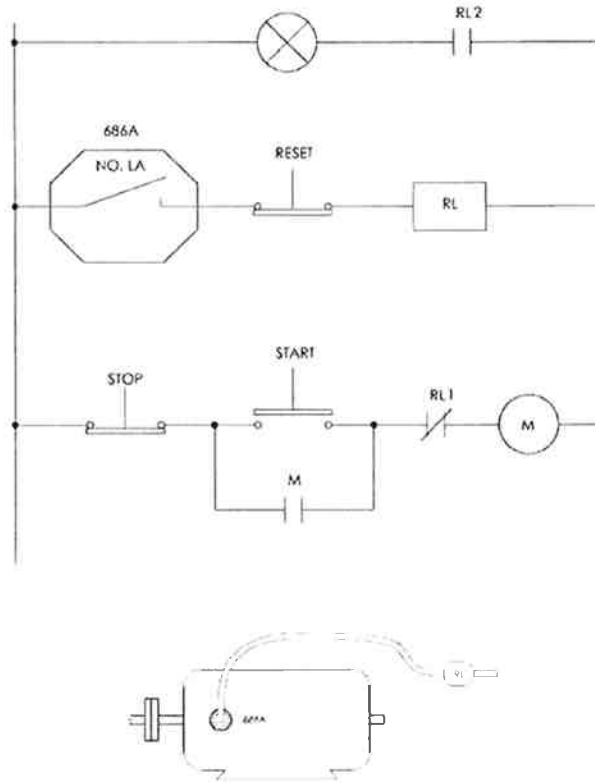
Diagram for Using Three Switches in Parallel to Monitor Three Motors Simultaneously



**The three Smart Vibration Switches are hooked up in parallel and installed on each motor in the horizontal direction. This provides an economical solution for monitoring a group of machinery while only having to run one cable. Pushing any START PB will close the corresponding M contact and start the MOTOR. If the start-up delay option for the switches is enabled, then during the specified startup delay time, the 686B01 switches will not trip; regardless of the vibration level. After this delay, the PILOT LAMP will be illuminated if ANY of the switches experience a vibration level over the alarm threshold value lasting greater than the specified operational delay time.**

**Since the NL (non-latching) option is specified, the PILOT LAMP will illuminate while alarm threshold on any of the switches is exceeded. When the vibration level for all switches drops below their alarm threshold value (based also on the specified hysteresis), the PILOT LAMP will turn off.**

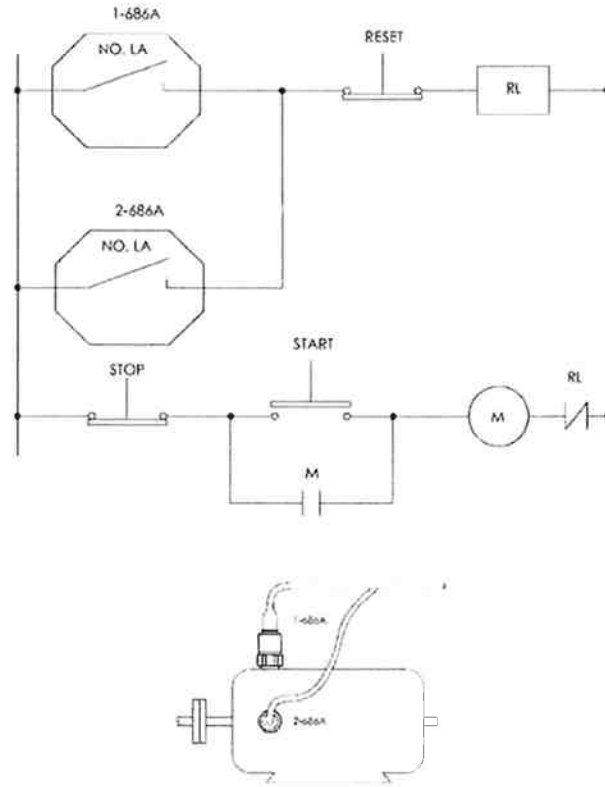
Diagram For Automatic Machinery Shutdown Using an External Electro-mechanical Relay



*The Smart vibration Switch is hooked up for automatic motor shutdown when the alarm threshold level is exceeded. The switch should be mounted in the horizontal direction on the bearing carrying the most load. Pushing the START PB closes the M contact and starts the motor. If the start-up delay option for the switch is enabled, the 686B01 switch will not trip regardless of the vibration level during the specified delay time. After this delay, the switch relay will be activated if the vibration level exceeds the alarm threshold for a period greater than the specified operational delay time. This action will close the contact and send a voltage to the RL RELAY COIL. This will open the RL1 and close the RL2 contacts, shut down the motor, and light the pilot lamp.*

*Since the LA (latching) option is enabled, the RL coil will be constantly energized after this event; even if the vibration level drops below the alarm threshold value after shutdown. The RESET PB should be pushed to reset the switch and close the RL1 and RL2 contacts before restarting the motor.*

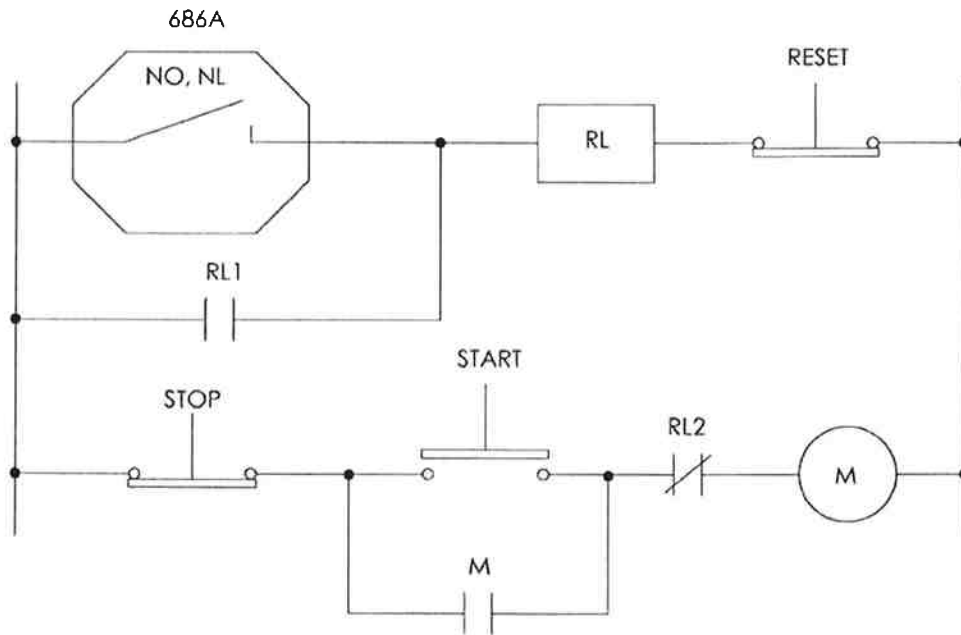
**Diagram for Automatic Machinery Shutdown Using an External Electro-mechanical Relay While Monitoring 2 Axes**



*The Smart Vibration Switches are hooked up in parallel for automatic motor shutdown when the alarm threshold level is exceeded on either switch. The switches should be mounted in the horizontal and vertical direction at the bearing carrying the most load. Pushing the START PB closes the M contact and starts the motor. If the start-up delay option for the switch is enabled, the 686B01 switch will not trip regardless of the vibration level during the specified delay time. After this delay, the switch relay will be activated if the vibration level of either switch exceeds the alarm threshold for a period greater than the specified operational delay time. This action will close the contact and send a voltage to the RL RELAY COIL. This will open the RL contacts and shut down the motor.*

*Since the LA (latching) option is specified, the RL coil will be constantly energized after this event; even if the vibration level drops below the alarm threshold value after shutdown. The RESET PB should be pushed to reset the switch and close the RL contacts before restarting the motor.*

**Diagram for Using the 686B Switch and External Latching for Automatic Machinery Shutdown**

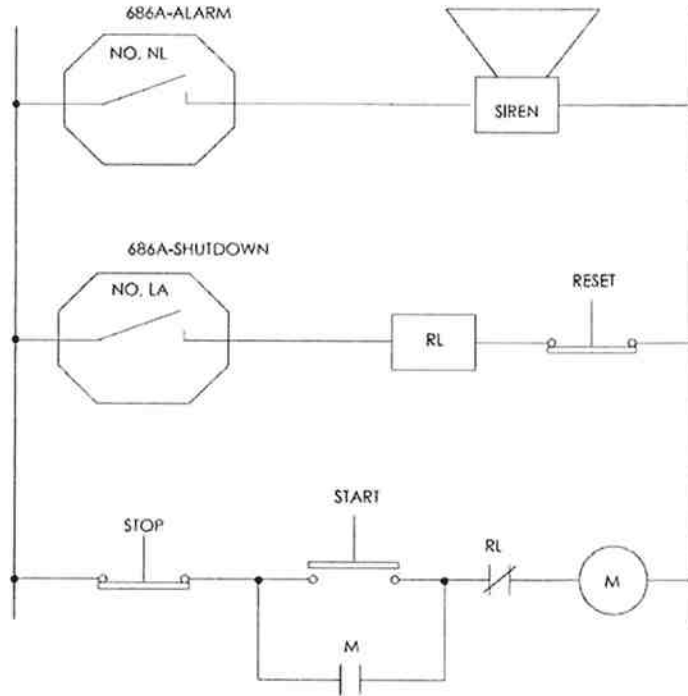


*The Smart Vibration Switches are hooked up for automatic motor shutdown in case of high vibration levels on critical machinery. Pushing the START PB closes the M contact, and since RL2 contacts are normally closed, starts the motor. If the start-up delay option for the switch is enabled, the 686B01 switch will not trip regardless of the vibration level during the specified delay time. After this delay, the switch relay will be activated if the vibration level of either switch exceeds the alarm threshold for a period greater than the specified operational delay time. This action will close the contacts and send a voltage to the RL RELAY COIL. This will open the RL2 contacts and shut down the motor.*

*Since the LA (latching) option is specified, the RL1 contacts are used for external latching. Closing of RL1 provides constant coil energizing after the shutdown event. Therefore, when the vibration level drops below the alarm threshold level after shutdown, the closed RL1 contacts still energize the RL coil and keep RL2 in the open position. The RESET PB should be pushed to reset the 2-wire switch, close the RL2 contacts, and open the RL1 contacts before restarting the motor.*

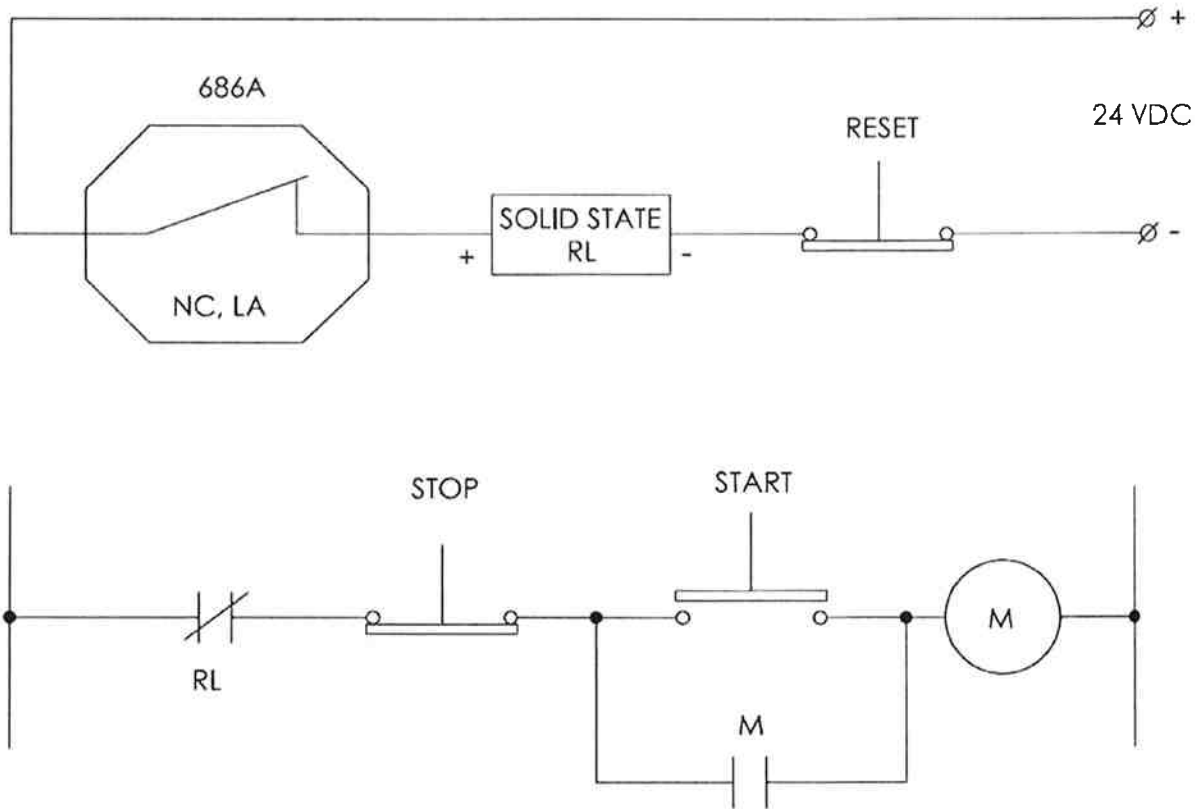


**Diagram For Both Alarm Siren and Automatic Machinery Shutdown Using Two Switches**



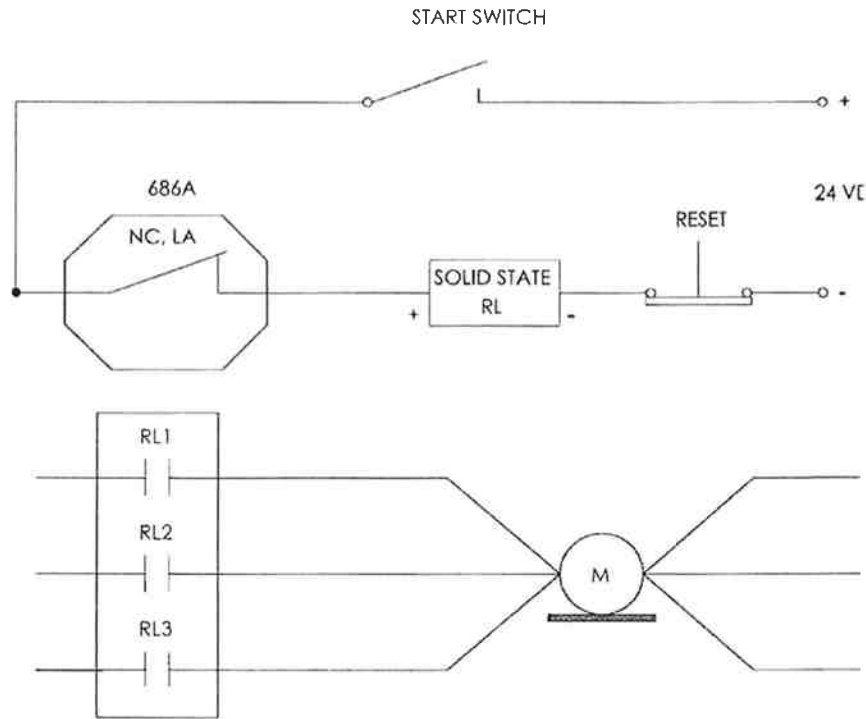
*The Smart Vibration Switches are hooked up for providing ALARM SIREN and automatic motor SHUTDOWN when the alarm threshold levels are exceeded. To accomplish this, the two switches have two different threshold values; one for ALARM and one for SHUTDOWN. Pushing the START PB closes the M contact, and since RL2 contacts are normally closed, starts the motor. If the start-up delay option for the switch is enabled, the 686BB01 switch will not trip regardless of the vibration level during the specified delay time. After this delay, if the vibration level exceeds the alarm threshold for the ALARM switch, it will be activated and apply a voltage to the ALARM SIREN. Since the NL (non-latching) option is specified for this switch, the ALARM SIREN will be energized until the vibration level falls below the alarm threshold value (based also on the specified hysteresis). If the vibration level exceeds the SHUTDOWN alarm threshold, the second vibration switch will be activated and apply a voltage to the RL RELAY COIL. This will open the RL contacts and shut down the motor. Since the LA (latching) option is specified, the RL coil will be constantly energized after this event; even though the vibration level will drop below the alarm threshold value after shutdown. The RESET PB should be pushed to reset the switch and close the RL contacts before restarting the motor.*

Diagram for Automatic Machinery Shutdown Based on Normally Open Solid State Relay



*The Smart Vibration Switch is hooked up to provide automatic motor SHUTDOWN when the alarm threshold level is exceeded. Pushing the START PB closes the M contact, and since the 686B01 switch is Normally Closed, the SOLID STATE RELAY will be energized and the RL contacts will be closed. This will start the motor. If the start-up delay option is enabled, the 686B01 switch will not trip regardless of the vibration level during the specified delay time. After this delay, if the vibration level exceeds the alarm threshold, it will be activated, thereby opening its contacts and de-energizing the SOLID STATE RELAY input. This will open the RL contacts and shut down the motor. Since the LA (latching) option is specified, the SOLID STATE RELAY input will be constantly de-energized after this event even if the vibration level drops below the alarm threshold value after shutdown. The RESET PB should be pushed to reset the switch and close the RL contacts before restarting the motor.*

**Diagram for Automatic Machinery Shutdown of a Three Phase Electrical Motor Based on a Normally Open Solid State Relay**



**The Smart Vibration Switch is hooked up to provide automatic motor SHUTDOWN when the alarm threshold level is exceeded using a NORMALLY OPEN three channel solid state relay. Closing the START SWITCH, since the 686B01 switch is NORMALLY CLOSED, will energize the SOLID STATE RELAY. This will cause the RL1, RL2, and RL3 contacts to close and start the motor. If the start-up delay option for the switch is enabled, the 686B01 switch will not trip regardless of the vibration level during the specified delay time. After this delay, if the vibration level exceeds the alarm threshold, it will be activated, thereby opening its contacts and de-energizing the SOLID STATE RELAY input. This will open the RL1, RL2, & RL3 contacts and shut down the motor. Since the LA (latching) option is specified, the SOLID STATE RELAY input will be constantly de-energized after this event; even if the vibration level drops below the alarm threshold value after shutdown. The RESET PB should be pushed to reset the switch and close the RL1, RL2, & RL3 contacts before restarting the motor. This will start the motor immediately without using the START PB. (Not shown in illustration)**

## ESD Sensitivity

### Warning 1 – ESD sensitivity

**The power supply/signal conditioner should not be opened by anyone other than qualified service personnel.** This product is intended for use by qualified personnel who recognize shock hazards and are familiar with the safety precautions required to avoid injury.

### Warning 2 – ESD sensitivity

This equipment is designed with user safety in mind; however, the protection provided by the equipment may be impaired if the equipment is used in a manner not specified by PCB Piezotronics, Inc.

### Caution 1 – ESD sensitivity

**Cables can kill your equipment.** High voltage electrostatic discharge (ESD) can damage electrical devices. Similar to a capacitor, a cable can hold a charge caused by triboelectric transfer, such as that which occurs in the following:

- Laying on and moving across a rug,
- Any movement through air,
- The action of rolling out a cable, and/or
- Contact with a non-grounded person.

#### **The PCB solution for product safety:**

- Connect the cables only with the AC power off.
- Temporarily "short" the end of the cable before attaching it to any signal input or output.



### Caution 2 – ESD sensitivity

**ESD considerations should be made prior to performing any internal adjustments on the equipment.** Any piece of electronic equipment is vulnerable to ESD when opened for adjustments. Internal adjustments should therefore be done ONLY at an ESD-safe work area. Many products have ESD protection, but the level of protection may be exceeded by extremely high voltage.

## Optional Products

### Model 480C02 Battery Powered Signal Conditioner

Power supply/signal conditioner for use with the Smart Vibration Switch when determining the alarm threshold level using the MAVT™ feature. The built-in meter indicates when the process is complete. See [www.imi-sensors.com](http://www.imi-sensors.com) for product details.



### Model 052BR010AC Calibration Cable

Model 052BR010AC is a 10 foot twisted pair shielded cable with a 2-Pin MIL type connector terminating to a BNC plug for use with 480C02 power supply and Smart Vibration Switch. See [www.imi-sensors.com](http://www.imi-sensors.com) for cable options.



### Model 080A214 Permanent Magnet Clip

Model 080A214 is a permanent magnet clip that is supplied with the optional 600A15 or 600A16 USB Programmer Kit or can be ordered separately for use with the MAVT™.



## Switch Model Number Template

### Prefix Option

- EX** CSA Approved Intrinsically Safe
- EP** Explosion Proof Condulet Enclosure
- M** Metric Installation (Not With EP or EX with Terminal Block)
- EXM** Metric EX Approved (Not With Terminal Block Connection)
- Blank** No Prefix Option

### Electrical Connection

- 0** 2 Pin Mil C 5015
- 1** Integral Cable (Model 052)
- 6** Integral Armored Cable (Model 047)
- 7** Terminal Block

### Program Configuration

- 1 1 0 060 1 06 0 0 1 0 03 0 0 005
- 2 " " " " " 1 " " " " " " " "
- 3 " " " " " 2 " " " " " " " "
- 4 " " " " " 3 " " " " " " " "
- X Custom Program Configuration (Fill out form below)

### Use for Integral Cable Models Only

M = Metric (m)  
Blank = English (ft)

### Cable Length

(Specify only if Electrical Connection is 1 or 6)  
Leave blank for default length of 10' (3m)  
Enter integral cable length, e.g., for 150 ft enter 150, for 8 meters enter 008

### Cable Termination or Connector

- (others available)
- BZ** Blunt Cut
  - AD** Pigtail
  - AC** BNC

### Armor Length

(Specify only if Electrical Connection is 6)  
Leave blank if armor length equals the cable length  
Enter armor length, e.g., for 20 ft enter 20, for 3 meters enter 03  
Maximum armor length = 50 ft (15 m)

## Custom Program Configuration

### MAVT™

<input type="checkbox"/> <b>A</b>	
<b>0</b>	Disabled
<b>1</b>	Enabled

### Alarm Threshold

<input type="checkbox"/> <b>B</b>	<input type="checkbox"/> <b>C</b>	Value = 0.25 to 5.00 ips pk or 04.5 to 90.0 mm/sec rms
<b>0</b>	English	e.g. 0.25 ips = <input type="text" value="0"/> <input type="text" value="2"/> <input type="text" value="5"/>
<b>1</b>	Metric	25.4 mm/sec = <input type="text" value="2"/> <input type="text" value="5"/> <input type="text" value="4"/>

### Hysteresis

<input type="checkbox"/> <b>D</b>	
<b>0</b>	3%
<b>1</b>	6%
<b>2</b>	10%

### Operational Delay

<input type="text" value=""/> <input type="text" value=""/>	<b>E</b>	Value = 01 to 60 sec
---	----------	----------------------

### Relay Contact

<input type="checkbox"/> <b>F</b>	
<b>0</b>	Latching, Normally Open
<b>1</b>	Latching, Normally Closed
<b>2</b>	Non-latching, Normally Open
<b>3</b>	Non-latching, Normally Closed

### Power On Delay

<input type="checkbox"/> <b>G</b>	
<b>0</b>	3 sec
<b>1</b>	20 sec

### Startup Delay

<input type="checkbox"/> <b>H</b>	<input type="checkbox"/> <b>I</b>	<input type="text" value=""/> <input type="text" value=""/>	<b>J</b>	Value = 01 to 60 sec or 01 to 30 min
<b>0</b>	Disabled	<b>0</b>	Seconds	
<b>1</b>	Enabled	<b>1</b>	Minutes	

### Alarm Threshold During Startup

(Multiplier of the Alarm Threshold)

<input type="checkbox"/> <b>K</b>	
<b>0</b>	x2
<b>1</b>	x4
<b>2</b>	x8
<b>3</b>	Blocked

### Residual Vibration Level

<input type="checkbox"/> <b>L</b>	<input type="checkbox"/> <b>M</b>	Value = For <b>Dependent</b> 001 to 040% of Alarm Threshold For <b>Independent</b> 0.01 to 5.00 ips 00.1 to 90.0 mm/sec
<b>0</b>	Dependent	
<b>1</b>	Independent	

### IMI Configuration Number:

<b>A</b>	<b>B</b>	<b>C</b>	<b>D</b>	<b>E</b>	<b>F</b>	<b>G</b>	<b>H</b>	<b>I</b>	<b>J</b>	<b>K</b>	<b>L</b>	<b>M</b>
<input type="text" value=""/>	<input type="text" value=""/>	<input type="text" value=""/>	<input type="text" value=""/>	<input type="text" value=""/>	<input type="text" value=""/>	<input type="text" value=""/>	<input type="text" value=""/>	<input type="text" value=""/>	<input type="text" value=""/>	<input type="text" value=""/>	<input type="text" value=""/>	<input type="text" value=""/>

## Factory Programmed Ordering Guide Cable Ordering Information

Go to [www.imi-sensors.com](http://www.imi-sensors.com) for complete information on cables.

IMI Part Number: 052 BR 010 BZ

**Cable Model Series**

- 052 Polyurethane, Shielded, Twisted Pair
- 048 Armored Polyurethane, Shielded, Twisted Pair

**Switch Connector Type**

- AE 2 socket MIL type with environmental boot
- BP 2 socket MIL type high temp with strain relief
- BR 2 socket MIL type molded composite
- BQ 2 socket MIL type molded composite, right angle

**Cable Length**

- 010 10 feet
- 020 20 feet
- 030 30 feet
- 040 40 feet
- 050 50 feet
- XXX Any length

**Cable termination**

- BZ Blunt Cut
- (Consult factory for additional options)*



	ENGLISH	SI	
<b>Performance</b>			
Alarm Threshold(± 10 %)	0.25 to 5 in/sec pk	4.5 to 90 mm/s rms	[1]
Frequency Range(± 3 dB)	120 to 60 kcpm	2 to 1000 Hz	
Hysteresis(% < Alarm Threshold)	3; 6; or 10 %	3; 6; or 10 %	[1]
Residual Vibration Level(Reference)	Dependent or Independent	Dependent or Independent	[1]
Residual Vibration Level(% Alarm Threshold)	1 to 40 %	1 to 40 %	[1]
MAVT(Sets Alarm Threshold to 2X actual vibration)	Enabled or Disabled	Enabled or Disabled	[1]
Transverse Sensitivity	<7 %	<7 %	
Power On Delay(± 1 sec)	3 or 20 sec	3 or 20 sec	[1]
Startup Delay(± 1 sec or 1 min)(Time)	1 to 60 sec or 1 to 30 min	1 to 60 sec or 1 to 30 min	[1]
Startup Delay(x Alarm Threshold)	x2; x4; x8; Blocked	x2; x4; x8; Blocked	[1]
Startup Delay(Active)	Enabled or Disabled	Enabled or Disabled	[1]
Operational Delay(± 1 sec)	1 to 60 sec	1 to 60 sec	[1]
Relay(Type)	SPST, Form A or B MOSFET	SPST, Form A or B MOSFET	
Relay(Latching)	Latching / Non-Latching	Latching / Non-Latching	[1]
Relay(Contacts)	Normally Open / Closed	Normally Open / Closed	[1]
<b>Environmental</b>			
Temperature Range(Operating)	-40 to 185 °F	-40 to 85 °C	
Temperature Range(Storage)	-40 to 257 °F	-40 to 125 °C	
Overload Limit(Shock)	5000 g pk	49,050 m/s <sup>2</sup> pk	
Enclosure Rating	IP68	IP68	
<b>Electrical</b>			
Power Required	24 to 240 V DC/AC 50/60 Hz	24 to 240 V DC/AC 50/60 Hz	
Current Rating(Relay Closed)	500 mA	500 mA	
Leak Current(Relay Open)	≤ 1 mA	≤ 1 mA	
Electrical Isolation(Case)	>10 <sup>8</sup> Ohm	>10 <sup>8</sup> Ohm	
<b>Physical</b>			
Size (Hex x Height)	1.25 in x 2.6 in	1.25 in x 66 mm	
Weight	5.2 oz	148 gm	
Mounting Torque	3 to 5 ft-lb	4 to 7 Nm	
Mounting Thread	1/4-28 Female	1/4-28 Female	
Sensing Element(Internal)	Piezoelectric Accelerometer	Piezoelectric Accelerometer	
Housing Material	Stainless Steel	Stainless Steel	
Sealing	Welded Hermetic	Welded Hermetic	
Electrical Connector	2-Pin MIL-C-5015	2-Pin MIL-C-5015	
Electrical Connection Position	Top	Top	

**OPTIONAL VERSIONS**

Optional versions have identical specifications and accessories as listed for the standard model except where noted below. More than one option may be used.

**EX** - Hazardous Area Approval- contact factory for specific approvals

Current Rating(Relay Closed)	100 mA	100 mA
Hazardous Area Approval	CI I, Div 2, Groups A, B, C, D; Ex nL IICT3, AEx nA IICT3	CI I, Div 2, Groups A, B, C, D; Ex nL IICT3, AEx nA IICT3
Power Required	10 to 30 VDC	10 to 30 VDC
Relay(Capacity)	10 to 30 VDC, 100 mA	10 to 30 VDC, 100 mA

**M** - Metric Mount  
Supplied Accessory : Model M081A61 Mounting Stud 1/4-28 to M6 X 1 (1)

**NOTES:**

[1] USB Programmable - See configuration sheet supplied with switch for exact setting.  
[2] See PCB Declaration of Conformance PS096 for details.

**SUPPLIED ACCESSORIES:**  
Model 081A41 Mounting stud 1/4-28 socket head set screw brass tip stainless steel 5/8" long (1)

Entered: AP	Engineer: jg	Sales: EGY	Approved: BAM	Spec Number:
Date: 2/27/2013	Date: 2/27/2013	Date: 2/27/2013	Date: 2/27/2013	<b>55110</b>



*All specifications are at room temperature unless otherwise specified.  
In the interest of constant product improvement, we reserve the right to change specifications without notice.*



**Phone: 800-959-4464**  
**Fax: 716-684-3823**  
**E-Mail: imi@pcb.com**



2

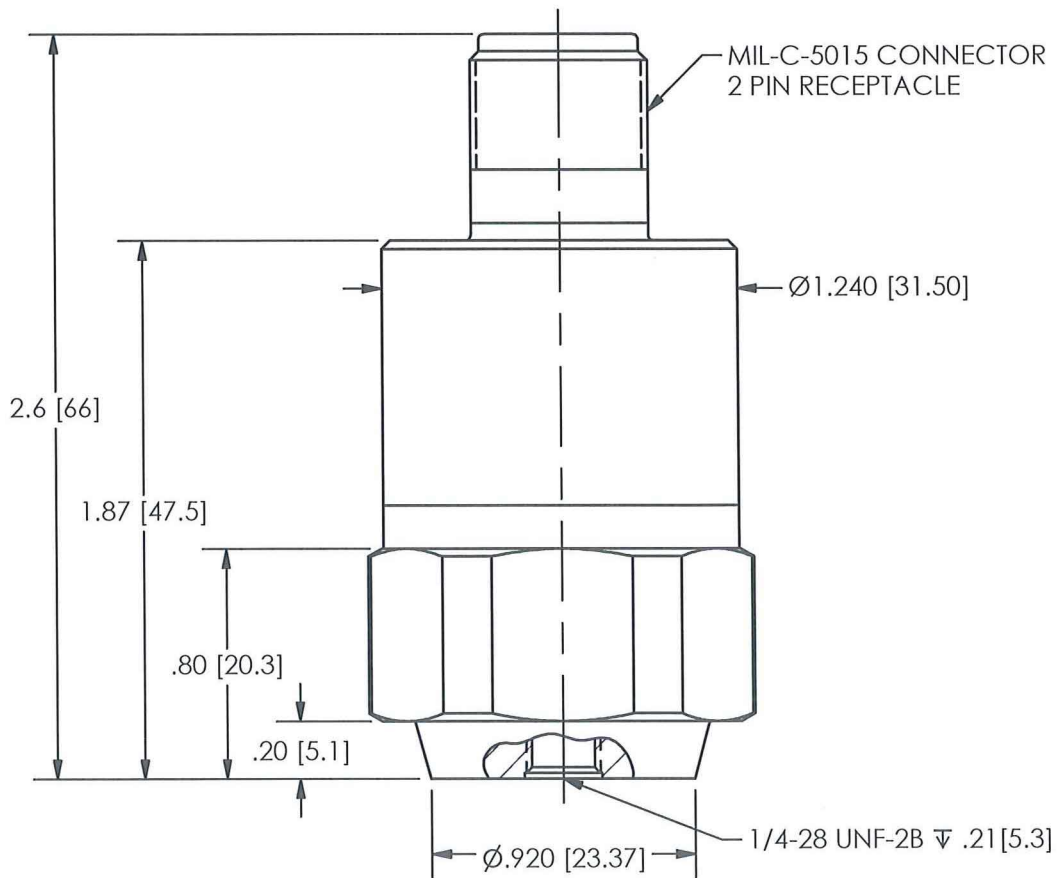
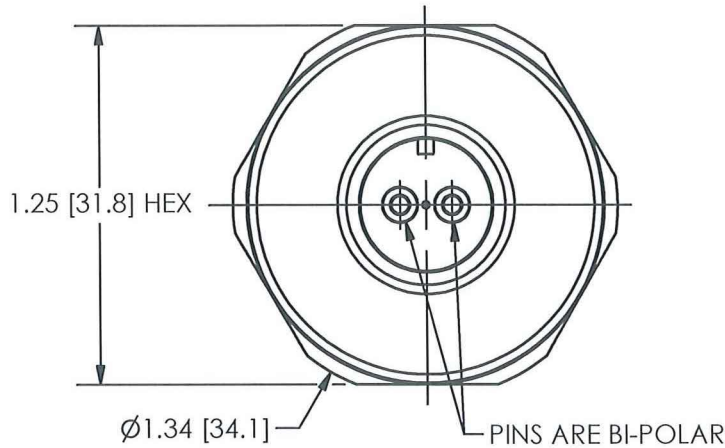
1

PCB Piezotronics Inc. claims proprietary rights in the information disclosed hereon. Neither it nor any reproduction thereof will be disclosed to others without the written consent of PCB Piezotronics Inc.

REVISIONS

REV	DESCRIPTION	DIN
A	REMOVED NOTE 1	41237

40111



UNLESS OTHERWISE SPECIFIED TOLERANCES ARE:

DRAWN

CHECKED

ENGINEER

DIMENSIONS IN INCHES

DIMENSIONS IN MILLIMETERS  
- [ IN BRACKETS ]

JDM

4/17/13

JDG

4/17/13

DECIMALS XX ±.03  
XXX ±.010

DECIMALS X ± 0.8  
XX ± 0.25

TITLE

OUTLINE DRAWING  
MODEL 686B SERIES  
VIBRATION SWITCH

ANGLES ± 2 DEGREES

ANGLES ± 2 DEGREES

FILLETS AND RADII  
.003 - .005

FILLETS AND RADII  
0.07 - 0.13

**PCB PIEZOTRONICS™**

3425 WALDEN AVE. DEPEW, NY 14043  
(716) 684-0001 E-MAIL: sales@pcb.com

CODE  
IDENT. NO.  
52681

DWG. NO.

40111

SCALE: FULL

SHEET 1 OF 1

2

1