



Model 422E55
In-Line Charge Amplifier
Installation and Operating Manual

**For assistance with the operation of this product,
contact PCB Piezotronics, Inc.**

Toll-free: 800-828-8840
24-hour SensorLine: 716-684-0001
Fax: 716-684-0987
E-mail: info@pcb.com
Web: www.pcb.com



The information contained in this document supersedes all similar information that may be found elsewhere in this manual.

Total Customer Satisfaction – PCB Piezotronics guarantees Total Customer Satisfaction. If, at any time, for any reason, you are not completely satisfied with any PCB product, PCB will repair, replace, or exchange it at no charge. You may also choose to have your purchase price refunded in lieu of the repair, replacement, or exchange of the product.

Service – Due to the sophisticated nature of the sensors and associated instrumentation provided by PCB Piezotronics, user servicing or repair is not recommended and, if attempted, may void the factory warranty. Routine maintenance, such as the cleaning of electrical connectors, housings, and mounting surfaces with solutions and techniques that will not harm the physical material of construction, is acceptable. Caution should be observed to insure that liquids are not permitted to migrate into devices that are not hermetically sealed. Such devices should only be wiped with a dampened cloth and never submerged or have liquids poured upon them.

Repair – In the event that equipment becomes damaged or ceases to operate, arrangements should be made to return the equipment to PCB Piezotronics for repair. User servicing or repair is not recommended and, if attempted, may void the factory warranty.

Calibration – Routine calibration of sensors and associated instrumentation is

recommended as this helps build confidence in measurement accuracy and acquired data. Equipment calibration cycles are typically established by the users own quality regimen. When in doubt about a calibration cycle, a good “rule of thumb” is to recalibrate on an annual basis. It is also good practice to recalibrate after exposure to any severe temperature extreme, shock, load, or other environmental influence, or prior to any critical test.

PCB Piezotronics maintains an ISO-9001 certified metrology laboratory and offers calibration services, which are accredited by A2LA to ISO/IEC 17025, with full traceability to N.I.S.T. In addition to the normally supplied calibration, special testing is also available, such as: sensitivity at elevated or cryogenic temperatures, phase response, extended high or low frequency response, extended range, leak testing, hydrostatic pressure testing, and others. For information on standard recalibration services or special testing, contact your local PCB Piezotronics distributor, sales representative, or factory customer service representative.

Returning Equipment – *Following these procedures will insure that your returned materials are handled in the most expedient manner.* Before returning any equipment to PCB Piezotronics, contact your local distributor, sales representative, or factory customer service representative to obtain a Return

Materials Authorization (RMA) Number. This RMA number should be clearly marked on the outside of all package(s) and on the packing list(s) accompanying the shipment. A detailed account of the nature of the problem(s) being experienced with the equipment should also be included inside the package(s) containing any returned materials.

A Purchase Order, included with the returned materials, will expedite the turn-around of serviced equipment. It is recommended to include authorization on the Purchase Order for PCB to proceed with any repairs, as long as they do not exceed 50% of the replacement cost of the returned item(s). PCB will provide a price quotation or replacement recommendation for any item whose repair costs would exceed 50% of replacement cost, or any item that is not economically feasible to repair. For routine calibration services, the Purchase Order should include authorization to proceed and return at current pricing, which can be obtained from a factory customer service representative.

Warranty – All equipment and repair services provided by PCB Piezotronics, Inc. are covered by a limited warranty against defective material and workmanship for a period of one year from date of original purchase. Contact

PCB for a complete statement of our warranty. Expendable items, such as batteries and mounting hardware, are not covered by warranty. Mechanical damage to equipment due to improper use is not covered by warranty. Electronic circuitry failure caused by the introduction of unregulated or improper excitation power or electrostatic discharge is not covered by warranty.

Contact Information – International customers should direct all inquiries to their local distributor or sales office. A complete list of distributors and offices can be found at www.pcb.com. Customers within the United States may contact their local sales representative or a factory customer service representative. A complete list of sales representatives can be found at www.pcb.com. Toll-free telephone numbers for a factory customer service representative, in the division responsible for this product, can be found on the title page at the front of this manual. Our ship to address and general contact numbers are:

PCB Piezotronics, Inc.
3425 Walden Ave.
Depew, NY 14043 USA
Toll-free: (800) 828-8840
24-hour SensorLineSM: (716) 684-0001
Website: www.pcb.com
E-mail: info@pcb.com

Operating Instructions

422E5X Series

1.0 INTRODUCTION

The 422E5X series charge amplifiers convert the high impedance charge signal from a charge mode transducer to a low impedance voltage signal.

This conversion is accomplished by the use of a feedback capacitor across an inverting amplifier (Fig 1). The gain of the amplifier is sufficiently high to make the charge amplifier gain virtually independent of input capacitance loading.

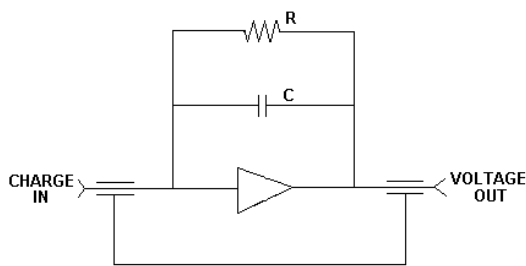

Fig 1

As in all charge amplifiers, the output is inverting. Thus, any sinusoidal signal will experience a 180 degree phase shift.

2.0 DESCRIPTION

The 422E5X series charge amps are .5 inch diameter by 3.4 inch long cylinders. One 10-32 jack functions as input, one BNC jack functions as output. The amplifier operates on power supplied by an ICP[®] power unit via a simple two-wire coaxial cable.

During operation, the electrical charge from the transducer is transferred to the feedback capacitor, resulting in a voltage given by the following equation:

$$V = Q/C_f$$

Q = the charge from the transducer

C_f = the feedback capacitance

The accompanying 9V to 12V bias voltage is typically removed by a 10uF coupling capacitor internal to most PCB ICP[®] power units.

A feedback resistor between 10⁷ and 10¹¹ ohms (depending upon the specific model) neutralizes unwanted, slowly changing signal components resulting from temperature effects and transistor leakage. This resistor, along with the feedback capacitor establishes the time constant (low frequency response).

For low level measurements or remote measurements over long cables, the 422E5X series improves the signal to noise ratio and retains the high frequency signal. The 422E5X series requires little operator attention and operates relatively drift-free in a dynamic mode, an important consideration in multi-channel installations.

3.0 INSTALLATION

Connect the 422E5X to the transducer with low noise cable (003 type only). Standard coaxial cable may be used between the amplifier and power unit, and between the power unit and readout device. (Fig 2)

Connect case of unit to Earth ground with a low impedance connection to conform to CE.

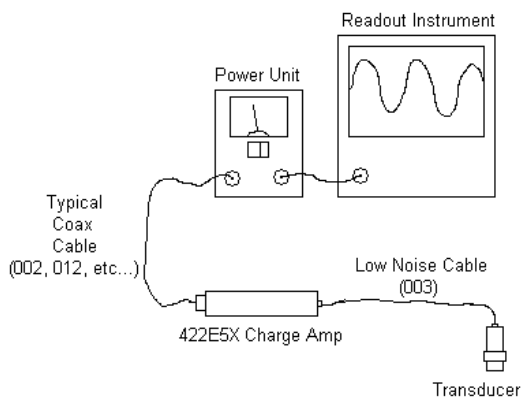

Fig 2

4.0 WARNING SYMBOLS AND TERMS

The following symbols and terms may be found on the equipment described in this manual.



This symbol on the unit indicates that excessive accumulated charges on the input cable can destroy the field effect input transistor. These charges should be grounded out by shorting the center pin of the connector plug to the outer cable conductor with a metallic object before connecting them to the 422E5X charge amp. Care should be taken to avoid touching the input terminal to any object that could possess an electric charge (such as your fingers).



This symbol on the unit indicates that the user should refer to the operating instructions located in the manual.

5.0 OPERATION

After connecting the 422E5X as indicated in Fig 2 Energize the system by turning on the power unit and waiting a few minutes for the amplifier to turn on.

For a simple, self-test circuit, monitor the +9 to +12 V DC bias existing at the output during normal operation with a high impedance voltmeter. Many PCB power units feature such a test circuit (Fig 3).

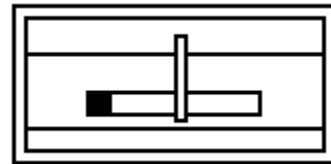

Fig 3 – A typical bias meter.

5.1 SYSTEM SENSITIVITY

When the sensitivity (pC/unit) of the transducer is known (via calibration) along with the transfer sensitivity of the charge amp (mV/pC), the system sensitivity of the system can be calculated in the following manner:

$$\text{System sens} = (\text{Xdcr Sens})(\text{Amp Sens})$$

System sens is given in (mV/Unit)

Xdcr Sens is given in (pC/Unit)

Amp Sens is given in (mV/pC)

6.0 MAINTENANCE AND REPAIR

The 422E5X charge amplifier is hermetically sealed, and requires no maintenance. If the connectors become dirty, clean with lint-free wipes dampened with isopropyl alcohol.

For extremely dirty or humid environments, the cable connections can be protected with low temperature heat shrink tubing.

Should trouble occur, the factory should be contacted for assistance.

MANUAL NUMBER: 25578

MANUAL REVISION: A

DIN NUMBER - 37900

Model Number 422E55	IN-LINE CHARGE AMPLIFIER	Revision: B ECN #: 37900
-------------------------------	---------------------------------	-----------------------------

	ENGLISH	SI	
Performance			
Sensitivity(± 2.5 %)(Charge Conversion)	0.5 mV/pC	0.5 mV/pC	
Ovrrange	± 8 V	± 8 V	
Low Frequency Response(-5 %)	0.5 Hz	0.5 Hz	
High Frequency Response(-5 %)	100 kHz	100 kHz	[2]
Non-Linearity	≤ 1.0 % FS	≤ 1.0 % FS	
Environmental			
Temperature Range(Operating)	-65 to +250 °F	-54 to +121 °C	
Maximum Shock	5000 g pk	49,050 m/s ² pk	
Maximum Vibration(5 to 2000 Hz)	100 g pk	981 m/s ² pk	
Electrical			
Excitation Voltage	+18 to 28 VDC	+18 to 28 VDC	
Constant Current Excitation	2 to 20 mA	2 to 20 mA	
Output Voltage	± 5.0 V	± 5.0 V	
Output Polarity	Inverted	Inverted	
Output Impedance	100 ohm	100 ohm	
Output Bias Voltage	+9 to 13 VDC	+9 to 13 VDC	
Maximum Input Voltage	+30 V	+30 V	
Broadband Electrical Noise(1 to 10,000 Hz)	33 µV	-90 dB	
Spectral Noise(1 Hz)	9.8 µV/√Hz	-100 dB	[1]
Spectral Noise(10 Hz)	3 µV/√Hz	-110 dB	[1]
Spectral Noise(100 Hz)	0.8 µV/√Hz	-122 dB	[1]
Spectral Noise(1 kHz)	0.4 µV/√Hz	-128 dB	[1]
Spectral Noise(10 kHz)	0.2 µV/√Hz	-134 dB	[1]
Capacitance(Feedback)	2000 pF	2000 pF	
Overload Recovery Time	10 µsec	10 µsec	
Discharge Time Constant	>1 sec	>1 sec	
Resistance(Feedback)	1.5x10 ⁹ ohm	1.5x10 ⁹ ohm	
Source Capacitance Loading(at input)	-0.0005 %/pF	-0.0005 %/pF	
Physical			
Housing Material	Stainless Steel	Stainless Steel	
Sealing	Epoxy	Epoxy	
Electrical Connector(Input)	10-32 Coaxial Jack	10-32 Coaxial Jack	
Electrical Connector(Output)	BNC Jack	BNC Jack	
Size (Diameter x Length)	0.52 in x 3.4 in	13 mm x 86 mm	
Weight	1.15 oz	32.7 gm	

OPTIONAL VERSIONS

Optional versions have identical specifications and accessories as listed for the standard model except where noted below. More than one option may be used.

NOTES:

[1] Typical.
 [2] High frequency response may be limited by supply current and output cable length.
 [3] See PCB Declaration of Conformance PS024 for details. A low impedance connection from case to earth ground is required to maintain CE compliance.

--	--	--	--	--

Entered: DMW	Engineer: KL	Sales: JJM	Approved: BAM	Spec Number:
Date: 12/14/2011	Date: 12/14/2011	Date: 12/14/2011	Date: 12/14/2011	37943



All specifications are at room temperature unless otherwise specified.
 In the interest of constant product improvement, we reserve the right to change specifications without notice.
 ICP® is a registered trademark of PCB Group, Inc.



Phone: 716-684-0001
 Fax: 716-684-0987
 E-Mail: electronics@pcb.com

3425 Walden Avenue, Depew, NY 14043

PCB Piezotronics Inc. claims proprietary rights in the information disclosed hereon. Neither it nor any reproduction thereof will be disclosed to others without the written consent of PCB Piezotronics Inc.

REVISIONS

REV	DESCRIPTION	DIN
NR	RELEASED TO DRAFTING	37900

52113

STANDARD INPUT CONNECTOR

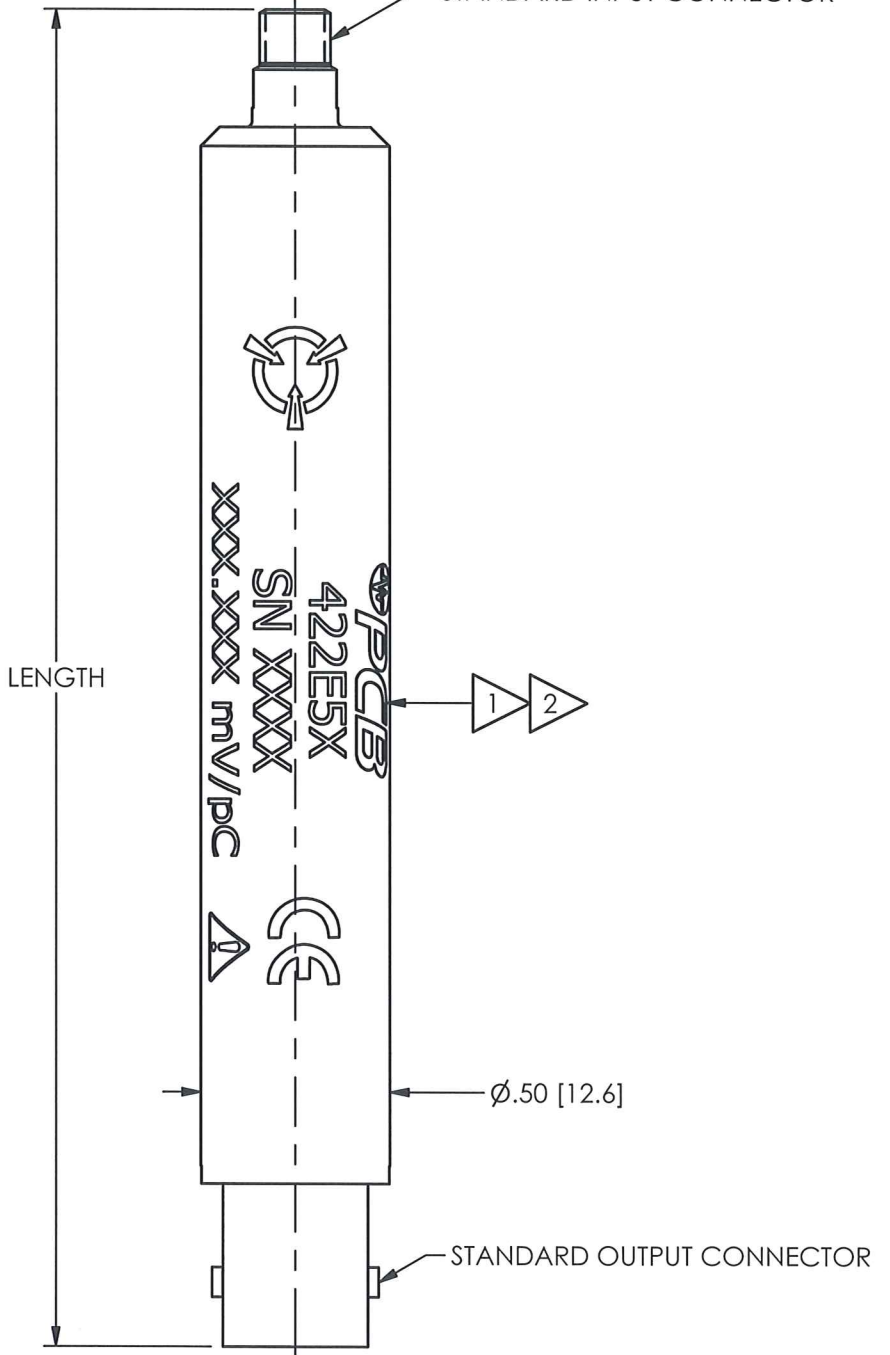

AVAILABLE CONNECTOR OPTIONS:

STANDARD MODEL NUMBER
INPUT: 10-32 MICRO DOT JACK
OUTPUT: BNC JACK
LENGTH: 3.4 [85]

MODEL NO./A
INPUT: 10-32 MICRO-DOT JACK
OUTPUT: 10-32 MICRO-DOT JACK
LENGTH: 3.0 [76]

MODEL NO./C
INPUT: 10-32 MICRO-DOT JACK
OUTPUT: BNC PLUG
LENGTH: 3.2 [81]

MODEL NO./D
INPUT: BNC JACK
OUTPUT: BNC JACK
LENGTH: 4.2 [107]

2 ETCH WITH "IN ← → OUT" TO INDICATE PROPER ORIENTATION.

1 ETCH WITH NORMAL SENSITIVITY, AS IT APPEARS ON SPEC SHEET.

UNLESS OTHERWISE SPECIFIED TOLERANCES ARE:

DIMENSIONS IN INCHES	DIMENSIONS IN MILLIMETERS [IN BRACKETS]
DECIMALS XX ±.03 XXX ±.010	DECIMALS X ± 0.8 XX ± 0.25
ANGLES ± 2 DEGREES	ANGLES ± 2 DEGREES
FILLETS AND RADII .003 - .005	FILLETS AND RADII 0.07 - 0.13

DRAWN		CHECKED		ENGINEER	
SMB	12/22/11	<i>[Signature]</i>	<i>[Signature]</i>	KEN L	12/22/11

TITLE
OUTLINE DRAWING
MODEL 422E5X SERIES
IN-LINE CHARGE AMPLIFIER

PCB PIEZOTRONICS INC.
3425 WALDEN AVE. DEPEW, NY 14043
(716) 684-0001 E-MAIL: sales@pcb.com

CODE IDENT. NO. 52681	DWG. NO. 52113
SCALE: 2X	SHEET 1 OF 1