



Model 260A02
3-Component ICP® Force Sensor
Installation and Operating Manual

**For assistance with the operation of this product,
contact PCB Piezotronics, Inc.**

Toll-free: 800-828-8840
24-hour SensorLine: 716-684-0001
Fax: 716-684-0987
E-mail: info@pcb.com
Web: www.pcb.com



The information contained in this document supersedes all similar information that may be found elsewhere in this manual.

Total Customer Satisfaction – PCB Piezotronics guarantees Total Customer Satisfaction. If, at any time, for any reason, you are not completely satisfied with any PCB product, PCB will repair, replace, or exchange it at no charge. You may also choose to have your purchase price refunded in lieu of the repair, replacement, or exchange of the product.

Service – Due to the sophisticated nature of the sensors and associated instrumentation provided by PCB Piezotronics, user servicing or repair is not recommended and, if attempted, may void the factory warranty. Routine maintenance, such as the cleaning of electrical connectors, housings, and mounting surfaces with solutions and techniques that will not harm the physical material of construction, is acceptable. Caution should be observed to insure that liquids are not permitted to migrate into devices that are not hermetically sealed. Such devices should only be wiped with a dampened cloth and never submerged or have liquids poured upon them.

Repair – In the event that equipment becomes damaged or ceases to operate, arrangements should be made to return the equipment to PCB Piezotronics for repair. User servicing or repair is not recommended and, if attempted, may void the factory warranty.

Calibration – Routine calibration of sensors and associated instrumentation is

recommended as this helps build confidence in measurement accuracy and acquired data. Equipment calibration cycles are typically established by the users own quality regimen. When in doubt about a calibration cycle, a good “rule of thumb” is to recalibrate on an annual basis. It is also good practice to recalibrate after exposure to any severe temperature extreme, shock, load, or other environmental influence, or prior to any critical test.

PCB Piezotronics maintains an ISO-9001 certified metrology laboratory and offers calibration services, which are accredited by A2LA to ISO/IEC 17025, with full traceability to N.I.S.T. In addition to the normally supplied calibration, special testing is also available, such as: sensitivity at elevated or cryogenic temperatures, phase response, extended high or low frequency response, extended range, leak testing, hydrostatic pressure testing, and others. For information on standard recalibration services or special testing, contact your local PCB Piezotronics distributor, sales representative, or factory customer service representative.

Returning Equipment – *Following these procedures will insure that your returned materials are handled in the most expedient manner.* Before returning any equipment to PCB Piezotronics, contact your local distributor, sales representative, or factory customer service representative to obtain a Return

Materials Authorization (RMA) Number. This RMA number should be clearly marked on the outside of all package(s) and on the packing list(s) accompanying the shipment. A detailed account of the nature of the problem(s) being experienced with the equipment should also be included inside the package(s) containing any returned materials.

A Purchase Order, included with the returned materials, will expedite the turn-around of serviced equipment. It is recommended to include authorization on the Purchase Order for PCB to proceed with any repairs, as long as they do not exceed 50% of the replacement cost of the returned item(s). PCB will provide a price quotation or replacement recommendation for any item whose repair costs would exceed 50% of replacement cost, or any item that is not economically feasible to repair. For routine calibration services, the Purchase Order should include authorization to proceed and return at current pricing, which can be obtained from a factory customer service representative.

Warranty – All equipment and repair services provided by PCB Piezotronics, Inc. are covered by a limited warranty against defective material and workmanship for a period of one year from date of original purchase. Contact

PCB for a complete statement of our warranty. Expendable items, such as batteries and mounting hardware, are not covered by warranty. Mechanical damage to equipment due to improper use is not covered by warranty. Electronic circuitry failure caused by the introduction of unregulated or improper excitation power or electrostatic discharge is not covered by warranty.

Contact Information – International customers should direct all inquiries to their local distributor or sales office. A complete list of distributors and offices can be found at www.pcb.com. Customers within the United States may contact their local sales representative or a factory customer service representative. A complete list of sales representatives can be found at www.pcb.com. Toll-free telephone numbers for a factory customer service representative, in the division responsible for this product, can be found on the title page at the front of this manual. Our ship to address and general contact numbers are:

PCB Piezotronics, Inc.
3425 Walden Ave.
Depew, NY 14043 USA
Toll-free: (800) 828-8840
24-hour SensorLineSM: (716) 684-0001
Website: www.pcb.com
E-mail: info@pcb.com

1.0 INTRODUCTION

ICP® force sensors incorporate a built-in MOSFET microelectronic amplifier. This serves to convert the high impedance charge output into a low impedance voltage signal for analysis or recording. ICP® sensors, powered from a separate constant current source, operate over long ordinary coaxial or ribbon cable without signal degradation. The low impedance voltage signal is not affected by triboelectric cable noise or environmental contaminants.

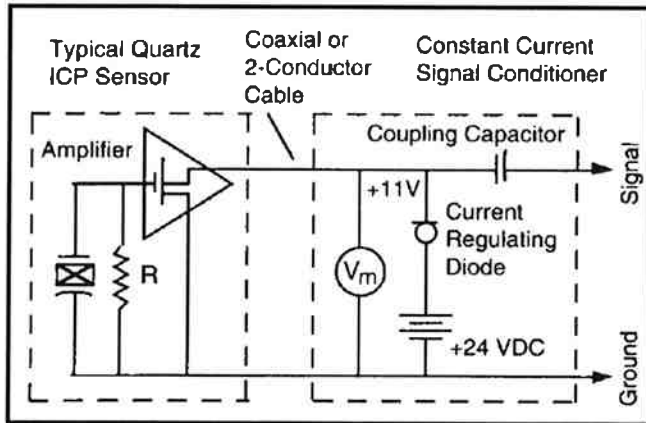

Figure 1 - ICP® Sensor System Schematic

Power to operate ICP® sensors is generally in the form of a low cost, 24-27 VDC, 2-20 mA constant current supply. **Figure 1** schematically illustrates a typical ICP® sensor system. PCB offers a number of AC or battery-powered, single or multi-channel power/signal conditioners, with or without gain capabilities for use with force sensors. (See Related Products Section of this catalog for available models.) In addition, many data acquisition systems now incorporate constant current power for directly powering ICP® sensors. Because static calibration or quasi-static short-term response lasting up to a few seconds is often required, PCB manufactures signal conditioners that provide DC coupling. **Figure 2** summarizes a complete 2-wire ICP® system configuration.

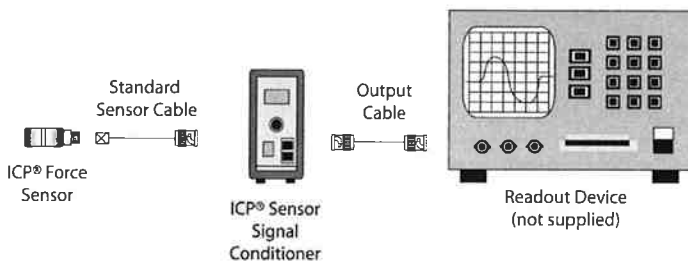

Figure 2 Typical ICP® Sensor System

ICP® force sensors are well suited for continuous, unattended force monitoring in harsh factory environments. Also, ICP® sensor cost-per-channel is substantially lower, since they operate through standard, low-cost coaxial cable, and do not require expensive charge amplifiers.

Refer to the installation/outline drawing and specification sheet at the front of this manual for details and dimensions of the particular sensor model number(s) purchased. The following pages give a brief description of the various sensor series available, recommended mounting procedures, operation and recommended calibration.

Charge mode versions with high output impedance are also available for higher temperature applications. These models can also be used for applications where it is desirable to manually set the output range. In addition to standard products, PCB has the ability to design and manufacture custom sensors/systems for specific applications.

If questions arise regarding the operation or characteristics of the force sensor products as outlined in this manual, feel free to contact an experienced applications engineer from the Force/Torque Division of PCB toll-free 888-684-0004.

2.0 DESCRIPTION

IMPACT

Series 200 Impact Sensors are designed to measure compression and impact forces from 10 lbs to 50,000 lbs (44.48 N to 22.4 kN). The flat sensing surface is located on the top of the sensor and is designed to measure force as it is applied axially to the sensor.

As highlighted in **Figure 3** compression forces directed against the sensing surface produce a positive-going output. This force-directed input and corresponding output apply to all charge mode sensors. If desired, adding the prefix "N" to a model number upon order can indicate polarity reversal.

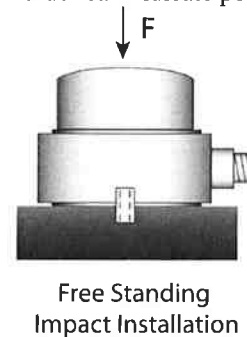

Figure 3 - Series 200 ICP® Impact Sensor

In addition to ease of operation, ICP® force sensors offer significant advantages over charge mode types. Because of the low impedance output and solid-state, hermetic construction,

Polyimide film tape covers the cap surface to reduce high frequency ringing associated with metal-to-metal impacts. Internal mounting holes with uniform 10-32 threads are prepared on each end of the sensor. Two Model 081B05-

mounting studs (M081B05 for metric installation) are supplied.

Versions offering full-scale measurement ranges of 10 lb to 5000 lb compression (45 to 22k N) and 500 lb (2,200 N) tension are available. For higher ranges, consider the dedicated ring, link, or impact style sensor configurations.

Applications include matrix print-head studies, drop testing, machinery studies, punching and forming operations, tensile testing, fatigue testing, fracture analysis, and materials testing.

RINGS

Series 201B to 207C Ring Sensors are designed to measure compression forces from 10 lbs to 100,000 lbs (44.48 N to 444.8k N).

Each sensor is provided with a calibration certificate reflecting the sensitivity of the sensor using the supplied mounting stud. If the supplied stud cannot be used for installation, PCB can provide a custom calibration using the desired bolt for accurate sensitivity readings. Using a different mounting stud will result in a sensitivity that differs from the original calibration. Refer to Section 3 for recommended force ring mounting and preload requirements.

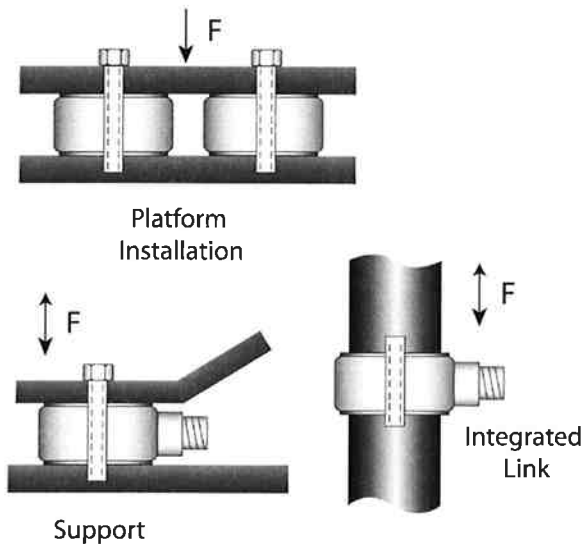

Figure 4 - Series 201 to 207 ICP® Ring Force Sensor

GENERAL PURPOSE - RADIAL

Model 208C01-C05 General Purpose Sensors are designed to measure compression and impact forces from 10 lbs to 5,000 lbs (44.48 N to 22.24 kN). Tension forces can be measured to 500 lbs. (2.224 kN). Model 084A03, a convex, stainless steel cap with integral 10-32 mounting stud is supplied for impact measurements. Polyimide film tape covers the cap surface to

reduce high frequency ringing associated with metal-to-metal impacts.

GENERAL PURPOSE - AXIAL

Models 208A11-A15 Axial Sensors provide performance and possess specifications similar to the Model 208C Sensors. These sensors are designed primarily to measure compression and impact forces from 10 lbs to 5,000 lbs (44.48 N to 22.24 kN). Tensile forces can be measured to 500 lbs (2.224 kN). The 10-32 axial electrical connector orientation associated with these sensors makes them ideal for installations where radial space is restricted or where physical connector damage may occur due to the nature of the specific application. The M7 x 0.75-6g mounting threads may be installed directly into a test structure so that the 10-32 electrical connector exits from the opposite side of the mounting fixture to prevent potential damage. This version also uses the Model 084A03 cap for impact measurements.

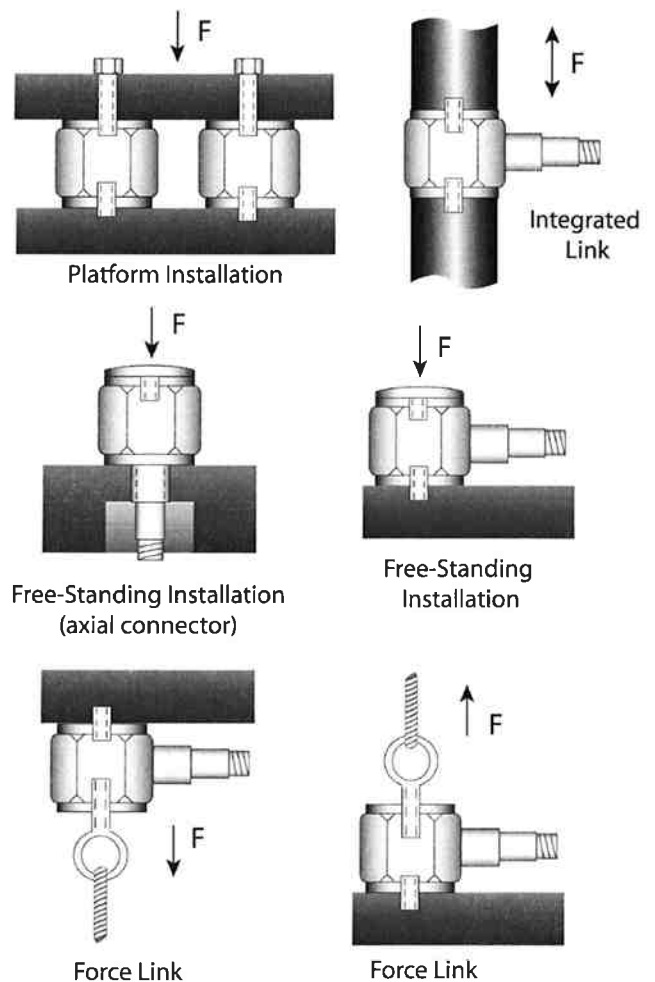

Figure 5 - Series 208 General Purpose ICP® Force Sensor

LINKS

Series 221B to 227C ICP® Link Sensors are designed for measuring compression from 10 lbs to 50,000 lbs (44.48 N to 222.4 kN), and tension forces from 10 lbs to 30,000 lbs (44.48 N to 133.4 kN). A link consists of a standard PCB ring sensor, preloaded between two hex end nuts. All hex nuts are internally threaded for mounting ease. External preloads are not required with these sensors, as they are internally preloaded during manufacture. Loosening or tightening of the hex nuts will change the internal preload of the sensor. At this point, the sensitivity provided on the calibration certificate will no longer represent that of the sensor. If this should occur, refer to the service and repair document for proper information.

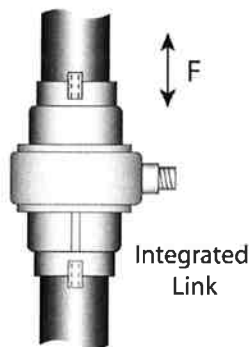

Figure 6 – Series 221 to 227 ICP® Force Link Sensor

THREE COMPONENT

3-Component force sensors are capable of simultaneously measuring force in three orthogonal directions (X, Y, and Z). They contain three sets of quartz plates that are stacked in a preloaded arrangement. Each set responds to the vector component of an applied force acting along its sensitive axis. 3-Component force sensors must be preloaded for optimum performance and linear operation. Versions are available with ranges up to 10k lb (45kN) in the Z-axis (perpendicular to the top surface), and up to 4,000 lbs (18kN) in the X and Y (shear) axes.

ICP® designs utilize built-in microelectronic circuitry that provides a low-impedance voltage output via a multi-pin connector. This arrangement offers system simplicity by requiring only a single multi-conductor sensor cable. The low impedance voltage signal makes this sensor ideal for use in harsh industrial environments.

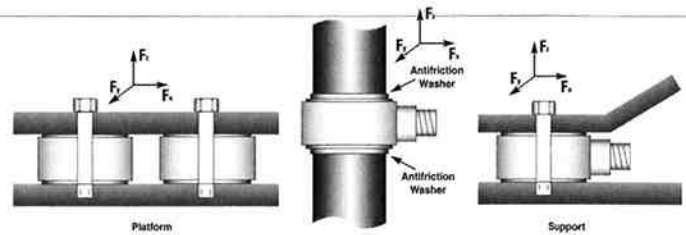

Figure 7 - Series 260A01 to 260A03 ICP® 3-Component Force Sensor

PENETRATION

Penetration style sensors are specifically designed for compression and impact force measurements in materials testing applications. Smooth, cylindrical housings and curved impact caps avoid cutting through specimens permitting yield, deformation, and break point measurements of polymers, composites, and other materials. The axial connector configuration installs into force thruster apparatus and protects the connector from potential damage. Versions offering full-scale measurements of 100 lb to 5,000 lb (444.8 N to 22.24kN) are available. Tension measurements are possible with units having removable caps.

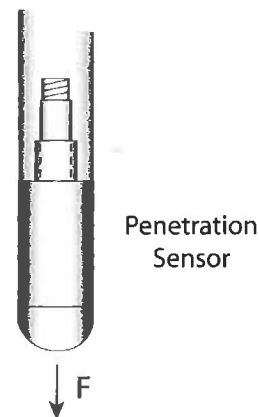

Figure 8 - Series 208A20 ICP® Penetration Force Sensor

MINIATURE/HIGH SENSITIVITY

Series 209 Miniature Sensitivity Sensors permit low amplitude, dynamic compression, tension, and impact force measurements. A full-scale measurement range of 2.2 lbs (9.79 N) compression and 1 lb (4.45 N) tension is standard. Two configurations are available, one with a tapped mounting hole and impact cap, and the other with tapped holes on both ends of the sensor. Link, integrated link, and freestanding installations are possible.

Axial application of forces is critical during measurements due to the sensitivity to bending moments.

NOTE: Due to its highly sensitive characteristic, Series 209 sensors may be susceptible to thermal drift caused by temperature transients. These sensors are recommended for use in temperature stable environments only.

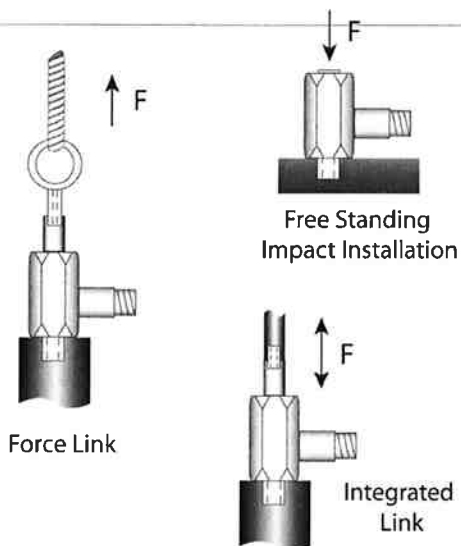

Figure 9 - Series 209 Miniature/High Sensitivity ICP®Force Sensor

3.0 INSTALLATION

CAUTION!
Please read all instructions before attempting to operate this product.

Damage to built-in amplifier due to incorrect power or misapplication is NOT covered by warranty

Refer to the Installation Drawing supplied with this manual for specific outline dimensions and installation details for your particular model. The specification is also included to provide details of the sensor's characteristic properties.

It is important that the surface to which each sensor is mounted be perfectly flat to avoid flexing of the base, which could affect sensor sensitivity and result in erroneous data (see **Figure 10**). A good mating surface may be obtained by lapping, turning, spotfacing, or surface grinding. Surface flatness should be held to within 0.001 (TIR) over the entire mating surface. The protective cap should remain on the connector during installation to prevent contamination or damage.

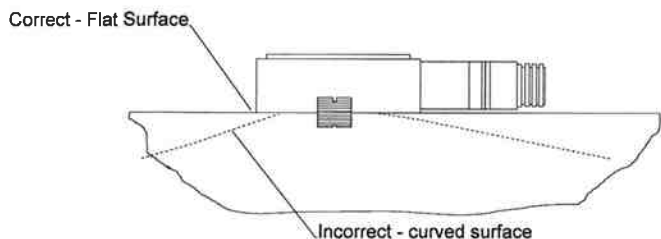

Figure 10 - Force Sensor Installation

A light coating of silicon grease (DC-4 or equivalent) on the mating surface enhances the coupling between the mounting

base and mounting surface and provides the best high-frequency response.

Connect one end of the coaxial cable to the sensor connector and the other end to the XDCR jack on the signal conditioner. Make sure to tighten the cable connector to the sensor. **DO NOT** spin the sensor onto the cable, as this fatigues the cable's center pin, resulting in a shorted signal and a damaged cable.

For installation in dirty, humid, or rugged environments, it is suggested that the connection be shielded against dust or moisture with shrink tubing or other protective material. Strain relieving the cable/sensor connection can also prolong cable life. Mounting cables to a test structure with tape, clamps, or adhesives minimizes cable whip. See **Figure 11** for an example of a sensor installation with a securely fastened cable.

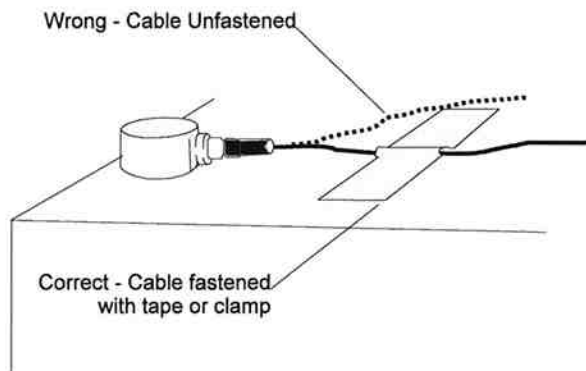

Figure 11 - Cable Strain Relief

FORCE RING INSTALLATION

The sensor is mounted using the supplied mounting stud and pilot bushing. The supplied beryllium copper stud is elastic so it allows force transmission to the sensor while holding the sensor in place. The pilot bushing centers the sensor about the mounting stud. After installing the mounting stud in the lower of the two surfaces, the pilot bushing is threaded over the mounting stud. The sensor is then placed over the stud and pilot bushing combination. The pilot bushing should fit loosely inside of the sensor inner diameter, holding it in place. Properly machined holes for the mounting stud will ensure proper vertical orientation of the sensor. The upper surface should be installed and tightened onto the mounting stud. Refer to the installation drawing for additional mounting details.

When installing the sensor as an integrated member, it is recommended that the supplied antifriction washers be used to eliminate the possibility of damage to the sensing surface of the sensor. This type of damage may occur when imperfections in the mounting surface grind against the sensor surface while the mounting surfaces are being twisted during installation. Refer to the installation drawing for additional mounting details.

PRELOAD REQUIREMENTS FOR FORCE RING AND 3-COMPONENT FORCE SENSORS

PCB ICP® Force Rings (Models 201B01 through 207C) and 3-Component Force Sensors (Models 260A01 through A03) are generally installed between two parts of a test structure, as shown in **Figure 4**. During installation, the sensor should be pre-loaded to the amount specified on the specification sheet using the supplied elastic beryllium-copper stud or customer-supplied bolt. Preloading in this arrangement ensures that the sensor will perform as calibrated and have good output linearity at the sensor's lower operating range.

The stud or bolt holds the structure together and applies preload to the force ring as shown in **Figure 12**. In the typical installation, shown on the left in **Figure 12**, part of the force between the two structures is shunted through the mounting stud. The amount of force shunted may be up to 5% of the total force for the beryllium-copper stud supplied with the sensor and up to 50% for steel studs. This typical installation setup is used by PCB during standard calibrations of force ring models 201B01 through 207C.

Another non-typical installation is shown on the right side of **Figure 12**. In this installation, the stud or bolt used to apply the preload does not shunt part of the applied force. The plate on top of the sensor has a clearance hole that the stud or bolt passes through. In this installation, the stud or bolt is not directly connected to the top plate by its threads, as it is in the typical installation, so it does not shunt any force. This non-typical installation setup is used by PCB during standard calibrations of 3-component sensors. This method of installation accommodates mounting a group of sensors under a common plate.

NOTE: *If any of the following conditions apply to the preloading of the force ring in the actual application, the sensitivity and linearity performance of the sensor will not match the standard PCB calibration values.*

1. *Use of a stud or bolt other than the supplied beryllium-copper stud.*
2. *Use of no stud or bolt.*
3. *Use of an amount of preload other than the recommended amount.*
4. *Use of installation that is different from PCB setup during calibration.*

In these cases, please contact a Force/Torque Division application engineer to discuss your special calibration requirements.

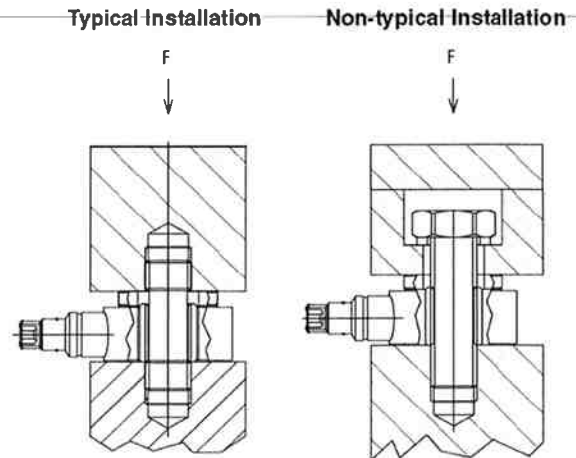

Figure 12 - Force Ring Sensor Installations

PCB in-house calibration procedure requires the installation of a force ring with BeCu stud, in the typical installation setup above, in series with a NIST traceable reference sensor. Generally, a preload of 20% (full scale operating range of the force ring) is applied before recording of measurement data. Contact a PCB application specialist for proper preload requirements. Allow the static component of the signal to discharge before calibration.

3-component force sensors must be preloaded to achieve proper operation, particularly for the shear x-, and y-axis. The recommended applied preload for 3-component force sensors is 10 times their x-axis or y-axis measurement range. Please refer to the specific model specifications for the recommended preload. This preload provides the sensing crystals with the compressive loading required to achieve an output in response to shear direction input forces. As with force rings, the sensitivity achieved from a 3-component force sensor is dependent upon the applied preload and the elasticity characteristics of the mounting bolt or stud used. If the unit is to be installed with a stud or bolt other than the supplied elastic, beryllium copper stud, a calibration using the actual mounting hardware must be preformed. Errors in sensitivity of up to 50% can result by utilizing studs or bolts of different materials.

When installing ICP® ring and 3-component type sensors, a PCB signal conditioner with DC coupling capabilities is recommended to properly monitor sensor output voltage as it corresponds to the desired preload. A DC-coupled signal conditioner will provide a longer system discharge time constant, which will result in slower signal decay. When used with a DVM or similar readout device, the installer can monitor the sensor output voltage directly for correct preloading.

When preloading 3-component type sensors, monitor the output from the Z-axis connector. These sensors require a preload in the Z-axis that is 10 times their shear range. Some models require this to be accomplished in steps, not to exceed the usable voltage. To prevent "clipping" of the signal, increments should not exceed 10 VDC.

Force Ring Models	Pre-Load (lbs)
201B01	60
201B02	100
201B03	200
201B04	400
201B05	1,000
202B	2,000
203B	4,000
204C	8,000
205C	12,000
206C	16,000
207C	33,750
3-Component Models	
260A01	5,000
260A02	10,000
260A03	40,000

Figure 13 - ICP® Force Sensor Preload Requirements

It is necessary to supply the sensor with a 2 to 20 mA constant current at +20 to +30 VDC through a current-regulating diode or equivalent circuit, contained in all PCB signal conditioners. See Guide G-0001B for powering and signal conditioning information pertaining to all ICP® instrumentation.

Most of the signal conditioners manufactured by PCB have an adjustable current feature allowing a choice of input currents from 2 to 20 mA. In general, for lowest noise (best resolution), choose the lower current ranges. When driving long cables (to several thousand feet), use the higher current, up to 20 mA maximum. Consult the factory to determine if higher current settings are required. Connect the sensor to the power unit as shown in the typical ICP® sensor systems below. Operation requires the connection of the force sensor first to a signal conditioner, then to a readout device (oscilloscope, meter, recorder, or A-to-D board) or to a readout device with built-in ICP® sensor excitation. Tighten the coaxial cable to the sensor by hand to ensure good electrical contact. Operation requires the connection of the force sensor first to a signal conditioner, then to a readout device (oscilloscope, meter, recorder, or A-to-D board) or to a readout device with built-in ICP® sensor excitation. Tighten the coaxial cable to the sensor by hand to ensure good electrical contact.

4.0 OPERATION

APPLICATION OF A FORCE

For best results, the applied force should be distributed evenly over the contact surface of the sensor. Care should be taken to limit the bending moment induced into the sensor. This is accomplished by applying a force to the sensor as close as possible to the center of the sensor. It will not be practical to limit this induced bending moment if the sensor is used singularly and if it is mounted beneath a thick plate. In this case, it may be necessary to use an arrangement of two to four sensors in a measuring platform. Independent sensor output can be monitored or the sensors can be connected electrically in parallel to measure the resulting summed forces when used in a plate type arrangement.

TYPICAL ICP® SYSTEM CONFIGURATION

Sensors with built-in ICP® circuitry require a constant-current excitation voltage for operation. The enclosed Specification Sheet provides specific power requirements. Required supply voltage is normally 20 to 30 VDC, while the constant current required ranges from 2 to 20 mA.

PCB standard battery-powered signal conditioners are factory set at 2 mA and may be used to adequately drive a signal for 100 feet. PCB line signal supplies are factory set at 4 mA (and adjustable from 2 to 20 mA), enabling signals to be transmitted over hundreds of feet.

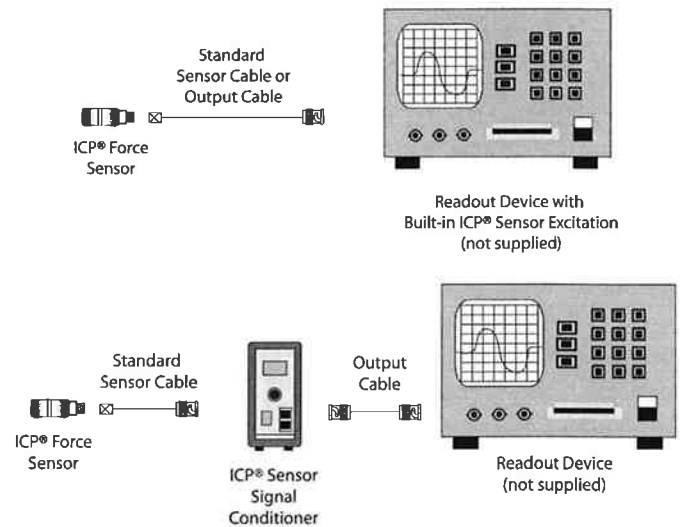

Figure 14 - Typical ICP® System Configurations

5.0 POLARITY

Compressive forces upon an ICP® force sensor produce a positive-going voltage output. Tensile forces produce a negative-going voltage output. Sensors with reversed polarity are available upon request.

6.0 LOW-FREQUENCY MONITORING

Force sensors used for applications in short term, steady state monitoring, such as sensor calibration, or short term, quasistatic testing should be powered by signal conditioners that operate in DC-coupled mode. PCB Series 484 Signal Conditioner operates in either AC or DC-coupled mode and may be supplied with gain features or a zero “clamped” output often necessary in repetitive, positive polarity pulse train applications.

If you wish to learn more about ICP® sensors, consult PCB’s General Signal Conditioning Guide, a brochure outlining the technical specifics associated with piezoelectric sensors. This brochure is available from PCB by request, free of charge.

7.0 DISCHARGE TIME CONSTANT

The discharge time constant (DTC) of the entire transduction system from sensor to readout must be considered when attempting to calibrate an ICP force sensor by static methods. In order to take full advantage of the long DTC built into the force sensor, it is best to DC couple from the sensor to the readout device. Several dual-mode PCB signal conditioners (e.g., Series 484) use direct coupling techniques to decouple the output signal from the sensor bias voltage. With the output of the signal conditioner coupled to a DC readout, such as a digital voltmeter (DVM) or oscilloscope, the time constant of the sensor is not compromised by AC coupling elsewhere in the system.

When DC coupling to a system, it is important to DC couple the entire system and not just from the sensor to the signal conditioner. The system time constant is determined by the shortest time constant in the system. For this reason, the signal conditioner, as well as the readout device, must be DC coupled.

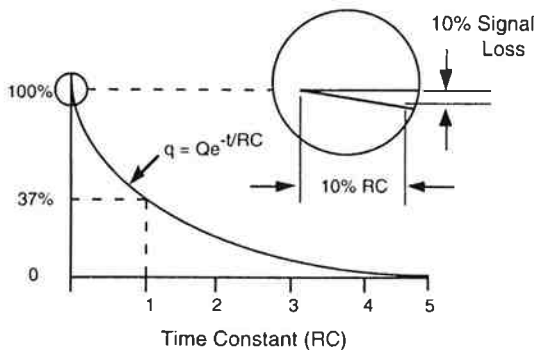

Figure 15 - Characteristic Discharge Time Constant Curve

The discharge time constant represents the decay rate of an input signal. One DTC represents the amount of time taken for the signal to decay to 37% of the initial peak value. As illustrated in Figure 15, this is an exponential decay.

Approximately five DTC intervals are needed for a peak signal to naturally decay back to zero.

The rule of thumb for signal discharge, as outlined in Figure 16, is this: for the first 10% of the DTC, the signal lost is approximately proportional to the time elapsed.

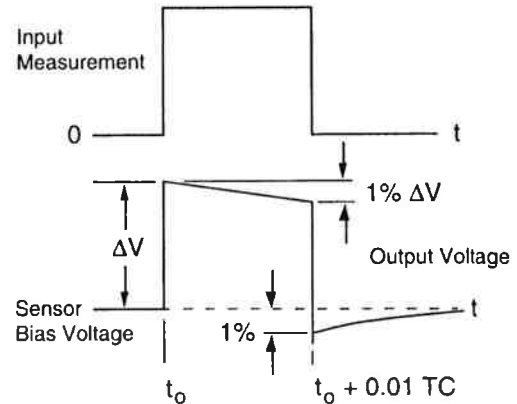

Figure 16 - Step Function Response

Step Function Response

For example, a sensor with a 500-second DTC loses approximately 1% of its output level the first five seconds (1% of 500) after the application of a steady state force within the measuring range. In this case, the output reading must be taken within five seconds of the force application for 1% accuracy. If it is impossible to avoid AC coupling somewhere in the sensing system, try to keep the coupling DTC at least an order of magnitude longer than the DTC of the force sensor. This avoids compromising the sensor DTC.

8.0 CALIBRATION

A NIST (National Institute of Standards and Technology) traceable calibration graph is supplied with each force sensor certifying its voltage sensitivity (mV/lb). Calibration procedures follow accepted guidelines as recommended by ANSI (American National Standards Institute), ISA (Instrument Society of America), and ISO (International Organization for Standardization). These standards provide the establishment and management of complete calibration systems, thus controlling the accuracy of a sensor’s specifications by controlling measuring and test equipment accuracy. PCB is A2LA accredited for technical competence in the field of calibration, meeting the requirements of ISO/IEC 17025-1999 and ANSI/NCSL 2540-1-1994.

9.0 TROUBLESHOOTING

When a PCB signal conditioner with any of the following indicators are used, turn the power on and observe the voltmeter (or LED's) on the front panel.

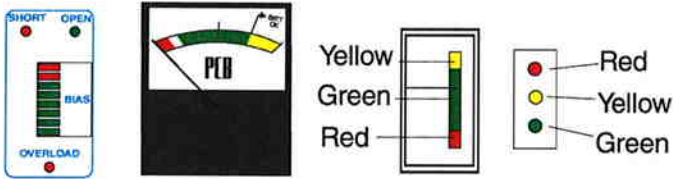

NORMAL OPERATION

INDICATOR	DVM READING	OPERATION
GREEN (Mid-Scale)	8 to 14 V	Proper range for most ICP sensors.
GREEN (Low End)	3 to 7 V	Proper range for low bias ICP sensors.
GREEN (High End)	15 to 17 V	Proper range for high bias ICP sensors.
RED	0 Volts	Short in the sensor, cable, or connections.
YELLOW	24 to 28 V	Open circuit in the sensor, cable, or connections. (Excitation voltage is being monitored.)

Output voltage moves from YELLOW to GREEN slowly until charging is complete. AC coupled signal conditioners require sufficient time to charge the internal coupling capacitor. Allow signal conditioner to charge for after 5 discharge time constants for stable operation.

Note: Most PCB force sensors have an output bias of 8-14 VDC. Refer to the specification sheet in this manual for the bias range of the model you are using. If you are using a low bias sensor, the indicator will be at the bottom end of the green portion of the dial indicator, and may even be in the red portion. This is the expected range and indicates proper operation.

10.0 MAINTENANCE

The sensor connector must be kept clean, especially if it is operating in a dusty and/or wet environment. Because the force sensor is of welded construction, it should be returned to the factory for servicing in the event of serious malfunction.

Observe the following precautions in using the sensor:

- A. Do not exceed the maximum load levels for the force sensor (see specification sheet).
- B. Do not subject the sensor to temperatures exceeding that of the specification, normally 250°F (121°C).
- C. Do not apply voltage to the sensor without current-limiting diodes or other current protection.
- D. Do not apply more than 20 mA of current to the force sensor.
- E. When mounting the force sensor, observe installation procedures detailed in Section 3.0 and as outlined on the specific sensor Installation Drawing to avoid overtorquing when mounting.
- F. Do not apply more than 30 volts to the sensor.
- G. *Avoid metal-to-metal impacts* during applications, which can produce a high-frequency ringing. Electrical low-pass filtering or a damping material can help reduce such effects.
- H. *Do not spin the sensor onto the cable.* This may fatigue the cable center pin, causing cable damage. Always insert the cable pin into the sensor and tighten the knurled cable nut to the sensor.

ICP® is a registered trademark of PCB Piezotronics

Model Number

260A02

3-COMPONENT ICP® FORCE SENSOR

Revision: D

ECN #: 27553

Performance

	ENGLISH	SI	
Sensitivity(± 20 %)(z axis)	2.5 mV/lb	0.56 mV/N	[1][2]
Sensitivity(± 20 %)(x or y axis)	5 mV/lb	1.12 mV/N	[1][2]
Measurement Range(z axis)	1000 lb	4.45 kN	
Measurement Range(x or y axis)	1000 lb	4.45 kN	
Maximum Force(z axis)	1320 lb	5.87 kN	
Maximum Force(x or y axis)	1000 lb	4.45 kN	
Maximum Moment(z axis)	40 ft-lb	54.23 N-m	
Maximum Moment(x or y axis)	70 ft-lb	94.91 N-m	
Broadband Resolution(z axis)	0.006 lb-rms	0.027 N-rms	[3]
Broadband Resolution(x or y axis)	0.006 lb-rms	0.027 N-rms	[3]
Upper Frequency Limit	90 kHz	90 kHz	
Low Frequency Response(-5 %)(z-axis)	0.01 Hz	0.01 Hz	
Low Frequency Response(-5 %)(x or y axis)	0.001 Hz	0.001 Hz	
Non-Linearity	≤ 1 % FS	≤ 1 % FS	[4]
Cross Talk(between x and y axis)	± 3 %	± 3 %	
Cross Talk(between (x or y axis) and z axis)	± 5 %	± 5 %	

Environmental

Temperature Range	-65 to +250 °F	-54 to +121 °C	
-------------------	----------------	----------------	--

Electrical

Full Scale Output(Z Direction)	± 2.5 VDC	± 2.5 VDC	
Full Scale Output(X and Y Direction)	± 5 VDC	± 5 VDC	
Discharge Time Constant(z axis)	≥ 50 sec	≥ 50 sec	
Discharge Time Constant(x or y axis)	≥ 500 sec	≥ 500 sec	
Excitation Voltage(all channels)	20 to 30 VDC	20 to 30 VDC	
Constant Current Excitation(all channels)	2 to 20 mA	2 to 20 mA	
Output Impedance	≤ 100 ohm	≤ 100 ohm	
Output Bias Voltage	8 to 14 VDC	8 to 14 VDC	
Output Polarity	Positive	Positive	

Physical

Preload	10,000 lb	44.48 kN	[5]
Stiffness(z axis)	19 lb/μin	3.3 kN/μm	[3]
Stiffness(x or y axis)	6 lb/μin	1 kN/μm	[3]
Size (Height x Length x Width x Bolt Diameter x ID x Sensing Surface)	0.390 in x 1.35 in x 1.25 in x 0.512 in x 0.512 in x 0.920 in	9.90 mm x 34.3 mm x 31.8 mm x 13 mm x 13 mm x 23.37 mm	
Weight	1.59 oz	45 gm	
Housing Material	Stainless Steel	Stainless Steel	
Sealing	Hermetic	Hermetic	
Electrical Connector	4-Pin	4-Pin	
Electrical Connection Position	Side	Side	

OPTIONAL VERSIONS

Optional versions have identical specifications and accessories as listed for the standard model except where noted below. More than one option may be used.

M - Metric Mount

Supplied Accessory : Model M081A74 Mounting Stud (1) replaces Model 081A74

W - Water Resistant Cable

Electrical Connection Position

Side

Side

NOTES:

[1] Sensitivities are for listed preload. Sensitivities may vary ±5% depending on preload used.

[2] Sensitivities are dependent upon supplied bolt.

[3] Typical.

[4] Zero-based, least-squares, straight line method.

[5] Preload should be at least 10 times the X and Y operating range used.

[6] See PCB Declaration of Conformance PS023 for details.

SUPPLIED ACCESSORIES:

Model 081A74 Pre-load bolt (for Models 260A02, 260A12, and 260A32) (1)

Model 082M12 Anti-friction washer (for Models 260A02, 260A12, and 260A32) (1)

Model 083A13 Pilot bushing (for Models 260A02, 260A12, and 260A32) (1)

Entered: BLS	Engineer: DMB	Sales: PLM	Approved: EF	Spec Number:
Date: 10/23/07	Date: 10/22/07	Date: 10/22/07	Date: 10/22/07	12719



[6]

All specifications are at room temperature unless otherwise specified.

In the interest of constant product improvement, we reserve the right to change specifications without notice.

ICP® is a registered trademark of PCB Group, Inc.

PCB PIEZOTRONICS
FORCE / TORQUE DIVISION
3425 Walden Avenue, Depew, NY 14043

Phone: 716-684-0001

Fax: 716-684-8877

E-Mail: force@pcb.com

12572

PCB Piezotronics Inc. claims proprietary rights in the information disclosed hereon. Neither it nor any reproduction thereof will be disclosed to others without written consent of PCB Piezotronics Inc.

APPLICATION

NEXT ASS'Y	USED ON	VAR

REVISIONS

REV	DESCRIPTION	ECN	DATE	APP'D
D	REVISED PER ECN	15072	3/22/02	<i>DMJ/jr</i>

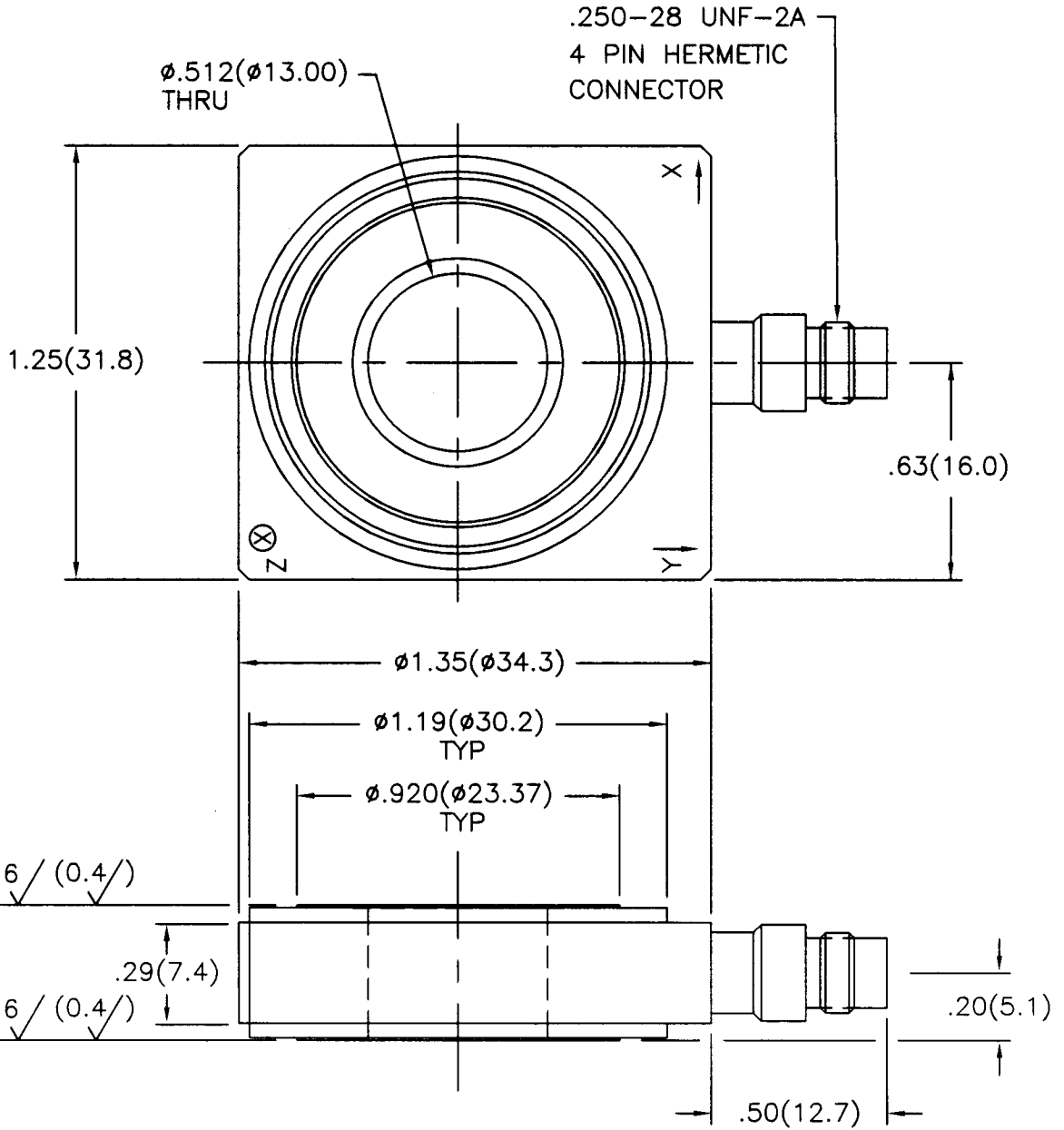

1.) SEE SHEETS 2 AND 3 FOR STANDARD AND METRIC MOUNTING INSTRUCTIONS.

UNLESS SPECIFIED TOLERANCES		DRAWN	<i>.jdm</i>	3-26-02	MFG	<i>JWS</i>	4/6/02	<p>3425 WALDEN AVE. DEPEW, NY 14043 (716) 684-0001 EMAIL: SALES@PCB.COM</p>
DIMENSIONS IN INCHES	DIMENSIONS IN MILLIMETERS (IN PARENTHESIS)	CHK'D	<i>pm</i>	3/24/02	ENGR	<i>KAB</i>	3/26/02	
DECIMALS XX ±.01 XXX ±.005	DECIMALS XX ±0.3 XXX ±0.13	APP'D	<i>myk</i>	3/26/02	SALES	<i>gjm</i>	3/26/02	
ANGLES ±2 DEGREES	ANGLES ±2 DEGREES	TITLE		INSTALLATION DRAWING MODEL (M)260A02 ICP TRIAxIAL FORCE SENSOR		CODE IDENT. NO. 52681	DWG. NO. 12572	
FILLETs AND RADII .003 - .005	FILLETs AND RADII (0.07 - 0.13)	DD007 REV. B 03/13/98		SCALE: 2X		SHEET 1 OF 3		

12572

PCB Piezotronics Inc. claims proprietary rights in the information disclosed hereon. Neither it nor any reproduction thereof will be disclosed to others without written consent of PCB Piezotronics Inc.

APPLICATION

NEXT ASS'Y	USED ON	VAR

REVISIONS

REV	DESCRIPTION	ECN	DATE	APP'D
	-SEE SHEET ONE-			

MODEL 081A74
STUD
1/2-20 UNF-2A
TYP EACH END
(SUPPLIED)

MODEL 083A13
PILOT BUSHING
(SUPPLIED)

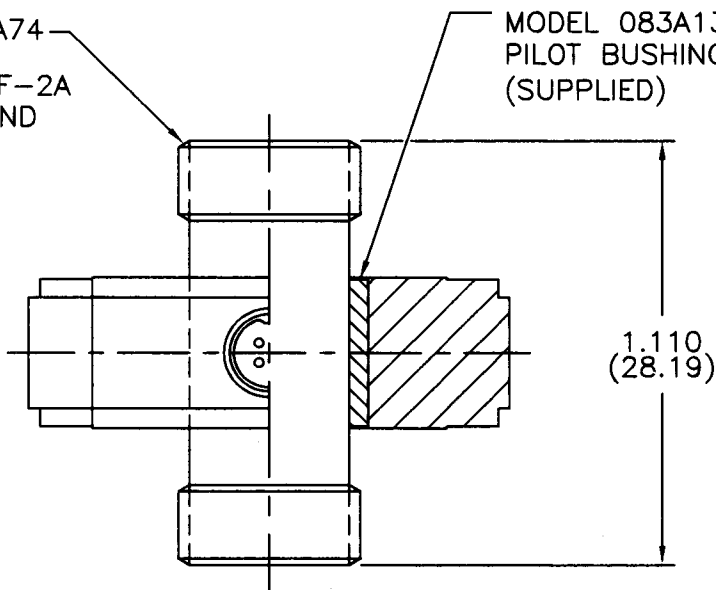

TYP STUD MOUNTING
INSTALLATION

MOUNTING HOLE PREPARATION:

DRILL $\phi .453(\phi 11.51)$ $\triangle 3$
 X .500(12.70) ∇
 TAP 1/2-20 UNF-2B
 X .400(10.16) ∇
 PERFECT THREAD

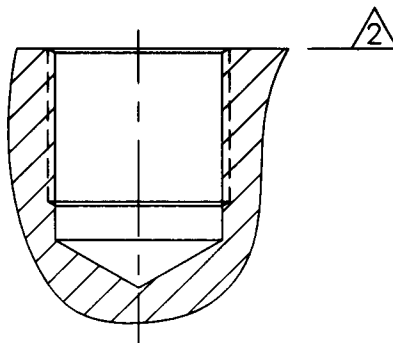

4.) SEE MANUAL FOR PRELOAD INSTRUCTIONS.

$\triangle 3$ DRILL PERPENDICULAR TO MOUNTING SURFACE TO WITHIN $\pm 1^\circ$.

$\triangle 2$ MOUNTING SURFACE UNDER FORCE RING MUST BE FLAT WITHIN .001(0.03) TIR WITH A 32/ (0.8/) FINISH.

UNLESS SPECIFIED TOLERANCES

DIMENSIONS IN INCHES	DIMENSIONS IN MILLIMETERS (IN PARENTHESIS)
DECIMALS XX $\pm .01$ XXX $\pm .005$	DECIMALS XX ± 0.3 XXX ± 0.13
ANGLES ± 2 DEGREES	ANGLES ± 2 DEGREES
FILLETS AND RADII .003 - .005	FILLETS AND RADII (0.07 - 0.13)

DRAWN	JDM	3-26-02	MFG	MS	4/6/02
CHK'D	DM	3/24/02	ENGR	RBR	3/26/02
APP'D	JK	3/26/02	SALES	ggm	3/26/02

PCB PIEZOTRONICS™
 3425 WALDEN AVE. DEPEW, NY 14043
 (716) 684-0001 EMAIL: SALES@PCB.COM

TITLE
 INSTALLATION DRAWING
 MODEL 260A02 ICP
 TRIAXIAL FORCE SENSOR

CODE IDENT. NO. 52681
 DWG. NO. 12572
 SCALE: 2X SHEET 2 OF 3

12572

PCB Piezotronics Inc. claims proprietary rights in the information disclosed hereon. Neither it nor any reproduction thereof will be disclosed to others without written consent of PCB Piezotronics Inc.

APPLICATION

NEXT ASS'Y	USED ON	VAR
------------	---------	-----

REVISIONS

REV	DESCRIPTION	ECN	DATE	APP'D
	-SEE SHEET ONE-			

MODEL M081A74
STUD
M12 X 1.25-6g
TYP EACH END
(SUPPLIED)

MODEL 083A13
PILOT BUSHING
(SUPPLIED)

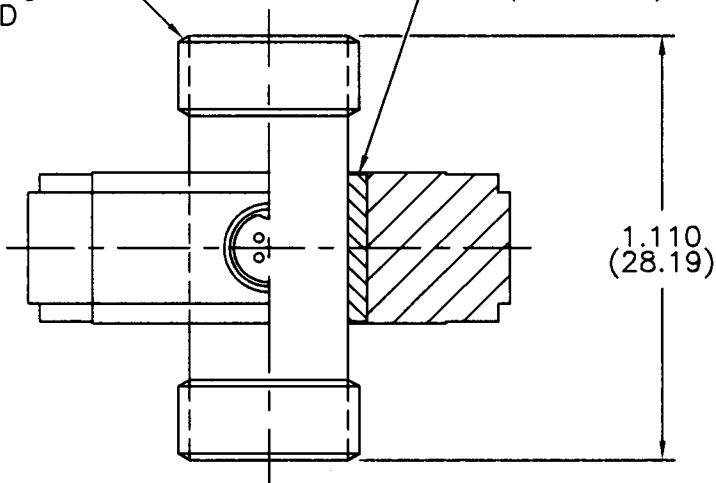

TYP STUD MOUNTING
INSTALLATION

MOUNTING HOLE PREPARATION:

DRILL $\phi .422(\phi 10.80)$ $\triangle 3$
X $.500(12.70)$ ∇
TAP M12 X 1.25-6H
X $.400(10.16)$ ∇
PERFECT THREAD

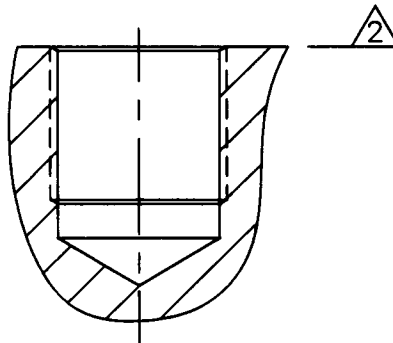

4.) SEE MANUAL FOR PRELOAD INSTRUCTIONS.

$\triangle 3$ DRILL PERPENDICULAR TO MOUNTING SURFACE TO WITHIN $\pm 1^\circ$.

$\triangle 2$ MOUNTING SURFACE UNDER FORCE RING MUST BE FLAT WITHIN $.001(0.03)$ TIR WITH A $32/\sqrt{}$ ($0.8/\sqrt{}$) FINISH.

UNLESS SPECIFIED TOLERANCES

DIMENSIONS IN INCHES	DIMENSIONS IN MILLIMETERS (IN PARENTHESIS)
DECIMALS XX $\pm .01$	DECIMALS XX ± 0.3
XXX $\pm .005$	XXX ± 0.13
ANGLES ± 2 DEGREES	ANGLES ± 2 DEGREES
FILLETS AND RADII .003 - .005	FILLETS AND RADII (0.07 - 0.13)

DRAWN	JDM	4-8-02	MFG	JB5	4/9/02
CHK'D	Am	4/10/02	ENGR	QAR	4/10/02
APP'D	mjk	4/10/02	SALES	gjm	4/10/02
TITLE	INSTALLATION DRAWING MODEL M260A02 ICP TRIAxIAL FORCE SENSOR				

PCB PIEZOTRONICS
3425 WALDEN AVE. DEPEW, NY 14043
(716) 684-0001 EMAIL: SALES@PCB.COM

CODE IDENT. NO. 52681	DWG. NO. 12572
SCALE: 2X	SHEET 3 OF 3