



Model 176M03
Charge Output Pressure Sensor
Installation and Operating Manual

**For assistance with the operation of this product,
contact PCB Piezotronics, Inc.**

Toll-free: 800-828-8840
24-hour SensorLine: 716-684-0001
Fax: 716-684-0987
E-mail: info@pcb.com
Web: www.pcb.com





Service, Repair, and Return Policies and Instructions
--

The information contained in this document supersedes all similar information that may be found elsewhere in this manual.

Service – Due to the sophisticated nature of the sensors and associated instrumentation provided by PCB Piezotronics, user servicing or repair is not recommended and, if attempted, may void the factory warranty. Routine maintenance, such as the cleaning of electrical connectors, housings, and mounting surfaces with solutions and techniques that will not harm the physical material of construction, is acceptable. Caution should be observed to ensure that liquids are not permitted to migrate into devices that are not hermetically sealed. Such devices should only be wiped with a dampened cloth and never submerged or have liquids poured upon them.

Repair – In the event that equipment becomes damaged or ceases to operate, arrangements should be made to return the equipment to PCB Piezotronics for repair. User servicing or repair is not recommended and, if attempted, may void the factory warranty.

Calibration – Routine calibration of sensors and associated instrumentation is recommended as this helps build confidence in measurement accuracy and acquired data. Equipment calibration cycles are typically established by the users own quality regimen. When in doubt about a calibration cycle, a good “rule of thumb” is to recalibrate on an annual basis. It is

also good practice to recalibrate after exposure to any severe temperature extreme, shock, load, or other environmental influence, or prior to any critical test.

PCB Piezotronics maintains an ISO-9001 certified metrology laboratory and offers calibration services, which are accredited by A2LA to ISO/IEC 17025, with full traceability to SI through N.I.S.T. In addition to the normally supplied calibration, special testing is also available, such as: sensitivity at elevated or cryogenic temperatures, phase response, extended high or low frequency response, extended range, leak testing, hydrostatic pressure testing, and others. For information on standard recalibration services or special testing, contact your local PCB Piezotronics distributor, sales representative, or factory customer service representative.

Returning Equipment – *Following these procedures will ensure that your returned materials are handled in the most expedient manner.* Before returning any equipment to PCB Piezotronics, contact your local distributor, sales representative, or factory customer service representative to obtain a Return **Warranty, Service, Repair, and Return Policies and Instructions** Materials Authorization (RMA) Number. This RMA number should be clearly marked on the outside of all package(s) and on the packing

list(s) accompanying the shipment. A detailed account of the nature of the problem(s) being experienced with the equipment should also be included inside the package(s) containing any returned materials.

A Purchase Order, included with the returned materials, will expedite the turn-around of serviced equipment. It is recommended to include authorization on the Purchase Order for PCB to proceed with any repairs, as long as they do not exceed 50% of the replacement cost of the returned item(s). PCB will provide a price quotation or replacement recommendation for any item whose repair costs would exceed 50% of replacement cost, or any item that is not economically feasible to repair. For routine calibration services, the Purchase Order should include authorization to proceed and return at current pricing, which can be obtained from a factory customer service representative.

Contact Information – International customers should direct all inquiries to their local distributor or sales office. A

complete list of distributors and offices can be found at www.pcb.com. Customers within the United States may contact their local sales representative or a factory customer service representative. A complete list of sales representatives can be found at www.pcb.com. Toll-free telephone numbers for a factory customer service representative, in the division responsible for this product, can be found on the title page at the front of this manual. Our ship to address and general contact numbers are:

PCB Piezotronics, Inc.
3425 Walden Ave.
Depew, NY14043 USA
Toll-free: (800) 828-8840
24-hour SensorLineSM: (716) 684-0001
Website: www.pcb.com
E-mail: info@pcb.com



PCB工业监视和测量设备 - 中国RoHS2公布表
 PCB Industrial Monitoring and Measuring Equipment - China RoHS 2 Disclosure Table

部件名称	有害物质					
	铅 (Pb)	汞 (Hg)	镉 (Cd)	六价铬 (Cr(VI))	多溴联苯 (PBB)	多溴二苯醚 (PBDE)
住房	○	○	○	○	○	○
PCB板	X	○	○	○	○	○
电气连接器	○	○	○	○	○	○
压电晶体	X	○	○	○	○	○
环氧	○	○	○	○	○	○
铁氟龙	○	○	○	○	○	○
电子	○	○	○	○	○	○
厚膜基板	○	○	X	○	○	○
电线	○	○	○	○	○	○
电缆	X	○	○	○	○	○
塑料	○	○	○	○	○	○
焊接	X	○	○	○	○	○
铜合金/黄铜	X	○	○	○	○	○
本表格依据 SJ/T 11364 的规定编制。						
○：表示该有害物质在该部件所有均质材料中的含量均在 GB/T 26572 规定的限量要求以下。						
X：表示该有害物质至少在该部件的某一均质材料中的含量超出 GB/T 26572 规定的限量要求。						
铅是欧洲RoHS指令2011/65/ EU附件三和附件四目前由于允许的豁免。						

CHINA RoHS COMPLIANCE

Component Name	Hazardous Substances					
	Lead (Pb)	Mercury (Hg)	Cadmium (Cd)	Chromium VI Compounds (Cr(VI))	Polybrominated Biphenyls (PBB)	Polybrominated Diphenyl Ethers (PBDE)
Housing	O	O	O	O	O	O
PCB Board	X	O	O	O	O	O
Electrical Connectors	O	O	O	O	O	O
Piezoelectric Crystals	X	O	O	O	O	O
Epoxy	O	O	O	O	O	O
Teflon	O	O	O	O	O	O
Electronics	O	O	O	O	O	O
Thick Film Substrate	O	O	X	O	O	O
Wires	O	O	O	O	O	O
Cables	X	O	O	O	O	O
Plastic	O	O	O	O	O	O
Solder	X	O	O	O	O	O
Copper Alloy/Brass	X	O	O	O	O	O

This table is prepared in accordance with the provisions of SJ/T 11364.

O: Indicates that said hazardous substance contained in all of the homogeneous materials for this part is below the limit requirement of GB/T 26572.

X: Indicates that said hazardous substance contained in at least one of the homogeneous materials for this part is above the limit requirement of GB/T 26572.

Lead is present due to allowed exemption in Annex III or Annex IV of the European RoHS Directive 2011/65/EU.

DOCUMENT NUMBER: 21354

DOCUMENT REVISION: **D**

ECN: 46162

1.0 INTRODUCTION

Charge mode pressure sensors offer high performance for precise pressure measurements over a wide range of near-static and dynamic pressures. The sensors use piezoelectric properties to convert an applied pressure into an analogous electrical charge.

The internal design of a sensor incorporates a sensing element that provides high sensitivity over a wide range of pressures. As pressure is applied to the diaphragm of the sensor, a charge is generated in the crystals. The high-impedance electrostatic charge is then conditioned externally by either a laboratory-style charge amplifier or in-line charge converter prior to being sent to a readout or recording device.

Charge mode sensors are ideally suited for applications where wide dynamic range is needed. Such applications include compressors, engines, blast, ballistic, pneumatic, hydraulic, and fluid pressures. Enclosed is a Specification Sheet that lists the complete performance characteristics of the sensor purchased.

2.0 Series 176 High Temperature Differential Output Sensor

The Series 176 High temperature differential output sensor is a special-purpose high temperature charge mode pressure sensor designed specifically to measure low-level pressures in severe environments. The unit is most frequently used in engines, hydraulic and pneumatic devices, compressors and turbines. Ideal for sound pressure measurements, microphones and small pressure agitations, its maximum dynamic pressure range is 100 psi (689 kPa). It is acceleration compensated to minimize vibration sensitivity and is capable of a five-microsecond rise time.

This sensor measures transient or repetitive phenomena relative to the initial or average pressure level, over a wide amplitude range and a usable frequency range near DC to 10 000 Hz; the resonant frequency is 50 000 Hz. The operating temperature for the Series 176 ranges from 0°F to 1000°F. This hermetically sealed sensor contains extremely rigid compression-mode crystals with an integral acceleration compensating crystal to reduce vibration sensitivity and partially suppress internal resonance effects.

Manual Number: 30737
Revision: A
ECR Number: 24690

3.0 Installation

3.1 Overview

When choosing an installation method, the advantages and disadvantages of each method must be carefully weighed. Characteristics like location, ruggedness, amplitude range, accessibility, temperature and portability may be greatly affected by the installation configuration and technique. Often, the most important and overlooked consideration is the affect the mounting technique has on the frequency of the pressure being measured by the sensor.

Two basic mounting techniques are recommended for pressure sensors: the recess mount and the flush mount. The technique used is determined by the specifics of the individual application. See the Installation Drawing in this manual for additional details on the individual sensor series.

3.2 Recess Mount

A recess mount protects the sensor diaphragm from the effect of high flash temperature and particle impingement. This method is often selected because it can prolong sensor life and increase data integrity by reducing thermal effects. See Figure 3.1.

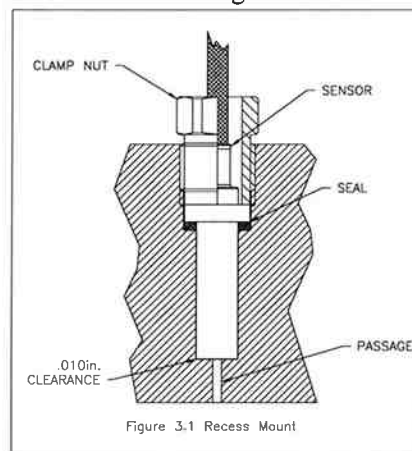

Figure 3.1 Recess Mount

When using a recess mount, note that the length of the passage may limit the frequency range of the measurement. The effect the passage has is similar to that of an under-damped second order system, with the resonant frequency determined by passage length. The passage length thus limits pressure pulse rise time and may also cause passage ringing.

The function is described by the following equation:

$$F_r = \frac{V}{4L}$$

Where: F_r = resonant frequency passage (Hz)
 V = velocity of sound in air (feet/second)
 L = length of column (feet)

For air at room temperature, the equation becomes:

$$F_r = \frac{3300}{L}$$

Where: L = passage length (inches)

The natural frequency and approximately fastest pressure step rise time for various length passages are shown in the following chart, using a medium of air at 77°F (25°C).

Selected Values for 77°F (25°C)

Passage length (inches)	Passage resonance (kHz)	Approx. fastest pulse rise time (microseconds)
.050	66	5
.100	33	10
.200	16.5	20
.50	6.6	50
1.0	3.3	100

Measured resonant frequencies may differ slightly from the chart values due to variations in the velocity of sound in the air from changes in temperature and pressure of the air in the passage.

To ensure diaphragm integrity, maintain .006 inches (.153 mm) of clearance ahead of the diaphragm as shown in Figure 3.1.

3.3 Flush Mount

In a flush mount installation, there is no reduced area passage from the sensor diaphragm to the test chamber. Instead, the sensor diaphragm is mounted flush with, or slightly recessed from, the inside surface of the test chamber. See Figure 3.2.

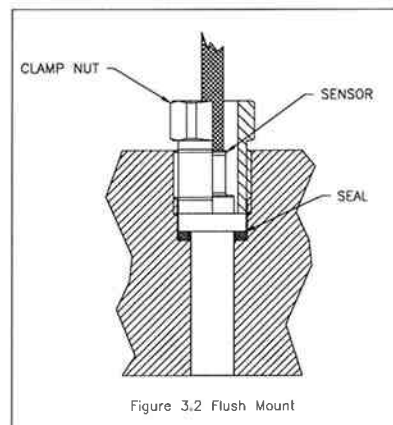

Figure 3.2 Flush Mount

If thermal transients or diaphragm impingement are concerns, use the flush mount technique only when space or frequency response considerations preclude the use of the recess mount installation.

In severe or pyrotechnic environments, sensor life may be seriously curtailed when using this mounting method.

3.4 Cabling

Care and attention to cable attachment is essential, as the reliability and accuracy of your system is no better than that of the output cable. First, check that you have ordered the correct cable type. As with sensors, no cable can satisfy all applications. Special low-noise cabling shielded twisted pair should be used with high-impedance, charge output devices.

Plug the connector on the cable into the mating connector on the sensor. Then, holding the sensor stationary, secure the connector in place by tightening down the attached cable sleeve.

Route the cable to a charge amplifier or in-line charge converter, making certain to strain relieve the sensor/cable connection and minimize motion by clamping the cable at regular intervals. Common sense must be used to avoid physical damage and minimize electrical noise. Avoid routing cables near high voltage wires. Do not route cables along floors or walkways where they may be stepped on or become contaminated. Shielded cable should have the shield grounded at one end only.

To dissipate any charge that may have accumulated in the cable, short the pins to ground prior to attachment to the charge amplifier or charge converter.

4.0 CALIBRATION

These sensors may be calibrated using static hydraulic techniques, such as dead-weight testers, or by comparison with a reference gage.

When calibrating with a laboratory-style charge amplifier, set the charge amplifier to LONG, for the time constant setting, and allow the sensor to stabilize before applying pressure. If slow drift is apparent, apply the pressure to the desired level, and immediately take a reading. Release the pressure and take another reading at zero pressure to obtain the difference between the readings at the desired present level and zero pressure. If the drift is too fast to take a reading, clean the cable connections according to the procedures out-lined in Section 7.0, Maintenance.

NOTE: Do not attempt to use a charge amplifier which, in the long time constant position, has less than a 5 000-second time constant for quasi-static calibration of charge sensors. Any drift may cause error.

A factory-supplied, NIST-traceable calibration graph is provided with each sensor, certifying its charge sensitivity in pC/psi, or when used with an in-line amplifier, in mV/psi.

5.0 Normal Operation

The high impedance signal generated by a charge output sensor is usually conditioned with a laboratory-style charge amplifier. The charge amplifier converts the high-impedance charge signal generated by the sensor into a low-impedance voltage signal. This signal may then be transmitted to a readout or recording device for analysis. See Figure 5.1 for a drawing of a typical system connection.

NOTE: When using charge-amplified systems, the noise floor of the system is dependent on the input capacitance to the charge amplifier. To minimize noise, keep the cable length between the pressure sensor and the charge amplifier to a minimum. Cable length does not affect the system sensitivity.

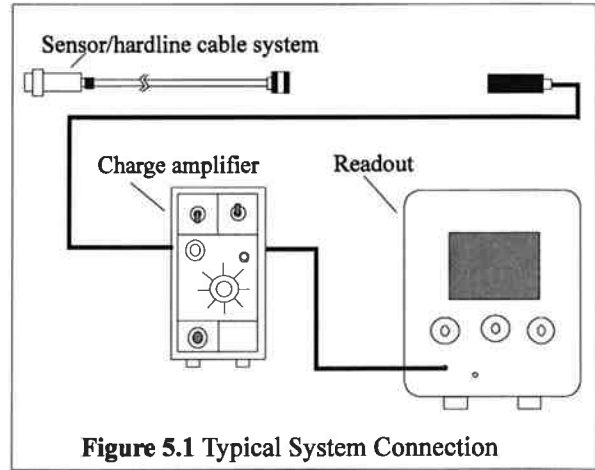

Figure 5.1 Typical System Connection

Before connecting the low-noise cable from the pressure sensor to the charge amplifier, be certain to ground the charge amplifier. This ensures that any excessive accumulated static charges across the sensor/cable combination are harmlessly discharged. If this precaution is not observed, the input FET of certain amplifiers may be destroyed. Press the ground button of the charge amplifier and adjust electrical zero if necessary.

Once system components are connected, wait a few minutes for the system to thermally stabilize. Place the switch in the OPR (operate) position and proceed with the measurement. Refer to the charge amplifier operating manual for further operating details.

For fixed sensitivity in-line charge amplifiers, the system sensitivity (mV/psi) is determined as the product of the charge amplifier sensitivity (mV/pC) and the sensor sensitivity (pC/psi).

6.0 HIGH-TEMPERATURE OPERATION

6.1 Introduction

When subjected to elevated temperature, all piezoelectric sensors/hardline cable systems exhibit decreased insulation resistance, due in part to the piezoelectric element, but due mostly to the hardline cable necessary to withstand the high temperatures. This situation can cause serious voltage offset problems in direct-coupled charge amplifiers. To solve this problem, the user must AC couple (capacitor) the charge amplifier

to the sensor/cable system. See Section 6.3, Solution to Reduced Resistance, for complete details, or use different amplifiers.

6.2 Reduced Resistance at Charge Amplifier Input

Figure 6.1 illustrates a simplified schematic of a typical direct-coupled charge amplifier where:

- R_f = Feedback resistor (ohms)
- R_i = Input leakage resistance (ohms)
- E_o = Steady-state output voltage (volts)
- e_i = Offset voltage: FET leakage (volts)
- C_f = Feedback capacitor (farads)

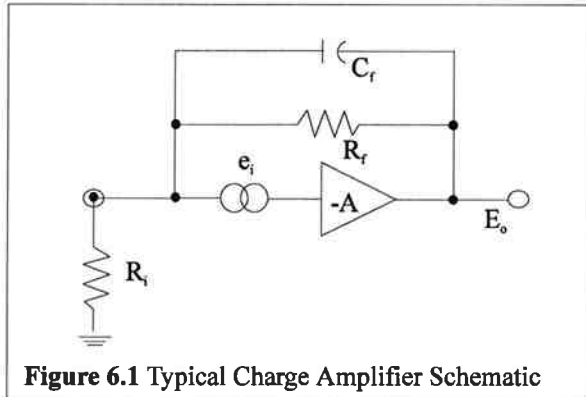

The feedback capacitor C_f comes into play only in the dynamic situation and its influence does not affect the steady-state situation. The voltage e_i is a DC offset voltage, usually very tiny (microvolts), that exists at the input gate of the MOSFET circuit. This minute leakage current exists in all real devices.

As demonstrated in Equation 1, the steady-state (DC) output voltage E_o is:

Equation 1

$$E_o = e_i \left(1 + \frac{R_f}{R_i} \right)$$

This equation shows that if the input (leakage) resistance at the charge amplifier is extremely high (approaching infinity), the output DC voltage approaches e_i , usually a very tiny voltage. However, as R_i decreases, the term

$$1 + \frac{R_f}{R_i}$$

increases, such that the output voltage can, with large ratios of R_f/R_i , become large enough to result in a large E_o , perhaps large enough to be outside the normal output voltage range of the charge amplifier.

Because of the feedback capacitor C_f , this output voltage change usually does not occur rapidly but rather, it manifests itself as a slow drift in the output voltage level. If R_i is low enough with respect to R_f , the voltage drift may continue until saturation of the charge amplifier occurs.

6.3 Solution to Reduced Resistance

Since the drift or offset problem is caused by a static or steady-state imbalance at the input of the charge amplifier, the solution involves blocking this steady-state effect while allowing the desired dynamic phenomena to pass. This may be accomplished by installing a series capacitor at the input of the charge amplifier, between the offending sensor (or low-impedance hardline) and the input.

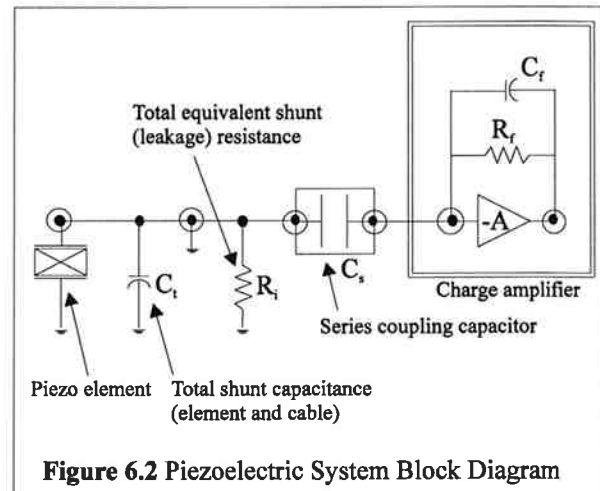

Figure 6.2 illustrates a block diagram of the piezoelectric system where:

- C_1 = Shunt capacitor
- C_s = Series blocking capacitor

With the series blocking capacitor C_s in place as shown, the dynamic charge (Q) generated by the sensor element is distributed across the two capacitors, C_1 and C_s , in proportion to the size (capacitance) of each. If C_s , for example, is equal to 100 times C_1 , 99% of the charge appears at the input of the charge amplifier, while 1% is

across the shunt capacitor C_t . This results in a 1% decrease in apparent sensitivity of the system.

This therefore demonstrates the importance of selecting the series blocking capacitor at least two orders of magnitude higher than the total shunt capacitance C_t across the input of the charge amplifier.

It is also important that this capacitor be of high quality, with a leakage resistance of greater than 10^{12} ohms, to avoid the DC offset discussed previously in 6.1, Introduction.

6.4 Low-Frequency Response Limitations

In a normal charge amplifier, the low-frequency response is set by the RC time constant, as established by the product of C_f and R_f . The system acts like a high-pass first order RC filter with a -3 dB frequency established by the relationship:

Equation 2

$$f_o = \frac{.16}{R_f C_f}$$

where:

f_o = -3 dB Frequency (Hz)
 R_f = Feedback resistor (ohms)
 C_f = Feedback capacitor (farads)

However, after the addition of the series blocking capacitor C_s , the system becomes the equivalent of two high-pass filters in series, one as previously mentioned and one comprised of series capacitor C_s and total equivalent shunt resistance R_i . This new cutoff frequency is:

Equation 3

$$f_o = \frac{.16}{R_i C_s}$$

To avoid compromise of the low-frequency response established by the charge amplifier parameters and illustrated by Equation 2, the product of $R_i C_s$ should be several orders of magnitude higher than $R_f C_f$.

The approximate final system discharge time constant becomes:

Manual Number: 30737
 Revision: A
 ECR Number: 24690

Equation 4a

$$TC = \frac{1}{\frac{1}{R_i C_s} + \frac{1}{R_f C_f}} \quad \text{seconds}$$

If the input coupling time constant ($R_i C_s$) is very much greater than the discharge time constant of the charge amplifier ($R_f C_f$), Equation 4a then becomes:

Equation 4b

$$\frac{1}{R_i C_s} \Rightarrow 0 \text{ Seconds}$$

Equation 5

$$TC = R_f C_f$$

With the product $R_i C_s$ chosen to be much greater than $R_f C_f$, the system discharge time constant is simply $R_f C_f$ (seconds). The feedback parameters of the charge amplifier establish the low frequency characteristics of the system, unaffected by the degraded input resistance parameters of the test sensor and/or cable.

6.5 Other Precautions

Always remember to keep the OPR-GND switch on the charge amplifier in the GND position while connecting or disconnecting sensors, cable, or capacitor to the input connector. Stray or accumulated electrostatic charges may build to the point that they may saturate or even damage the input circuitry of the charge amplifier.

Operate the charge amplifier in the SHORT time constant while the sensor is subject to elevated or changing temperatures.

If it is not necessary to procure data during the transition from room temperature to operating temperature, place the OPR-GND switch in the GND position to keep spurious, thermally generated charges grounded.

It is prudent to momentarily switch to the GND position even during the measurement period to ensure that excess charges do not accumulate at the input of the charge amplifier.

7.0 MAINTENANCE

The only maintenance required on the pressure sensor is to keep the connector clean. If it is operating in a dirty environment, protect the cable connections with heat-shrink tubing or similar material.

In the event that the electrical connection of the pressure sensor becomes contaminated with dirt or moisture, the insulation resistance degrades. This may cause a reduction of sensitivity or excessive drifting when connected to the charge amplifier. If this happens, brush off the connector with no-residue solvent or other approved cleaning solutions. To restore insulation, bake the sensor in a vacuum oven at 250°F for about four hours. If the condition persists even after cleaning and/or baking, please contact a PCB applications engineer for further assistance. The sensor is hermetically sealed; it must therefore be returned to the factory if the aforementioned measures fail to restore performance.



СЕРТИФИКАТ СООТВЕТСТВИЯ

№ ТС RU C-US.ГБ05.B.00365

Серия RU № 0083143

ОРГАН ПО СЕРТИФИКАЦИИ НАНИО "Центр по сертификации взрывозащищенного и рудничного электрооборудования". 115230, Москва, Электрولитный проезд, д. 1, корп. 4, комната № 9 (юридический); РФ, 140004, Московская обл., г. Люберцы, ВУГИ, ОАО "Завод "ЭКОМАШ" (фактический), тел. /факс: +7 (495) 554-2494, E-mail: zalogin@ccve.ru. Аттестат (рег. № РОСС RU.0001.11ГБ05) выдан 09.08.2011 Федеральным агентством по техническому регулированию и метрологии. Приказ об аккредитации Федеральной службы по аккредитации № 2860 от 13.08.2012

ЗАЯВИТЕЛЬ Общество с ограниченной ответственностью «ВиброСпектр»,
Юридический адрес: РФ, 119048, Москва, ул. Усачева, д. 35, стр. 1;
Фактический адрес: РФ, 111538, Москва, ул. Косинская, д. 7. ОГРН: 1047796909929.
Телефон: (499) 374-58-45; факс: (499) 374-59-52. E-mail: info@vibraspectrum.ru.

ИЗГОТОВИТЕЛЬ PCB Piezotronics, Inc.,
IMI Sensors, 3425 Walden Av., Depew, NY 14043, США.

ПРОДУКЦИЯ Пьезоэлектрические преобразователи вибрации EX**6**+**, 351M*, EX357*, 355*, EX611xxx/xxxx, EX600XXX; давления 1xxAuуу, 1xxVuуу, 1xxMuуу, вибровыключатели 685B*, 685A08, 686B*, усилитель заряда EX682XYYY с маркировкой взрывозащиты согласно приложению (см. бланки №№ 0066670, 0066661, 0066662, 0066663). Серийный выпуск.

КОД ТН ВЭД ТС 9031 80 380 0

СООТВЕТСТВУЕТ ТРЕБОВАНИЯМ Технического регламента Таможенного союза ТР ТС 012/2011 «О безопасности оборудования для работы во взрывоопасных средах»; Стандартам согласно приложению, см. бланк № 0066659.

СЕРТИФИКАТ ВЫДАН НА ОСНОВАНИИ Протокола испытаний № 21.2014-Г от 30.01.2014 ИЛ ЦСВЭ (рег. № РОСС RU.0001.21ГБ04, срок действия с 05.08.2011 по 21.10.2014); Акта о результатах анализа состояния производства № 145-А/13 от 08.11.2013 ОС ЦСВЭ (рег. № РОСС RU.0001.11ГБ05, срок действия с 09.08.2011 по 28.07.2015).

ДОПОЛНИТЕЛЬНАЯ ИНФОРМАЦИЯ Схема сертификации 1с.
Сертификат действителен с приложением на 5-ти листах.
Инспекционный контроль – 2015 г., 2016 г., 2017 г., 2018 г.

СРОК ДЕЙСТВИЯ С 31.01.2014 ПО 31.01.2019 ВКЛЮЧИТЕЛЬНО



М.П.

Руководитель (уполномоченное лицо) органа по сертификации

Эксперт (эксперт-аудитор)
(эксперты (эксперты-аудиторы))

(подпись)
(подпись)

А.С. Залогин
(инициалы, фамилия)Б. А. Рафалович
(инициалы, фамилия)

ПРИЛОЖЕНИЕ

К СЕРТИФИКАТУ СООТВЕТСТВИЯ №ТС RU C-US.ГБ05.В.00365 Лист 1

Серия RU № 0066659

Сведения о стандартах, применяемых на добровольной основе для соблюдения требований технического регламента Таможенного союза ТР ТС 012/2011 «О безопасности оборудования для работы во взрывоопасных средах»

Обозначение стандартов	Наименование стандартов
ГОСТ Р 51330.0-99 (МЭК 60079-0-98)	Электрооборудование взрывозащищенное. Часть 0. Общие требования.
ГОСТ 30852.0-2002 (МЭК 60079-0:1998)	Электрооборудование взрывозащищенное. Часть 0. Общие требования.
ГОСТ Р 51330.1-99 (МЭК 60079-1-98)	Электрооборудование взрывозащищенное. Часть 1. Взрывозащита вида «взрывонепроницаемая оболочка».
ГОСТ 30852.1-2002 (МЭК 60079-1:1998)	Электрооборудование взрывозащищенное. Часть 1. Взрывозащита вида «взрывонепроницаемая оболочка».
ГОСТ Р 51330.10-99 (МЭК 60079-11-99)	Электрооборудование взрывозащищенное. Часть 11. Искробезопасная электрическая цепь <i>i</i> .
ГОСТ 30852.10-2002 (МЭК 60079-11:1999)	Электрооборудование взрывозащищенное. Часть 11. Искробезопасная электрическая цепь <i>i</i> .
ГОСТ Р 51330.14-99	Электрооборудование взрывозащищенное. Часть 15. Защита вида <i>n</i>
ГОСТ 30852.14-2002	Электрооборудование взрывозащищенное. Часть 15. Защита вида <i>n</i>



М.П.

Руководитель (уполномоченное
лицо) органа по сертификации

Эксперт (эксперт-аудитор)
(эксперты (эксперты-аудиторы))

(подпись)

А.С. Залогин

(инициалы, фамилия)

(подпись)

Б.А. Рафалович

(инициалы, фамилия)

ПРИЛОЖЕНИЕ

К СЕРТИФИКАТУ СООТВЕТСТВИЯ №ТС RU C-US.ГБ05.В.00365 Лист 2

Серия RU № 0066670

1. НАЗНАЧЕНИЕ И ОБЛАСТЬ ПРИМЕНЕНИЯ

Пьезоэлектрические преобразователи вибрации EX**6**+**, 351M*, EX357*, 355*, EX611xxx/xxxx, EX600XXX; давления 1xxAyyy, 1xxVyyy, 1xxMyyy (далее – преобразователи), вибровыключатели 685B*, 685AX8, 686B* (далее – вибровыключатели) и усилители заряда EX682XYYY предназначены для контроля, параметров вибрации, динамического давления и преобразования их в электрический сигнал.

Область применения - взрывоопасные зоны помещений и наружных установок согласно маркировке взрывозащиты.

2. ОСНОВНЫЕ ТЕХНИЧЕСКИЕ ДАННЫЕ ИЗДЕЛИЙ

2.1. Маркировка взрывозащиты:		0ExialICT4 X
- преобразователей EX**6**+**, 351M*, 355*		0ExialICT4...T6 X
- преобразователей 355*		0ExialICT4 X или 0ExialICT1 X или 2ExnL ICT4 X или 2ExnLICT1 X
- преобразователей EX357*		0ExialICT6...T710 X
- преобразователей EX611xxx/xxxx		0ExialICT4 X 0ExialICT1 X
- преобразователей EX600XXX: усилителя заряда сенсора и кабеля		0ExialICT4 X или 2ExnLICT4 X или 0ExialICT4...T1 X или 2ExnA ICT4...T1 X
- преобразователей 1xxAyyy, 1xxVyyy, 1xxMyyy,		
- вибровыключателей:		1ExdIIB + H ₂ T4 1ExdICT6 1ExdIIBT6 2ExnLICT3 X или 2ExnAICT3 X 1ExdICT3
- 685		
- 685B0X01C14		
- 685AX8		
- 686B*		
- EX**686		
- усилителей заряда EX682XYYY		0ExialICT4 X или 2ExnAICT4 X
2.2. Степень защиты от внешних воздействий по ГОСТ 14254-96, не ниже:		IP65
- преобразователей и вибровыключателей		IP20
- усилителей заряда EX682XYYY по ГОСТ 14254-96		
2.4. Температура окружающей среды, °C, для преобразователей:		от -40 до +121 от -40 до +80 от -40 до +100
- EX602Dxx, EX603Cxx, EX606Bxx, EX607Axx, EX608Axx;		
- EX64... , EXTO64... , EXRV64...;		
- EX649A0x, EX649A1x, EX649A6x, EX649A7x;		
- EX622A01, EX622A11, EX622A31, EX628F01, EX628F11, EX628F31, EXVO622A01, EXVO622A11, EXVO622A31, EX623C00, EX623C01, 351M*, 1xxAyyy, 1xxVyyy, 1xxMyyy;		от -54 до +121 от 0 до +121 от 0 до +121 от 0 до +450 от 0 до +135 от -54 до +135 от -54 до +450 от -54 до +13 от -196 до +700 от -51 до +121 от -54 до +440
- 105xyyy, 175xyyy;		
- 176Myyy с маркировкой 2ExnLICT1 X;		
- 176Myyy с маркировкой 2ExnLICT4 X;		
- EX357* с маркировкой 0ExialICT4 X		
- EX357* с маркировкой 0ExialICT1 X		
- 355*		
- EX611xxx/xxxx		
- усилителя заряда преобразователей EX600XXX		
- сенсора и кабеля преобразователей EX600XXX		
для вибровыключателей:		
- 685B*, 685A08		от -40 до +60 от -35 до +85 от -40 до +85
- 686B*		
для усилителей заряда EX682XYYY		



М.П.

Руководитель (уполномоченное
лицо) органа по сертификации

Эксперт (эксперт-аудитор)
(эксперты (эксперты-аудиторы))

(подпись)

А.С. Залогин

(инициалы, фамилия)

(подпись)

Б.А. Рафалович

(инициалы, фамилия)

62912 REV. NR
ECO 44160
11/24/15

ПРИЛОЖЕНИЕ

К СЕРТИФИКАТУ СООТВЕТСТВИЯ №ТС RU C-US.ГБ05.В.00365 Лист 3

Серия RU № 0066661

2.5. Входные искробезопасные электрические параметры преобразователей вибрации:

Модель	Напряжение U_i , В	Ток I_i , мА	Мощность P_i , Вт	Емкость C_i , нФ	Индуктивность, мкГн
EX602Dxx, EX603Cxx, EX606Bxx, EX607Axx, EX608Axx	28	200	1	16,2 – 77,2	0 - 305
EX64xB0y	30	100	1	0	1,06
EX64xB1y	30	100	1	61	306
EXTO64xB3y	28	120	1	0	1,06
EXTO64xB1y, EXTO64xB6y	28	120	1	61	306
EXRV64xB0y	28	120	1	0	121,06
EXRV64xB1y EXRV64xB6y	28	120	1	61	426
EX64xB7y	30	100	1	0	1,06
EXTO64xB7y	28	120	1	0	1,06
EXRV64xB7y	28	120	1	0	1,06
EX64xA0y	30	100	1	0	1,06
EX64xA1y	30	100	1	61	306
EXRV64xA1y EXRV64xA6y	30	100	1	61	306
EXTO64xA1y EXTO64xA6y	28	120	1	61	306
EXRV64xA0y	28	120	1	0	121,06
EXRV64xA1y EXRV64xA6y	28	120	1	61	426
351M*	28	200	1,2	0	0
EX357*	30	100	1	1,4	0
355*	30	100	1	72	0
EX611xxx/xxxx	30	100	0,7	3,3	30
EX600XXX	28	120	1	0	0

2.6. Входные искробезопасные электрические параметры преобразователей давления:

Модель	Напряжение U_i , В	Ток I_i , мА	Мощность P_i , Вт	Емкость C_i , нФ	Индуктивность, мкГн
105хууу	24	150	1	100	20
175хууу	24	150	1	100	20
176Мууу	30	100	1	5	500
102Мууу	30	200	1	5	0

2.7. Электрические параметры вибровыключателей:

EX686B0x	30
- напряжение, U_i , В, не более	100
- ток, I_i , мА, не более	1
- мощность, P_i , Вт, не более	28
- индуктивность, L_i , мкГн, не более	0
- емкость, C_i , нФ, не более	
EX686B1y, EX686B6y	30
- напряжение, U_i , В, не более	100
- ток, I_i , мА, не более	1
- мощность, P_i , Вт, не более	333
- индуктивность, L_i , мкГн, не более	61
- емкость, C_i , нФ, не более	
EX686B7x	240/500
- напряжение /ток, В/мА, не более	



Руководитель (уполномоченное
лицо) органа по сертификации

Эксперт (эксперт-аудитор)
(эксперты (эксперты-аудиторы))

(подпись)
(подпись)

А.С. Залогин
(инициалы, фамилия)

Б.А. Рафалович
(инициалы, фамилия)

ПРИЛОЖЕНИЕ

К СЕРТИФИКАТУ СООТВЕТСТВИЯ № TC RU C-US.ГБ05.В.00365 Лист 4

Серия RU № 0066662

685B0X01C14		
- напряжение питания переменного тока/ток, В/мА, не более		245/150
- напряжение питания постоянного тока/ток, В/мА, не более		24/150
- выходной токовый сигнал, В/мА		15/4-20
- коммутируемое напряжение переменного тока/ток, В/А		245/10
- коммутируемое напряжение постоянного тока /ток, В/А		30/5
685AX8		
- коммутируемое напряжение переменного тока/ток, В/А		480/5
- коммутируемое напряжение постоянного тока /ток, В/А		30/2

3. ОПИСАНИЕ КОНСТРУКЦИИ И СРЕДСТВ ОБЕСПЕЧЕНИЯ ВЗРЫВОЗАЩИЩЕННОСТИ

Преобразователи состоят из пьезоэлектрического чувствительного элемента и усилительно-преобразующей платы, которые залиты высокотемпературным герметиком и установлены в корпусе из нержавеющей стали. На наружной поверхности корпуса нанесена маркировка.

Преобразователи EX600XXX состоят из пьезоэлектрического сенсора, соединенного бронированным кабелем длиной до 10 м с усилителем заряда, выполненным в стальном корпусе. Металлическая броня кабеля приварена к корпусам сенсора и усилителя заряда.

Преобразователи могут быть выполнены с постоянно закрепленным кабелем с герметичным разъемом на свободном конце или с установленным на корпусе герметичным разъемом.

Вибровыключатели выполнены во взрывозащищенных оболочках, в качестве которых применены цилиндрические или прямоугольные корпуса, закрытые крышкой со стопорным винтом типа 2HKB-B-2GLD производства фирмы Killaré или типа XJSHX-N4 производства фирмы Adalet или типа SA090907 производства фирмы Cortem, и предназначены для непосредственного монтажа на контролируемом оборудовании. Внутри корпуса установлен пьезоэлектрический акселерометр, электронный блок и клеммные зажимы для подключения внешних электрических цепей. На боковых поверхностях корпуса расположены резьбовое отверстие под кабельный ввод, механический регулятор чувствительности, кнопка обнуления и заземляющий зажим. На крышке закреплена табличка с маркировкой.

Усилители заряда EX682XYYY выполнены в унифицированном пластмассовом корпусе, в котором расположены печатные платы с элементами электронной схемы. На торцах верхней поверхности корпуса расположены клеммные зажимы для подключения входных и выходных цепей. На боковой поверхности нанесена заводская табличка с маркировкой взрывозащиты. Усилители заряда EX682XYYY устанавливаются на DIN-рейку в электротехническом шкафу, обеспечивающего степень защиты от внешних воздействий не менее IP 54.

Взрывозащищенность преобразователей обеспечивается видом взрывозащиты "Искробезопасная электрическая цепь i " по ГОСТ Р 51330.10-99 (МЭК 60079-11-99), ГОСТ 30852.10-2002 (МЭК 60079-11:1999) или защитой вида «nL» (преобразователей 176Мууу) по ГОСТ Р 51330.14-99, ГОСТ 30852.14-2002 а также выполнением их конструкции в соответствии с требованиями ГОСТ Р 51330.0-99 (МЭК 60079-0-98), ГОСТ 30852.0-2002 (МЭК 60079-0:1998).

Взрывозащищенность вибровыключателей 685B*, 685A08 обеспечивается видом взрывозащиты "взрывонепроницаемая оболочка" по ГОСТ Р 51330.1-99 (МЭК 60079-1-98), ГОСТ 30852.1-2002 (МЭК 60079-1:1998) и выполнением их конструкции в соответствии с требованиями ГОСТ Р 51330.0-99 (МЭК 60079-0-98), ГОСТ 30852.0-2002 (МЭК 60079-0:1998).

Взрывозащищенность вибровыключателей 686B* обеспечивается видом взрывозащиты защитой вида "nA" или «nL» по ГОСТ Р 51330.14-99, ГОСТ 30852.14-2002 и выполнением их конструкции в соответствии с требованиями ГОСТ Р 51330.0-99 (МЭК 60079-0-98), ГОСТ 30852.0-2002 (МЭК 60079-0:1998).

Взрывозащищенность усилителей заряда EX682XYYY обеспечивается видом взрывозащиты "Искробезопасная электрическая цепь i " по ГОСТ Р 51330.10-99 (МЭК 60079-11-99), ГОСТ 30852.10-2002 (МЭК 60079-11:1999) или защитой вида «nL» по ГОСТ Р 51330.14-99, ГОСТ 30852.14-2002, а также выполнением их конструкции в соответствии с требованиями ГОСТ Р 51330.0-99 (МЭК 60079-0-98), ГОСТ 30852.0-2002 (МЭК 60079-0:1998).

4. МАРКИРОВКА

Маркировка, наносимая на преобразователи, вибровыключатели и усилители заряда, должна включать следующие данные:

- товарный знак или наименование предприятия - изготовителя;
- тип изделия;
- заводской номер и год выпуска;
- маркировку взрывозащиты;
- специальный знак взрывобезопасности;
- диапазон температур окружающей среды;
- наименование или знак центра по сертификации и номер сертификата,
- и другие данные, требуемые нормативной и технической документацией, которые изготовитель должен отразить в маркировке.



М.П.

Руководитель (уполномоченное
лицо) органа по сертификацииЭксперт (эксперт-аудитор)
(эксперты (эксперты-аудиторы))

(подпись)

А.С. Залогин
(инициалы, фамилия)

(подпись)

Б.А. Рафалович
(инициалы, фамилия)

ПРИЛОЖЕНИЕ

К СЕРТИФИКАТУ СООТВЕТСТВИЯ № TC RU C-US.ГБ05.В.00365 Лист 5

Серия RU № 0066663

5. СПЕЦИАЛЬНЫЕ УСЛОВИЯ ЭКСПЛУАТАЦИИ, ОБОЗНАЧЕННЫЕ ЗНАКОМ X

Знак X, стоящий после маркировки взрывозащиты, означает, что при эксплуатации преобразователей необходимо соблюдать следующие "специальные" условия:

- преобразователи с искробезопасными входными цепями должны подключаться ко вторичной аппаратуре с выходными искробезопасными цепями уровня "ia", сертифицированной в установленном порядке для подключения устройств, находящихся во взрывоопасных зонах помещений и наружных установок, где возможно образование взрывоопасной газовой смеси категории IIC;
- искробезопасные параметры выходных цепей вторичной аппаратуры, с учетом параметров соединительного кабеля, должны соответствовать входным искробезопасным параметрам преобразователей (п.п. 2.5 – 2.7);
- усилители заряда EX682XYUY должны устанавливаться в электротехническом шкафу, обеспечивающем степень защиты от внешних воздействий не менее IP 54.
- зависимость температурного класса от температуры окружающей среды для преобразователей вибрации 355*:
T6 для $T_a \leq +80$ °C;
T5 для $T_a \leq +95$ °C;
T4 для $T_a \leq +130$ °C.

Специальные условия эксплуатации, обозначенные знаком X, должны быть отражены в сопроводительной документации, подлежащей обязательной поставке в комплекте с каждым изделием.



М.П.

Руководитель (уполномоченное
лицо) органа по сертификации

Эксперт (эксперт-аудитор)
(эксперты (эксперты-аудиторы))

(подпись)

А.С. Залогин

(инициалы, фамилия)

(подпись)

Б.А. Рафалович

(инициалы, фамилия)

PCB Piezotronics Inc. claims proprietary rights in the information disclosed hereon. Neither it nor any reproduction thereof will be disclosed to others without the written consent of PCB Piezotronics Inc.

REVISIONS

REV	DESCRIPTION	DIN
A	UPDATE T CODES	44160

57723

SCHEDULE DRAWING

NO MODIFICATIONS PERMITTED WITHOUT REFERENCE TO THE NOTIFIED BODY

ENTITY PARAMETER

- Ui = 30V
- li = 300 mA
- Pi = 1W
- C(ELEMENT)=1000pF(MAX)
- C(HARDLINE)= 4000pF(MAX)
- L(ELEMENT)=0μH
- L(HARDLINE)= 500μH(MAX)
- Ci = C(ELEMENT)+C(HARDLINE)
- Li = L(ELEMENT)+L(HARDLINE)
- Ci ≤ 5000 pF
- Li ≤ 500 μH

HAZARDOUS LOCATION

- Cl. 1, Div. 2, Gp. A,B,C,D
- Cl. 1, Zn. 2, AEx nA/Ex nA IIC
- T6 to T660°C
- T6 to T530°C

- T1: Ta<440°C
- T2: Ta<290°C
- T3: Ta<195°C
- T4: Ta<130°C
- T5: Ta<95°C
- T6: Ta<80°C
- T660°C: Ta<650°C
- T530°C: Ta<520°C

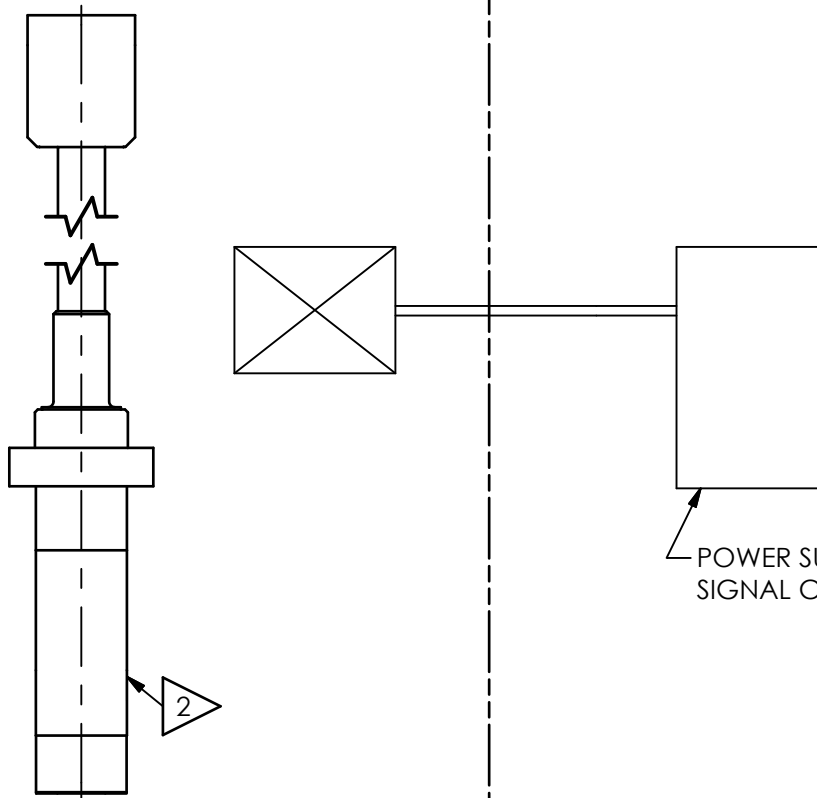

NON HAZARDOUS LOCATION

- 5.) FIELD WIRING MUST BE 26 AWG MINIMUM.
- 4.) HARDLINE CABLE 200 [61 m] FEET MAX.
- 3.) FOR CANADIAN, DIVISION 2 ZONE 2 INSTALLATION, POWER SUPPLY MUST BE CSA CERTIFIED WITH ENTITY OUTPUT PARAMETERS. FOR U.S., DIVISION 2 AND ZONE 2 INSTALLATION, POWER SUPPLY MUST BE APPROVED BY NRTL WITH ENTITY OUTPUT PARAMETERS.

2 PHYSICAL CHARACTERISTICS(DIMENSIONS,ETC) MAY NOT BE ACCURATELY REPRESENTED

- 1.) MAXIMUM VOLTAGE OF POWER SUPPLY/SIGNAL CONDITIONER NEVER TO EXCEED 250 Vrms.

UNLESS OTHERWISE SPECIFIED	
DIMENSIONS ARE IN INCHES	
DECIMALS	X ± .05
	XX ± .01
	XXX ± .005
	XXXX ± .0005
ANGLES ± 2 DEGREES	
FILLETS AND RADII .003 - .005	
HEX DIMENSIONS ARE:	
	≤ .5 + .000 / - .003
	> .5 + .000 / - .005
INTERNAL THREAD DEPTH MIN.	
REMOVE ALL BURRS	
SHARP = R.000 - R.003	

DRAWN		CHECKED		ENGINEER	
BB	11/18/15	ECB	11/18/15	EDB	11/18/15
TITLE					
SPECIFICATION CONTROL DRAWING					

PCB PIEZOTRONICS™
 3425 WALDEN AVE. DEPEW, NY 14043
 (716) 684-0002 E-MAIL: sales@pcb.com

CODE IDENT. NO. 52681	DWG. NO. 57723
SCALE: NONE	SHEET 1 OF 2

PCB Piezotronics Inc. claims proprietary rights in the information disclosed hereon. Neither it nor any reproduction thereof will be disclosed to others without the written consent of PCB Piezotronics Inc.

REVISIONS

REV	DESCRIPTION	DIN
	-SEE SHEET 1-	

57723

SCHEDULE DRAWING

NO MODIFICATIONS PERMITTED WITHOUT REFERENCE TO THE NOTIFIED BODY

ENTITY PARAMETER

- U_i = 30V
- i_i = 300 mA
- P_i = 1W
- C(ELEMENT)=1000pF(MAX)
- C(HARDLINE)= 4000pF(MAX)
- L(ELEMENT)=0μH
- L(HARDLINE)= 500μH(MAX)
- C_i = C(ELEMENT)+C(HARDLINE)
- L_i = L(ELEMENT)+L(HARDLINE)
- C_i ≤ 5000 pF
- L_i ≤ 500 μH

HAZARDOUS LOCATION

Cl. 1, Div. 1, Gp. A,B,C,D
Cl. 1, Zn. 0, AEx/Ex ia IIC

T6 to T660°C
T6 to T530°C

- T1: T_a<440°C
- T2: T_a<290°C
- T3: T_a<195°C
- T4: T_a<130°C
- T5: T_a<95°C
- T6: T_a<80°C
- T660°C: T_a<650°C
- T530°C: T_a<520°C

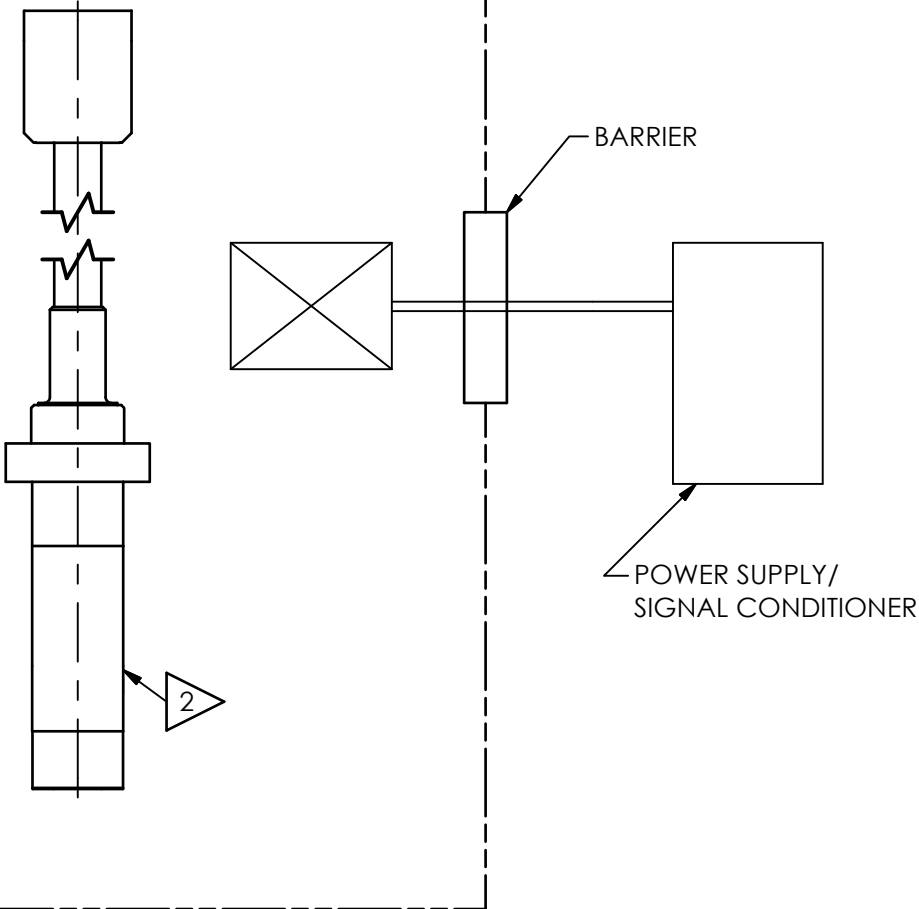

NON HAZARDOUS LOCATION

- 5.) FIELD WIRING MUST BE 26 AWG MINIMUM.
- 4.) HARDLINE CABLE 200 [61 m] FEET MAX.
- 3.) FOR CANADIAN, DIVISION 1 ZONE 0 INSTALLATION, POWER SUPPLY MUST BE CSA CERTIFIED WITH ENTITY OUTPUT PARAMETERS.
FOR U.S., DIVISION 1 AND ZONE 0 INSTALLATION, POWER SUPPLY MUST BE APPROVED BY NRTL WITH ENTITY OUTPUT PARAMETERS.

2) PHYSICAL CHARACTERISTICS(DIMENSIONS,ETC) MAY NOT BE ACCURATELY REPRESENTED

1.) MAXIMUM VOLTAGE OF POWER SUPPLY/SIGNAL CONDITIONER NEVER TO EXCEED 250 Vrms.

UNLESS OTHERWISE SPECIFIED	
DIMENSIONS ARE IN INCHES	
DECIMALS	X ± .05
	XX ± .01
	XXX ± .005
	XXXX ± .0005
ANGLES ± 2 DEGREES	
FILLETS AND RADII .003 - .005	
HEX DIMENSIONS ARE:	
	≤ .5 + .000 / - .003
	> .5 + .000 / - .005
INTERNAL THREAD DEPTH MIN.	
REMOVE ALL BURRS	
SHARP = R.000 - R.003	

DRAWN		CHECKED		ENGINEER	
BB	11/18/15	ECB	11/18/15	EDB	11/18/15
TITLE					
SPECIFICATION CONTROL DRAWING					

PCB PIEZOTRONICS
 3425 WALDEN AVE. DEPEW, NY 14043
 (716) 684-0002 E-MAIL: sales@pcb.com

CODE IDENT. NO. 52681	DWG. NO. 57723
SCALE: NONE	SHEET 2 OF 2

Model Number 176M03	CHARGE OUTPUT PRESSURE SENSOR	Revision: K ECN #: 46623
-------------------------------	--------------------------------------	-----------------------------

	ENGLISH	SI	
Performance			
Sensitivity(± 20 %)	17 pC/psi	247 pC/bar	
Measurement Range	20 psi	1.4 bar	
Maximum Pressure(Total)	400 psi	27.6 bar	
Resonant Frequency	>50 kHz	>50 kHz	
Transverse Resonance	≥ 5 kHz	≥ 5 kHz	
Frequency Response	10 kHz	10 kHz	[2][3]
Non-Linearity	≤ 1 % FS	≤ 1 % FS	[4]
Environmental			
Acceleration Sensitivity	≤ 0.01 psi/g	≤ .00069 bar/g	
Temperature Range(Continuous)	-94 to 986 °F	-70 to 530 °C	
Temperature Range(Receptacle)	-76 to 500 °F	-60 to 260 °C	
Temperature Response	See Graph	See Graph	[1]
Hazardous Area Approval	See Manual	See Manual	
Radiation Exposure Limit(Integrated Gamma Flux)	1E8 rad	1E8 rad	
Radiation Exposure Limit(Integrated Neutron Flux)	1E10 N/cm ²	1E10 N/cm ²	
Electrical			
Output Polarity(Differential)	Differential	Differential	
Capacitance(with cable pin - pin)	<165 pF	<165 pF	
Internal Resistance(room temp)	≥ 10 ¹² Ohm	≥ 10 ¹² Ohm	
Insulation Resistance(room temp)	≥ 10 ¹² Ohm	≥ 10 ¹² Ohm	
Internal Resistance(986°F/530°C)	≥ 50 kohm	≥ 50 kohm	
Insulation Resistance(986°F/530°C)	≥ 100 kohm	≥ 100 kohm	
Physical			
Sensing Element	UHT-12™	UHT-12™	
Sensing Geometry	Compression	Compression	
Housing Material	Nickel Alloy	Nickel Alloy	
Sealing	Welded Hermetic	Welded Hermetic	
Electrical Connector	7/16-27 2-Pin	7/16-27 2-Pin	
Cable Type	Overbraided Hardline	Overbraided Hardline	
Weight(with clamp nut & cable)	4.9 oz	140 gm	

OPTIONAL VERSIONS

Optional versions have identical specifications and accessories as listed for the standard model except where noted below. More than one option may be used.

NOTES:

[1] Typical.
 [2] Low frequency response is determined by external signal conditioning electronics.
 [3] Upper frequency response is calculated from Resonant Frequency.
 [4] Zero-based, least-squares, straight line method.
 [5] See PCB Declaration of Conformance PS058 for details.

SUPPLIED ACCESSORIES:

Model 30498-01 Clamp nut (1)
 Model 40890-01 Silver plated, ss, seal (6)

Typical Sensitivity Deviation vs Temperature

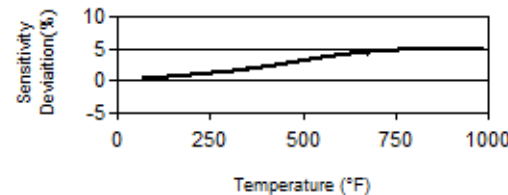

All specifications are at room temperature unless otherwise specified.
 In the interest of constant product improvement, we reserve the right to change specifications without notice.
 ICP® is a registered trademark of PCB Group, Inc.

Entered: LK	Engineer: GJR	Sales: JC	Approved: BAM	Spec Number:
Date: 3/30/2017	Date: 3/30/2017	Date: 3/30/2017	Date: 3/30/2017	35041

3425 Walden Avenue, Depew, NY 14043

Phone: 716-684-0001
Fax: 716-684-0987
E-Mail: info@pcb.com

54210

PCB Piezotronics Inc. claims proprietary rights in the information disclosed hereon. Neither it nor any reproduction thereof will be disclosed to others without the written consent of PCB Piezotronics Inc.

SCHEDULE DRAWING
NO MODIFICATIONS PERMITTED WITHOUT REFERENCE TO THE NOTIFIED BODY

REVISIONS		
REV	DESCRIPTION	DIN
B	UPDATED NOTES	44160

- 5.) INSTALL PER EN/IEC 60079-14 AND ALL LOCAL ELECTRICAL LAWS.
- 4.) MODEL NUMBER 176XYY/MZZZ-AA CERTIFICATE LCIE 08 ATEX 6102X.
MODEL NUMBER 176XYY/MZZZ-AA CERTIFICATE IECEX LCIE 12.0025X.
- 3.) SHIELDS TO BE EARTHED AT BARRIER ENDS.

2 BARRIER WILL BE MOUNTED IN AN ENCLOSURE THE SUITABILITY OF WHICH WILL BE DETERMINED BY LOCAL AUTHORITIES.

1 ENTITY APPLICATION

<u>BARRIER</u>	<u>I.S. APPARATUS</u>
$V_{oc}/U_o \leq V_{max} / U_i$	
$I_{sc}/I_o \leq I_{max} / I_i$	
$C_a/C_o > C_i + C_{cable}$	
$L_a/L_o > L_i + L_{cable}$	
$P_o \leq P_i$ (CENELEC ONLY)	

BARRIERS WITHIN THE SPECIFIED LIMITATIONS ARE PERMITTED

ENTITY PARAMETERS

OPTION 1
 $U_i = 30V$
 $I_i = 300\text{ mA}$
 $P_i = 1\text{ W}$
 $C_i = 5\text{ nF}$
 $L_i = 500\text{ }\mu\text{H}$

CERTIFIED BY THE APPROPRIATE APPROVAL AUTHORITY FOR CONNECTION TO THE FOLLOWING AREAS:

- ZONE 0
- Ex ia IIC Ga
- $T_a \leq 650^\circ\text{C}$ T660°C*
- $T_a \leq 520^\circ\text{C}$ T530°C*
- $T_a \leq 440^\circ\text{C}$ T1
- $T_a \leq 290^\circ\text{C}$ T2
- $T_a \leq 195^\circ\text{C}$ T3
- $T_a \leq 130^\circ\text{C}$ T4
- $T_a \leq 95^\circ\text{C}$ T5
- $T_a \leq 80^\circ\text{C}$ T6

*REFERENCE ETCHING ON SENSOR FOR MAXIMUM AMBIENT TEMPERATURE AND ASSOCIATED TEMPERATURE CLASS.

NOTES: C_i IS SPECIFIED AT A MAXIMUM CABLE LENGTH OF 200 FT. [61 METERS] FOR SHORTER CABLE LENGTHS, C_i IS DECREASED BY 20 pF/FT. [65.6 pF/METER.]

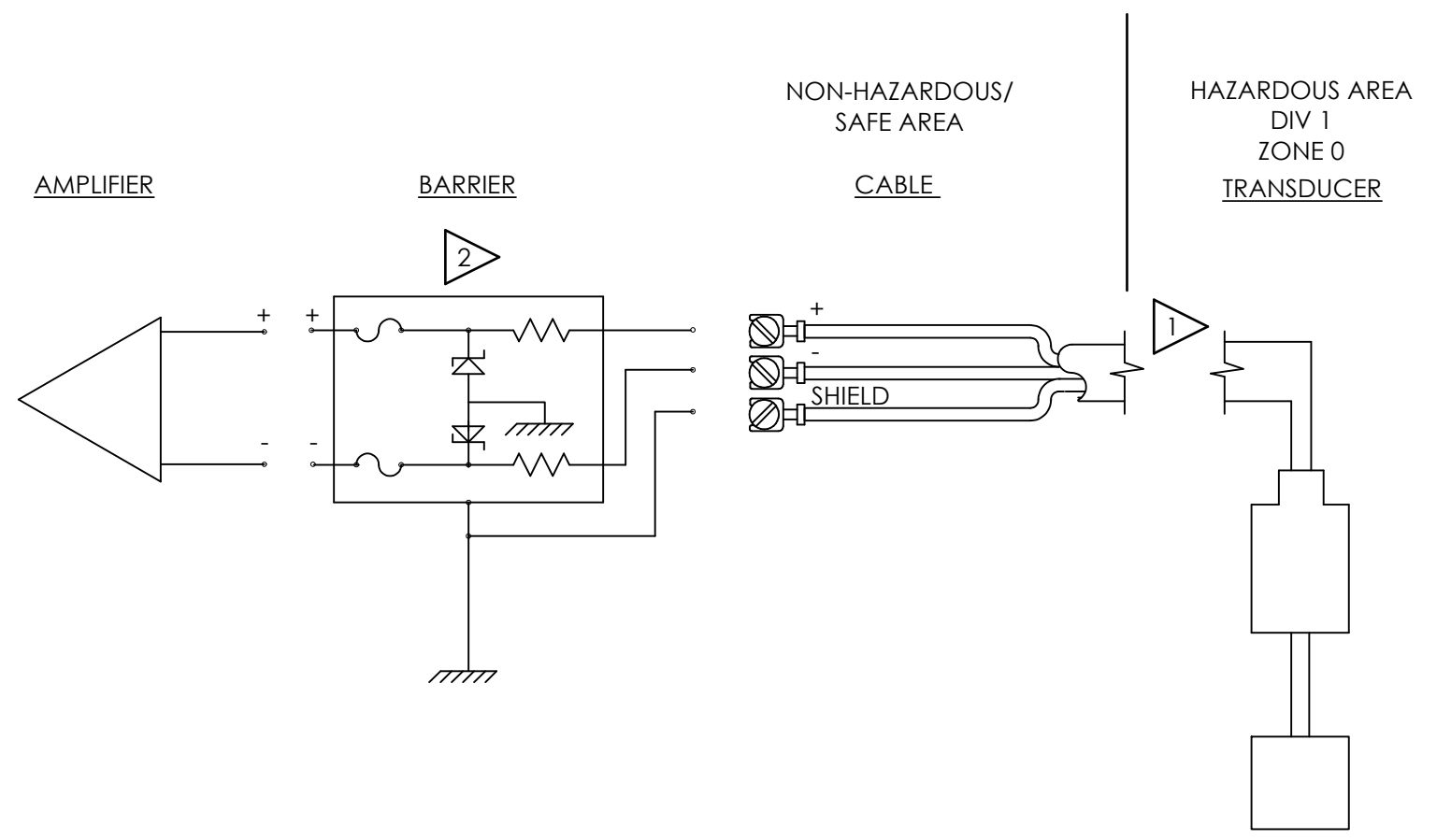

UNLESS OTHERWISE SPECIFIED	
DIMENSIONS ARE IN INCHES	
DECIMALS	X ± .05
	XX ± .01
	XXX ± .005
	XXXX ± .0005
ANGLES ± 2 DEGREES	
FILLETS AND RADII .003 - .005	
HEX DIMENSIONS ARE:	
	≤ .5 + .000 / - .003
	> .5 + .000 / - .005
INTERNAL THREAD DEPTH MIN.	
REMOVE ALL BURRS	
SHARP = R.000 - R.003	



DRAWN		CHECKED		ENGINEER	
BB	11/18/15	ECB	11/18/15	EDB	11/18/15
TITLE					
APPROVAL INTERCONNECTION					

PCB PIEZOTRONICS™
 3425 WALDEN AVE. DEPEW, NY 14043
 (716) 684-0002 E-MAIL: sales@pcb.com

CODE IDENT. NO. 52681	DWG. NO. 54210
SCALE: NONE	SHEET 1 OF 2

54210

PCB Piezotronics Inc. claims proprietary rights in the information disclosed hereon. Neither it nor any reproduction thereof will be disclosed to others without the written consent of PCB Piezotronics Inc.

SCHEDULE DRAWING
NO MODIFICATIONS PERMITTED WITHOUT REFERENCE TO THE NOTIFIED BODY

REVISIONS		
REV	DESCRIPTION	DIN
	-SEE SHEET 1-	

NON-HAZARDOUS/ SAFE AREA
OR DIV 2/ ZONE 2

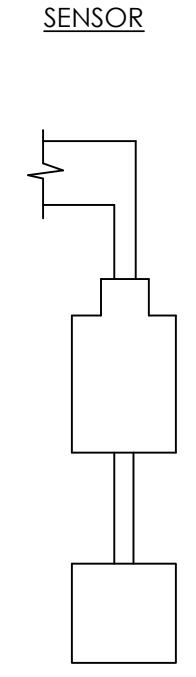
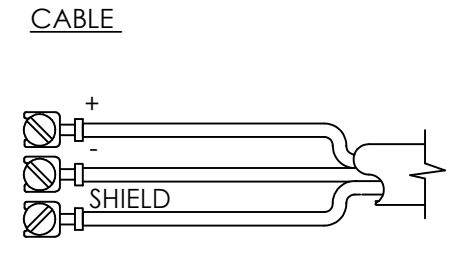
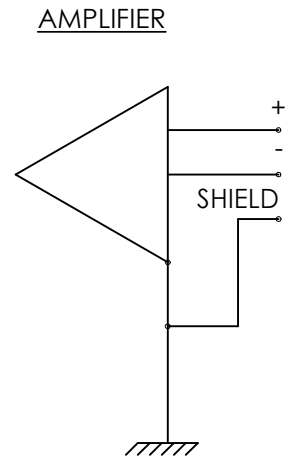

- 5.) INSTALL PER EN/IEC 60079-14 AND ALL LOCAL ELECTRICAL LAWS.
 - 4.) MODEL NUMBER 176XYY/MZZZ-AA CERTIFICATE LCIE 06 ATEX 6041X.
MODEL NUMBER 176XYY/MZZZ-AA CERTIFICATE IECEx LCIE 12.0026X.
 - 3.) FOR ZONE 2 INSTALLATION, POWER SUPPLY MUST BE CERTIFIED WITH ENTITY OUTPUT PARAMETERS (SEE PAGE 1 FOR POWER SUPPLY OUTPUT PARAMETERS.)
 - 2.) MAXIMUM VOLTAGE OF POWER SUPPLY/SIGNAL CONDITIONER NEVER TO EXCEED 250 Vrms.
 - 1.) CERTIFIED BY THE APPROPRIATE APPROVAL AUTHORITY FOR CONNECTION TO THE FOLLOWING AREAS:
ZONE 2
Ex nA IIC Gc
Ta ≤ 650°C T660°C*
Ta ≤ 520°C T530°C*
Ta ≤ 440°C T1
Ta ≤ 290°C T2
Ta ≤ 195°C T3
Ta ≤ 130°C T4
Ta ≤ 95°C T5
Ta ≤ 80°C T6
*REFERENCE ETCHING ON SENSOR FOR MAXIMUM AMBIENT TEMPERATURE AND ASSOCIATED TEMPERATURE CLASS.
- DIV 2
CLASS I, GROUPS A,B,C,D

UNLESS OTHERWISE SPECIFIED	
DIMENSIONS ARE IN INCHES	
DECIMALS	X ± .05
	XX ± .01
	XXX ± .005
	XXXX ± .0005
ANGLES ± 2 DEGREES	
FILLETS AND RADII .003 - .005	
HEX DIMENSIONS ARE:	
	≤ .5 + .000 / - .003
	> .5 + .000 / - .005
INTERNAL THREAD DEPTH MIN.	
REMOVE ALL BURRS	
SHARP = R.000 - R.003	



DRAWN		CHECKED		ENGINEER	
BB	11/18/15	ECB	11/18/15	EDB	11/18/15
TITLE					
APPROVAL INTERCONNECTION					

PCB PIEZOTRONICS™
3425 WALDEN AVE. DEPEW, NY 14043
(716) 684-0002 E-MAIL: sales@pcb.com

CODE IDENT. NO. 52681	DWG. NO. 54210
SCALE: NONE	SHEET 2 OF 2

ATEX Approved Sensors Pressure Sensors (Models 176 Series)

English

This sensor has been approved for Hazardous Locations Directive 94/9/EC, Ex ia IIC Ga and Ex nA IIC Gc, T6 to T530°C/T660°C.

For safe use:

- All applicable local electrical laws must be followed
- The supply electrical parameters must not exceed any of the following values:
 - o $U_o \leq 30V$, $I_o \leq 300mA$, $P_o \leq 1W$, $C \leq 5nF$, $L \leq 500\mu H$
- Ambient operating temperature range:
 - o $-70^\circ C$ to $+520^\circ C$ or $-70^\circ C$ to $+650^\circ C$

Deutsch

Dieser ist genehmigt worden für Gefährliche Orte Direktive 94/9/EC, Ex ia IIC Ga und Ex nA IIC Gc, T6 to T530°C/T660°C.

Für sicheren Gebrauch:

- Alle zutreffenden örtlichen elektrischen Gesetze müssen gefolgt werden
- Die Versorgung elektrische Parameter müssen kein von den Folgenden Werten überschreiten:
 - o $U_o \leq 30V$, $I_o \leq 300mA$, $P_o \leq 1W$, $C \leq 5nF$, $L \leq 500\mu H$
- Umgebungsbedienungs-temperaturbereich:
 - o $-70^\circ C$ to $+520^\circ C$ or $-70^\circ C$ to $+650^\circ C$

Français

Ce détecteur a été approuvé pour les Emplacements Hasardeux Directif 94/9/EC, Ex ia IIC Ga et Ex nA IIC Gc, T6 to T530°C/T660°C.

Pour l'usage sûr :

- Toutes lois électriques, locales et applicables doivent être suivies
- La provision les paramètres électriques ne doivent pas dépasser n'importe quel des valeurs suivantes :
 - o $U_o \leq 30V$, $I_o \leq 300mA$, $P_o \leq 1W$, $C \leq 5nF$, $L \leq 500\mu H$
- La gamme de température d'opération Ambiante :
 - o $-70^\circ C$ to $+520^\circ C$ or $-70^\circ C$ to $+650^\circ C$

Italiano

Questo sensore è stato approvato per le Posizioni Pericolose Direttivo 94/9/EC, Ex ia IIC Ga ed Ex nA IIC Gc, T6 to T530°C/T660°C.

Per l'uso sicuro:

- Tutte le leggi applicabili, locali elettriche devono essere seguite
- La provvista i parametri elettrici non devono eccedere qualunque dei valori seguenti: seguenti:
 - o $U_o \leq 30V$, $I_o \leq 300mA$, $P_o \leq 1W$, $C \leq 5nF$, $L \leq 500\mu H$
- la gamma di temperatura di funzionamento di Ambiente:
 - o $-70^\circ C$ to $+520^\circ C$ or $-70^\circ C$ to $+650^\circ C$

Español

Este sensor se ha aprobado para Ubicaciones Peligrosas Directivas 94/9/EC, Ex ia IIC Ga y Ex nA IIC Gc, T6 to T530°C/T660°C.

Para el uso seguro:

- Todas leyes eléctricas, locales y aplicables se deben seguir
- El suministro los parámetros eléctricos no deben exceder cualquiera de los siguientes valores:
 - o $U_o \leq 30V$, $I_o \leq 300mA$, $P_o \leq 1W$, $C \leq 5nF$, $L \leq 500\mu H$
- El Ambiente que opera la gama de la temperatura:
 - o $-70^\circ C$ to $+520^\circ C$ or $-70^\circ C$ to $+650^\circ C$

Русский

Этот датчик был одобрен для Опасной Директивы 94/9/EC Местоположений, Ex ia IIC Ga и Ex nA IIC Gc, T6 to T530°C/T660°C.

Для безопасного использования:

- Все применимые местные электрические законы должны сопровождаться
- Поставка электрические параметры не должна превысить ни одной из следующих ценностей:
 - o $U_o \leq 30V$, $I_o \leq 300mA$, $P_o \leq 1W$, $C \leq 5nF$, $L \leq 500\mu H$
- Окружающий операционный температурный диапазон:
 - o $-70^\circ C$ to $+520^\circ C$ or $-70^\circ C$ to $+650^\circ C$

Drawing Number: 35030

Revision: **G**

ECN Number: 45606

Norsk

Denne sensoren godkjenner for Farlige Plasseringer Direktiv 94/9/EC, Ex ia IIC Ga og Ex nA IIC Gc, T6 to T530°C/T660°C.

For sikker bruk:

- Alle anvendelige lokale elektriske lover fulgt
- Forsyningen elektriske parametre må ikke overskride noe av de følgende verdiene:
 - o $U_o \leq 30V$, $I_o \leq 300mA$, $P_o \leq 1W$, $C \leq 5nF$, $L \leq 500\mu H$
- Omgivende betjeningsav temperaturrekkevidde:
 - o **-70°C** to +520°C or **-70°C** to +650°C

Nederlands

Deze sensor is goedgekeurd voor gevaarlijke locaties Richtlijn 94/9 / EG Ex ia IIC Ga en Ex nA IIC Gc , T6 to T530°C / T660°C .

Voor veilige gebruik:

- Alle toepasbare plaatselijke elektrische wetten moeten gevolgd worden
- De aanbod elektrische parameters moeten de volgende waarde niet overschrijden:
 - o $U_o \leq 30V$, $I_o \leq 300mA$, $P_o \leq 1W$, $C \leq 5nF$, $L \leq 500\mu H$
- Het omgevend bediening temperatuur bereik:
 - o **-70°C** to +520°C or **-70°C** to +650°C

Português

Este sensor foi aprovado para a Diretiva 94/9/EC de Posições Arriscada, Ex ia IIC Ga e Ex nA IIC Gc, T6 to T530°C/T660°C.

Para uso seguro:

- Todas as leis elétricas locais aplicáveis devem ser seguidas
- O estoque parâmetros elétricos não devem exceder qualquer dos seguintes valores:
 - o $U_o \leq 30V$, $I_o \leq 300mA$, $P_o \leq 1W$, $C \leq 5nF$, $L \leq 500\mu H$
- Variedade de temperatura operacional ambiente:
 - o **-70°C** to +520°C or **-70°C** to +650°C

Svensk

Den här sensoren er blitt gillat för Riskabel Lokaliseringarna Direktiv 94/9/ EC Ex ia IIC Ga och Ex nA IIC Gc, T6 to T530°C/T660°C.

För kassaskåp använda :

- All användbar lokal elektrisk lag måste bli följde efter
- Tillförselen som elektriska parametrar inte måste överskrida några av värderar efter:
 - o $U_o \leq 30V$, $I_o \leq 300mA$, $P_o \leq 1W$, $C \leq 5nF$, $L \leq 500\mu H$
- Omgivande opera- temperatur ställa i rad :
 - o **-70°C** to +520°C or **-70°C** to +650°C

Drawing Number: 35030

Revision: **G**

ECN Number: 45606

31375

PCB Piezotronics Inc. claims proprietary rights in the information disclosed hereon. Neither it nor any reproduction thereof will be disclosed to others without the written consent of PCB Piezotronics Inc.

RELATED DRAWING
NO MODIFICATIONS PERMITTED WITHOUT THE APPROVAL OF THE AUTHORIZED PERSON

REVISIONS		
REV	DESCRIPTION	DIN
H	ADDED HEX TO CABLE ADAPTOR	44160

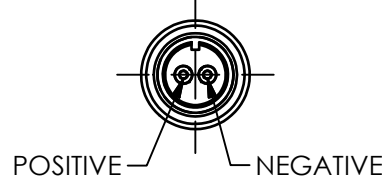
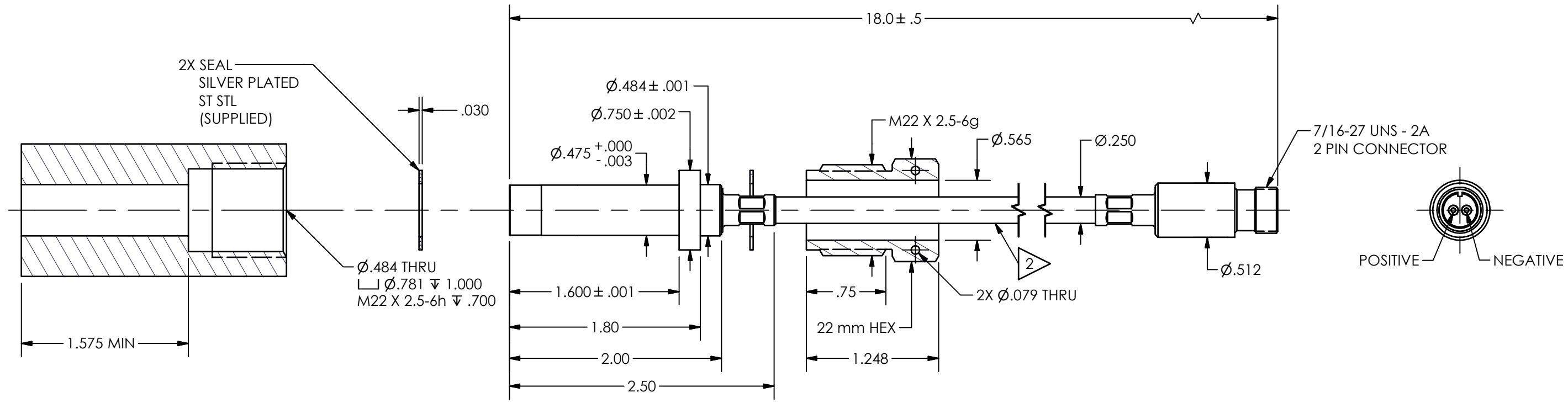

2 MINIMUM BEND RADIUS= 2.0[50.8]
1.) MOUNTING TORQUE: 20-27 Nm [15-20 FT-LBS].

UNLESS OTHERWISE SPECIFIED TOLERANCES ARE:		DRAWN		CHECKED		ENGINEER	
DIMENSIONS IN INCHES	DIMENSIONS IN MILLIMETERS [IN BRACKETS]	BB	11/25/15	ECB	11/25/15	EDB	11/25/15
DECIMALS XX ±.01 XXX ±.005	DECIMALS X ±.03 XX ±.013	TITLE INSTALLATION DRAWING MODEL 176M03 PRESSURE SENSOR					
ANGLES ± 2 DEGREES	ANGLES ± 2 DEGREES						
FILLETS AND RADII .003 - .005	FILLETS AND RADII 0.07 - 0.13	CODE IDENT. NO. 52681		DWG. NO. 31375		SCALE: .75X SHEET 1 OF 1	

PCB PIEZOTRONICS™
3425 WALDEN AVE. DEPEW, NY 14043
(716) 684-0001 E-MAIL: sales@pcb.com



LCIE

1 AVENANT D'ATTESTATION D'EXAMEN DE TYPE VOLONTAIRE

2 Appareil ou système de protection destiné à être utilisé en atmosphères explosibles (Directive 94/9/CE)

3 Numéro de l'avenant :
LCIE 06 ATEX 6041 X / 04

4 Appareil ou système de protection :
Capteur de pression haute température
Type : 176XYY/MZZZ-AA series

5 Demandeur : PCB Piezotronics Inc.

15 DESCRIPTION DE L'AVENANT

Mise à jour normative suivant la norme EN 60079-0:2012 + A11:2013.

Modification de l'élément piézoélectrique.
Modification du marquage pour le classement en température.

Modification du classement en température au paragraphe « Conditions spéciales pour une utilisation sûre ».

Les résultats des vérifications et essais figurent dans le rapport confidentiel N°134494-670162.

Paramètres spécifiques du ou des modes de protection concerné(s) : Inchangés.

Le marquage doit être : Modifié comme suit :

PCB Piezotronics

Adresse : ...

Type : 176XYY/MZZZ-AA (complété en fonction du modèle)

N° de fabrication : ...

Année de fabrication : ...

⊕ II 3 G

Ex nA IIC T6...T530°C Gc

Ex nA IIC T6...T660°C Gc

LCIE 06 ATEX 6041 X

16 DOCUMENTS DESCRIPTIFS

Dossier technique n°32142 rev.D du 24/02/2015.
Ce dossier comprend 5 rubriques (10 pages).

1 SUPPLEMENTARY VOLUNTARY TYPE EXAMINATION CERTIFICATE

2 Equipment or protective system intended for use in potentially explosive atmospheres (Directive 94/9/EC)

3 Supplementary certificate number :
LCIE 06 ATEX 6041 X / 04

4 Equipment or protective system :
High temperature pressure transducer
Type : 176XYY/MZZZ-AA series

5 Applicant : PCB Piezotronics Inc.

15 DESCRIPTION OF THE SUPPLEMENTARY CERTIFICATE

Normative update according to EN60079-0:2012 + A11:2013 standard.

Modification of the piezoelectric element.

Modification of the marking for the temperature classification.

Modification of the temperature classification in the clause "Special conditions for safe use".

The examination and test results are recorded in confidential report N°134494-670162.

Specific parameters of the concerned protection mode : Unchanged.

The marking shall be : Modified as follows :

PCB Piezotronics

Address : ...

Type : 176XYY/MZZZ-AA (completed with the model)

Serial number : ...

Year of construction : ...

⊕ II 3 G

Ex nA IIC T6...T530°C Gc

Ex nA IIC T6...T660°C Gc

LCIE 06 ATEX 6041 X

16 DESCRIPTIVE DOCUMENTS

Technical file n°32142 rev.D dated 2015/02/24.
This file includes 5 items (10 pages).

Fontenay-aux-Roses, le **04 AOUT 2015**

Le responsable de certification ATEX
ATEX Certification Officer



Rémi HANOT

Seul le texte en français peut engager la responsabilité du LCIE. Ce document ne peut être reproduit que dans son intégralité, sans aucune modification. The LCIE's liability applies only on the French text. This document may only be reproduced in its entirety and without any change.

Page 1 sur 2

01A-Annexe III_CE_typ_app_av - rev3.DOC

LCIE
Laboratoire Central
des Industries Electriques
Une société de Bureau Veritas

33, av du Général Leclerc
BP 8
92266 Fontenay-aux-Roses cedex
France

Tél : +33 1 40 95 60 60
Fax : +33 1 40 95 86 56
contact@lcie.fr
www.lcie.fr

Société par Actions Simplifiée
au capital de 15 715 981 €
RCS Nanterre B 408 363 174

36028 REV. K
ECO 44160
11/24/15

1/11

13 ANNEXE

14 AVENANT D'ATTESTATION D'EXAMEN DE TYPE VOLONTAIRE

LCIE 06 ATEX 6041 X / 04

17 CONDITIONS SPECIALES POUR UNE UTILISATION SURE

Modifiées comme suit :

Le capteur ne peut être raccordé qu'à un équipement dont les paramètres électriques n'excèdent pas les valeurs suivantes : U : 30V, I : 300mA.

Température ambiante d'utilisation : $0^{\circ}\text{C} \leq T_{\text{amb}} \leq +650^{\circ}\text{C}$.

Classement en température :

- Ex nA IIC T6 Gc ($T_{\text{amb}} \leq +80^{\circ}\text{C}$)
- Ex nA IIC T5 Gc ($T_{\text{amb}} \leq +95^{\circ}\text{C}$)
- Ex nA IIC T4 Gc ($T_{\text{amb}} \leq +130^{\circ}\text{C}$)
- Ex nA IIC T3 Gc ($T_{\text{amb}} \leq +195^{\circ}\text{C}$)
- Ex nA IIC T2 Gc ($T_{\text{amb}} \leq +290^{\circ}\text{C}$)
- Ex nA IIC T1 Gc ($T_{\text{amb}} \leq +440^{\circ}\text{C}$)
- Ex nA IIC T530°C Gc ($T_{\text{amb}} \leq +520^{\circ}\text{C}$)
- Ex nA IIC T660°C Gc ($T_{\text{amb}} \leq +650^{\circ}\text{C}$)

18 EXIGENCES ESSENTIELLES DE SECURITE ET DE SANTE

Couvertes par les normes EN 60079-0:2012 +A11:2013 et EN 60079-15:2010.

19 VERIFICATIONS ET ESSAIS INDIVIDUELS

Néant.

Désignation du modèle : 176XYY/MZZZ-AA :

- X = A à Z, code de la famille
- YY = 01 à 99, pour indiquer le montage, le câblage, le diaphragme ou le connecteur
- M : en option pour indiquer la longueur métrique du câble
- ZZZ = 001 à 999, en option pour indiquer la longueur métrique ($\leq 61\text{m}$) ou en pied (≤ 200 pieds) du câble
- AA = 01 à 99, en option pour indiquer la longueur du câble en pouces ou en centimètres

13 SCHEDULE

14 SUPPLEMENTARY VOLUNTARY TYPE EXAMINATION CERTIFICATE

LCIE 06 ATEX 6041 X / 04

17 SPECIAL CONDITIONS FOR SAFE USE

Modified as follows :

The transducer must be only connected to an equipment whose electrical parameters do not exceed the following values : U : 30V, I : 300 mA.

Operating ambient temperature : $0^{\circ}\text{C} \leq T_{\text{amb}} \leq +650^{\circ}\text{C}$.

Temperature classification :

- Ex nA IIC T6 Gc ($T_{\text{amb}} \leq +80^{\circ}\text{C}$)
- Ex nA IIC T5 Gc ($T_{\text{amb}} \leq +95^{\circ}\text{C}$)
- Ex nA IIC T4 Gc ($T_{\text{amb}} \leq +130^{\circ}\text{C}$)
- Ex nA IIC T3 Gc ($T_{\text{amb}} \leq +195^{\circ}\text{C}$)
- Ex nA IIC T2 Gc ($T_{\text{amb}} \leq +290^{\circ}\text{C}$)
- Ex nA IIC T1 Gc ($T_{\text{amb}} \leq +440^{\circ}\text{C}$)
- Ex nA IIC T530°C Gc ($T_{\text{amb}} \leq +520^{\circ}\text{C}$)
- Ex nA IIC T660°C Gc ($T_{\text{amb}} \leq +650^{\circ}\text{C}$)

18 ESSENTIAL HEALTH AND SAFETY REQUIREMENTS

Covered by the EN 60079-0:2012 + A11:2013 and EN 60079-15:2010 standards.

19 ROUTINE VERIFICATIONS AND TESTS

None.

Designation model : 176XYY/MZZZ-AA :

- X = A through Z for family code
- YY = 01 through 99 for indicate mounting, diaphragm, cabling or connector variations
- M is optional to indicate metric cable length
- ZZZ = 001 through 999 is optional to indicate cable length in feet (≤ 200 feet) or meters ($\leq 61\text{m}$).
- AA = 01 through 99 is optional to indicate fractional length of cable in inches or centimeters



L C I E

1 AVENANT D'ATTESTATION D'EXAMEN CE DE TYPE

2 Appareil ou système de protection destiné à être utilisé en atmosphères explosibles (Directive 94/9/CE)

3 Numéro de l'avenant :
LCIE 08 ATEX 6102 X / 04

4 Appareil ou système de protection :
Capteur de pression haute température
Type : 176XYY/MZZZ-AA series

5 Demandeur : PCB Piezotronics Inc.

15 DESCRIPTION DE L'AVENANT

Mise à jour normative suivant la norme EN 60079-0:2012 + A11 :2013.

Modification de l'élément piézoélectrique.
Modification du marquage pour le classement en température.

Modification du classement en température au paragraphe « Conditions spéciales pour une utilisation sûre ».

Les résultats des vérifications et essais figurent dans le rapport confidentiel N°134494-670162.

Paramètres spécifiques du ou des modes de protection concerné(s) :
Inchangés.

Le marquage doit être :

Modifié comme suit :

PCB Piezotronics

Adresse : ...

Type : 176XYY/MZZZ-AA (1)

N° de fabrication : ...

Année de fabrication : ...

⊕ II 1 G

Ex ia IIC T6...T530°C Ga

Ex ia IIC T6...T660°C Ga

LCIE 08 ATEX 6102 X

U_i : 30V, I_i : 300mA, P_i : 1W, C_i : 5nF, L_i : 0,5mH

(1)complété en fonction du modèle

16 DOCUMENTS DESCRIPTIFS

Dossier technique N°40678 rév.D du 24/02/2015.

Ce dossier comprend 5 rubriques (10 pages).

Fontenay-aux-Roses, le **04 AOUT 2015**

1 SUPPLEMENTARY EC TYPE EXAMINATION CERTIFICATE

2 Equipment or protective system intended for use in potentially explosive atmospheres (Directive 94/9/EC)

3 Supplementary certificate number :
LCIE 08 ATEX 6102 X / 04

4 Equipment or protective system :
High temperature pressure transducer
Type : 176XYY/MZZZ-AA series

5 Applicant : PCB Piezotronics Inc.

15 DESCRIPTION OF THE SUPPLEMENTARY CERTIFICATE

Normative update according to EN60079-0:2012 + A11:2013 standard.

Modification of the piezoelectric element.
Modification of the marking for the temperature classification.

Modification of the temperature classification in the clause "Special conditions for safe use".

The examination and test results are recorded in confidential report N°134494-670162.

Specific parameters of the concerned protection mode :
Unchanged.

The marking shall be :

Modified as follows :

PCB Piezotronics

Address :

Type : 176XYY/MZZZ-AA (1)

Serial number : ...

Year of construction : ...

⊕ II 1 G

Ex ia IIC T6...T530°C Ga

Ex ia IIC T6...T660°C Ga

LCIE 08 ATEX 6102 X

U_i : 30V, I_i : 300mA, P_i : 1W, C_i : 5nF, L_i : 0,5mH

(1)completed with the model

16 DESCRIPTIVE DOCUMENTS

Technical file N°40678 rev.D dated 2015/02/24.

This file includes 5 items (10 pages).

Le responsable de certification ATEX
ATEX Certification Officer



Seul le texte en français peut engager la responsabilité du LCIE. Ce document ne peut être reproduit que dans son intégralité, sans aucune modification.
The LCIE's liability applies only on the French text. This document may only be reproduced in its entirety and without any change.

Page 1 sur 2

01A-Annexe III_CE_typ_app_av - rev3 .DOC

LCIE
Laboratoire Central
des Industries Électriques
Une société de Bureau Veritas

33, av du Général Leclerc
BP 8
92266 Fontenay-aux-Roses cedex
France

Tél : +33 1 40 95 60 60
Fax : +33 1 40 95 86 56
contact@lcie.fr
www.lcie.fr

Société par Actions Simplifiée
au capital de 15 715 984 €
RCS Nanterre B 408 363 171

35028 REV. K
ECO 44160
11/24/15

L-01

13 ANNEXE

14 AVENANT D'ATTESTATION D'EXAMEN CE DE TYPE

LCIE 08 ATEX 6102 X / 04

17 CONDITIONS SPECIALES POUR UNE UTILISATION SURE

L'appareil ne peut être raccordé qu'à un matériel certifié de sécurité intrinsèque. Cette association doit être conforme vis-à-vis de la sécurité intrinsèque (voir les paramètres électriques au paragraphe 15).

Température ambiante d'utilisation : $0^{\circ}\text{C} \leq T_{amb} \leq +650^{\circ}\text{C}$

Classement en température :

- Ex ia IIC T6 Ga ($T_{amb} \leq +80^{\circ}\text{C}$)
- Ex ia IIC T5 Ga ($T_{amb} \leq +95^{\circ}\text{C}$)
- Ex ia IIC T4 Ga ($T_{amb} \leq +130^{\circ}\text{C}$)
- Ex ia IIC T3 Ga ($T_{amb} \leq +195^{\circ}\text{C}$)
- Ex ia IIC T2 Ga ($T_{amb} \leq +290^{\circ}\text{C}$)
- Ex ia IIC T1 Ga ($T_{amb} \leq +440^{\circ}\text{C}$)
- Ex ia IIC T530°C Ga ($T_{amb} \leq +520^{\circ}\text{C}$)
- Ex ia IIC T660°C Ga ($T_{amb} \leq +650^{\circ}\text{C}$)

18 EXIGENCES ESSENTIELLES DE SECURITE ET DE SANTE

Couvertes par les normes EN 60079-0:2012 + A11:2013 et EN 60079-11:2012.

19 VERIFICATIONS ET ESSAIS INDIVIDUELS

Néant.

Désignation du modèle : 176XYY/MZZZ-AA :

- X = A à Z, code de la famille
- YY = 01 à 99, pour indiquer le montage, le câblage, le diaphragme ou le connecteur
- M : en option pour indiquer la longueur métrique du câble
- ZZZ = 001 à 999, en option pour indiquer la longueur métrique ($\leq 61\text{m}$) ou en pied (≤ 200 pieds) du câble
- AA = 01 à 99, en option pour indiquer la longueur du câble en pouces ou en centimètres

13 SCHEDULE

14 SUPPLEMENTARY EC TYPE EXAMINATION CERTIFICATE

LCIE 08 ATEX 6102 X / 04

17 SPECIAL CONDITIONS FOR SAFE USE

The apparatus can be only connected to certified intrinsically safe equipment. This combination must be compatible as regards intrinsic safety rules (see electric parameters clause 15).

Operating ambient temperature : $0^{\circ}\text{C} \leq T_{amb} \leq +650^{\circ}\text{C}$

Temperature classification :

- Ex ia IIC T6 Ga ($T_{amb} \leq +80^{\circ}\text{C}$)
- Ex ia IIC T5 Ga ($T_{amb} \leq +95^{\circ}\text{C}$)
- Ex ia IIC T4 Ga ($T_{amb} \leq +130^{\circ}\text{C}$)
- Ex ia IIC T3 Ga ($T_{amb} \leq +195^{\circ}\text{C}$)
- Ex ia IIC T2 Ga ($T_{amb} \leq +290^{\circ}\text{C}$)
- Ex ia IIC T1 Ga ($T_{amb} \leq +440^{\circ}\text{C}$)
- Ex ia IIC T530°C Ga ($T_{amb} \leq +520^{\circ}\text{C}$)
- Ex ia IIC T660°C Ga ($T_{amb} \leq +650^{\circ}\text{C}$)

18 ESSENTIAL HEALTH AND SAFETY REQUIREMENTS

Covered by the EN 60079-0:2012 + A11:2013 and EN 60079-11:2012 standards.

19 ROUTINE VERIFICATIONS AND TESTS

None.

Designation model : 176XYY/MZZZ-AA :

- X = A through Z for family code
- YY = 01 through 99 for indicate mounting, diaphragm, cabling or connector variations
- M is optional to indicate metric cable length
- ZZZ = 001 through 999 is optional to indicate cable length in feet (≤ 200 feet) or meters ($\leq 61\text{m}$).
- AA = 01 through 99 is optional to indicate fractional length of cable in inches or centimeters



IECEx Certificate of Conformity

INTERNATIONAL ELECTROTECHNICAL COMMISSION IEC Certification Scheme for Explosive Atmospheres

for rules and details of the IECEx Scheme visit www.iecex.com

Certificate No.: **IECEx LCIE 12.0025X** issue No.: **1**

Certificate history:
Issue No. 1 (2015-8-4)
Issue No. 0 (2012-10-25)

Status: **Current**

Date of Issue: **2015-08-04** Page 1 of 4

Applicant: **PCB Piezotronics Inc.**
3425 Walden Avenue
Depew, New York 14043
United States of America

Electrical Apparatus: **High temperature pressure transducer type 176XYY/MZZZ-AA series**
Optional accessory:

Type of Protection: **ia**

Marking: PCB Address : ...
Type : 176XYY/MZZZ-AA (completed with the model)
Serial number : ... Year of construction : ...
Ex ia IIC T6...T530°C Ga, Ex ia IIC T6...T660°C Ga
IECEx LCIE 12.0025 X
Ui : 30V, li : 300mA, Pi : 1W, Ci : 5nF, Li : 0,5mH

Approved for issue on behalf of the IECEx
Certification Body:

Rémi Hanot

Position:

Certification Officer

Signature:
(for printed version)

Date:

2015/08/04

1. This certificate and schedule may only be reproduced in full.
2. This certificate is not transferable and remains the property of the issuing body.
3. The Status and authenticity of this certificate may be verified by visiting the [Official IECEx Website](http://www.iecex.com).

Certificate issued by:

Laboratoire Central des Industries Electriques (LCIE)
33 Avenue du General Leclerc
FR-92260 Fontenay-aux-Roses
France

Documents relative to LCIE certification activities (Certificates, QARs, ExTRs) can be registered under the references "LCI" or "LCIE".





IECEx Certificate of Conformity

Certificate No.: IECEx LCIE 12.0025X

Date of Issue: 2015-08-04

Issue No.: 1

Page 2 of 4

Manufacturer: **PCB Piezotronics Inc.**
3424 Walden Avenue
Depew, New York 14043
United States of America

Additional Manufacturing location
(s):

This certificate is issued as verification that a sample(s), representative of production, was assessed and tested and found to comply with the IEC Standard list below and that the manufacturer's quality system, relating to the Ex products covered by this certificate, was assessed and found to comply with the IECEx Quality system requirements. This certificate is granted subject to the conditions as set out in IECEx Scheme Rules, IECEx 02 and Operational Documents as amended.

STANDARDS:

The electrical apparatus and any acceptable variations to it specified in the schedule of this certificate and the identified documents, was found to comply with the following standards:

IEC 60079-0 : 2011 Explosive atmospheres - Part 0: General requirements
Edition: 6.0

IEC 60079-11 : 2011 Explosive atmospheres - Part 11: Equipment protection by intrinsic safety "I"
Edition: 6.0

*This Certificate **does not** indicate compliance with electrical safety and performance requirements other than those expressly included in the Standards listed above.*

TEST & ASSESSMENT REPORTS:

A sample(s) of the equipment listed has successfully met the examination and test requirements as recorded in

Test Report:

[FR/LCIE/ExTR12.0028/00](#)

[FR/LCIE/ExTR15.0069/00](#)

Quality Assessment Report:

[CA/CSA/QAR09.0018/00](#)

[CA/CSA/QAR09.0018/01](#)

[CA/CSA/QAR09.0018/02](#)



IECEx Certificate of Conformity

Certificate No.: IECEx LCIE 12.0025X

Date of Issue: 2015-08-04

Issue No.: 1

Page 3 of 4

Schedule

EQUIPMENT:

Equipment and systems covered by this certificate are as follows:

The sensor is made of an hermetically sealed metal housing containing only a piezo-crystal assembly connected to an integral cable (maximum length 61m).

Designation of the model : 176XYY/MZZZ-AA :

X = A through Z for family code

YY = 01 through 99 for indicate mounting, diaphragm, cabling or connector variations

M is optional to indicate metric cable length

ZZZ = 001 through 999 is optional to indicate cable length in feet (≤ 200 feet) or meters (≤ 61 m).

AA = 01 through 99 is optional to indicate fractional length of cable in inches or centimeters

Electrical parameters :

Ui : 30V, Ii : 300mA, Pi : 1W, Ci : 5nF, Li : 0,5mH

CONDITIONS OF CERTIFICATION: YES as shown below:

Operating ambient temperature : 0°C to +660°C.

Temperature classification :

Ex ia IIC T6 Ga ($T_{amb} \leq +80^{\circ}\text{C}$),

Ex ia IIC T5 Ga ($T_{amb} \leq +95^{\circ}\text{C}$),

Ex ia IIC T4 Ga ($T_{amb} \leq +130^{\circ}\text{C}$),

Ex ia IIC T3 Ga ($T_{amb} \leq +195^{\circ}\text{C}$),

Ex ia IIC T2 Ga ($T_{amb} \leq +290^{\circ}\text{C}$),

Ex ia IIC T1 Ga ($T_{amb} \leq +440^{\circ}\text{C}$),

Ex ia IIC T530°C Ga ($T_{amb} \leq +520^{\circ}\text{C}$),

Ex ia IIC T660°C Ga ($T_{amb} \leq +650^{\circ}\text{C}$)

The equipment must be only connected to a certified intrinsically safe equipment. This combination must be compatible regarding intrinsic safety rules.



IECEx Certificate of Conformity

Certificate No.: IECEx LCIE 12.0025X

Date of Issue: 2015-08-04

Issue No.: 1

Page 4 of 4

DETAILS OF CERTIFICATE CHANGES (for issues 1 and above):

Issue 1 : modification of the piezoelectric element, modification of the marking for the temperature classification, modification of the temperature classification in the clause "Conditions of certification".



IECEx Certificate of Conformity

INTERNATIONAL ELECTROTECHNICAL COMMISSION
IEC Certification Scheme for Explosive Atmospheres
for rules and details of the IECEx Scheme visit www.iecex.com

Certificate No.: **IECEx LCIE 12.0026X** issue No.: **1**
Status: **Current**
Date of Issue: **2015-08-04** Page 1 of 4

Certificate history:
Issue No. 1 (2015-8-4)
Issue No. 0 (2012-10-25)

Applicant: **PCB Piezotronics Inc.**
3425 Walden Avenue
Depew, New York 14043
United States of America

Electrical Apparatus: **High temperature pressure transducer type 176XYY/MZZZ-AA series**
Optional accessory:

Type of Protection: **nA**

Marking: PCB Address : ...
Type : 176XYY/MZZZ-AA (completed with the model)
Serial number : ... Year of construction :
Ex nA IIC T6...T530°C Gc, Ex nA IIC T6...T660°C Gc
IECEx LCIE 12.0026 X

Approved for issue on behalf of the IECEx
Certification Body:

Rémi Hanot

Position:

Certification Officer

Signature:
(for printed version)

Date:

2015/08/04

1. This certificate and schedule may only be reproduced in full.
2. This certificate is not transferable and remains the property of the issuing body.
3. The Status and authenticity of this certificate may be verified by visiting the [Official IECEx Website](http://www.iecex.com).

Certificate issued by:
Laboratoire Central des Industries Electriques (LCIE)
33 Avenue du General Leclerc
FR-92260 Fontenay-aux-Roses
France

Documents relative to LCIE certification activities (Certificates, QARs, ExTRs) can be registered under the references "LCI" or "LCIE".





IECEx Certificate of Conformity

Certificate No.: IECEx LCIE 12.0026X

Date of Issue: 2015-08-04

Issue No.: 1

Page 2 of 4

Manufacturer: **PCB Piezotronics Inc.**
3425 Walden Avenue
Depew, New York 14043
United States of America

Additional Manufacturing location
(s):

This certificate is issued as verification that a sample(s), representative of production, was assessed and tested and found to comply with the IEC Standard list below and that the manufacturer's quality system, relating to the Ex products covered by this certificate, was assessed and found to comply with the IECEx Quality system requirements. This certificate is granted subject to the conditions as set out in IECEx Scheme Rules, IECEx 02 and Operational Documents as amended.

STANDARDS:

The electrical apparatus and any acceptable variations to it specified in the schedule of this certificate and the identified documents, was found to comply with the following standards:

IEC 60079-0 : 2011 Explosive atmospheres - Part 0: General requirements
Edition: 6.0

IEC 60079-15 : 2010 Explosive atmospheres - Part 15: Equipment protection by type of protection "n"
Edition: 4

*This Certificate **does not** indicate compliance with electrical safety and performance requirements other than those expressly included in the Standards listed above.*

TEST & ASSESSMENT REPORTS:

A sample(s) of the equipment listed has successfully met the examination and test requirements as recorded in

Test Report:

[FR/LCIE/ExTR12.0029/00](#)

[FR/LCIE/ExTR15.0070/00](#)

Quality Assessment Report:

[CA/CSA/QAR09.0018/00](#)

[CA/CSA/QAR09.0018/01](#)

[CA/CSA/QAR09.0018/02](#)



IECEx Certificate of Conformity

Certificate No.: IECEx LCIE 12.0026X

Date of Issue: 2015-08-04

Issue No.: 1

Page 3 of 4

Schedule

EQUIPMENT:

Equipment and systems covered by this certificate are as follows:

The equipment is formed of a hermetically sealed metal housing containing only a piezo-crystal assembly connected to an integral cable.

Designation of the model : 176XYY/MZZZ-AA :

X = A through Z for family code

YY = 01 through 99 for indicate mounting, diaphragm, cabling or connector variations

M is optional to indicate metric cable length

ZZZ = 001 through 999 is optional to indicate cable length in feet (≤ 200 feet) or meters (≤ 61 m).

AA = 01 through 99 is optional to indicate fractional length of cable in inches or centimeters

CONDITIONS OF CERTIFICATION: YES as shown below:

Operating ambient temperature : 0°C to +660°C.

Temperature classification :

Ex nA IIC T6 Gc ($T_{amb} \leq +80^{\circ}\text{C}$),

Ex nA IIC T5 Gc ($T_{amb} \leq +95^{\circ}\text{C}$),

Ex nA IIC T4 Gc ($T_{amb} \leq +130^{\circ}\text{C}$),

Ex nA IIC T3 Gc ($T_{amb} \leq +195^{\circ}\text{C}$),

Ex nA IIC T2 Gc ($T_{amb} \leq +290^{\circ}\text{C}$),

Ex nA IIC T1 Gc ($T_{amb} \leq +440^{\circ}\text{C}$),

Ex nA IIC T530°C Gc ($T_{amb} \leq +520^{\circ}\text{C}$),

Ex nA IIC T660°C Gc ($T_{amb} \leq +650^{\circ}\text{C}$)

The equipment must be only connected to an equipment whose electrical parameters are compatible with the following values : U : 30V, I : 300mA.



IECEx Certificate of Conformity

Certificate No.: IECEx LCIE 12.0026X

Date of Issue: 2015-08-04

Issue No.: 1

Page 4 of 4

DETAILS OF CERTIFICATE CHANGES (for issues 1 and above):

Issue 1 : modification of the piezoelectric element, modification of the marking for the temperature classification, modification of the temperature classification in the clause "Conditions of certification".



Certificate of Compliance

Certificate: 1742175

Master Contract: 184981

Project: 70028573

Date Issued: June 22, 2015

Issued to: Industrial Monitoring Instr. (IMI)

A Div. of PCB Piezotronics, Inc.
3425 Walden Ave
Depew, NY 14043
USA
Attention: Nick Fulciniti

The products listed below are eligible to bear the CSA Mark shown with adjacent indicators 'C' and 'US' for Canada and US or with adjacent indicator 'US' for US only or without either indicator for Canada only.



Konstantin Rybalko

Issued by: Konstantin Rybalko

PRODUCTS

CLASS 2258 84 - PROCESS CONTROL EQUIPMENT - Intrinsically Safe, Entity - - For Hazardous Locations - Certified to US Standards

CLASS 2258 04 - PROCESS CONTROL EQUIPMENT - Intrinsically Safe, Entity - For Hazardous Locations

CLASS 2258 83 - PROCESS CONTROL EQUIPMENT-Intrinsically Safe and Non-Incendive - Systems-For Hazardous Locations-Certified to U.S. Standards

CLASS 2258 03 - PROCESS CONTROL EQUIPMENT - Intrinsically Safe and Non - Incendive Systems - For Hazardous Locations

Ex nA IIC Tx:

AEx nA IIC Tx:

Class I, Div. 2, Groups A, B, C, D:

Models 176XYY/MZZZ-AA High Temperature Pressure Transducer; non-incendive with entity parameters as shown below; must be installed per installation drawing 57723; temperature code as shown below; MWP 2000 psi.



Certificate: 1742175

Master Contract: 184981

Project: 70028573

Date Issued: June 22, 2015

Entity Parameters	Temperature Code
$U_i / V_{max} = 30V$	T6 (0°C to 80°C)
$I_i / I_{max} = 100mA$	T5 (0°C to 95°C)
$P_i / P_{max} = 1W$	T4 (0°C to 130°C)
$C_i = 5nF$	T3 (0°C to 195°C)
$L_i = 500\mu H$	T2 (0°C to 290°C)
	T1 (0°C to 440°C)
	T530 (0°C to 530°C)
	T660 (0°C to 650°C)

Notes:

1. For Canadian Installations, sensor case must be bonded to ground according to Section 18-182 of the CEC, Part 1.
2. For US Installations, sensor case must be bonded to ground according to Article 501.16 of the NEC.

CLASS2258 04 - PROCESS CONTROL EQUIPMENT - Intrinsically Safe Entity - For Hazardous Locations

CLASS2258 84 - PROCESS CONTROL EQUIPMENT - Intrinsically Safe Entity - For Hazardous Locations - CERTIFIED TO U.S. STANDARDS

Ex ia IIC Tx:

AEx ia IIC Tx:



Certificate: 1742175

Master Contract: 184981

Project: 70028573

Date Issued: June 22, 2015

Class I, Division 1, Groups A, B, C, D:

Models 176XYY/MZZZ-AA High Temperature Pressure Transducer; intrinsically safe with entity parameters as shown below; must be installed as per installation drawing 57723; temperature code as shown below; MWP 2000 psi.

Entity Parameters	Temperature Code
$U_i / V_{max} = 30V$	T6 (0°C to 80°C)
$I_i / I_{max} = 100mA$	T5 (0°C to 95°C)
$P_i / P_{max} = 1W$	T4 (0°C to 130°C)
$C_i = 5nF$	T3 (0°C to 195°C)
$L_i = 500\mu H$	T2 (0°C to 290°C)
	T1 (0°C to 440°C)
	T530 (0°C to 530°C)
	T660 (0°C to 650°C)

Notes:

1. For Canadian Installations, sensor case must be bonded to ground according to Section 18-182 of the CEC, Part 1.
2. For US Installations, sensor case must be bonded to ground according to Article 501.16 of the NEC.

APPLICABLE REQUIREMENTS



Certificate: 1742175

Master Contract: 184981

Project: 70028573

Date Issued: June 22, 2015

CAN/CSA-C22.2 No. 0-M91 (R2001)	General Requirements – Canadian Electrical Code, Part II
C22.2 No. 142-M1987 (R2009)	Process Control Equipment
CAN/CSA-C22.2 No. 157-92 (R2006)	Intrinsically Safe and Non-Incendive Equipment for Use in Hazardous Locations
C22.2 No. 213-M1987 (R2008)	Non-Incendive Electrical Equipment for Use in Class I, Division 2 Hazardous Locations
CAN/CSA-E60079-0:02	Electrical apparatus for explosive gas atmospheres - Part 11: Intrinsic Safety "i"
CAN/CSA-C22.2 No. 60079-11:11	Explosive Atmospheres – Part 11: Equipment protection by intrinsic safety "i"
CAN/CSA-E60079-15:02	Electrical apparatus for explosive gas atmospheres - Part 15: Type of Protection "n"
UL 916 (4th Ed.)	Energy Management Equipment
UL 913 (8h Ed.)	Intrinsically Safe Apparatus and Associated Apparatus for Use in Class I, II and III, Division 1, Hazardous Locations
FM Std. No. 3600-1998	Electrical Equipment for Use in Hazardous (Classified) Locations – General Requirements
FM Std. No. 3611-1999	Nonincendive Electrical Equipment for Use in Class I and II, Division 2, and Class III, Divisions 1 and 2, Hazardous (Classified) Locations
ANSI/UL 60079-15:02	Electrical Apparatus for Explosive Gas Atmospheres - Part 15: Type of Protection "n".
ANSI/UL 60079-0:13	Electrical Apparatus for Explosive Gas Atmospheres - Part 0: General Requirements
ANSI/UL 60079-11:13	Electrical apparatus for Explosive Gas Atmospheres - Part 11: Intrinsic Safety "i"



Supplement to Certificate of Compliance

Certificate: 1742175

Master Contract: 184981

The products listed, including the latest revision described below, are eligible to be marked in accordance with the referenced Certificate.

Product Certification History

Project	Date	Description
70028573	Jun 22, 2015	Update to the Report 1742175 for Model 176XYY/MZZ construction with alternative type of piezo crystal and additional temperature ranges.
2692514	May 23, 2014	Update to add Class I, Div. 1, Groups A, B, C, and D and AEx/Ex ia IIC T4...T1 markings.
1742175	May 4, 2006	Model 176Mxx High Temperature Pressure Transducer for Div. 2/Zone 2 Hazardous Locations.