



Model 137B24B
ICP® Pressure Sensor
Installation and Operating Manual

**For assistance with the operation of this product,
contact PCB Piezotronics, Inc.**

Toll-free: 800-828-8840
24-hour SensorLine: 716-684-0001
Fax: 716-684-0987
E-mail: info@pcb.com
Web: www.pcb.com



The information contained in this document supersedes all similar information that may be found elsewhere in this manual.

Total Customer Satisfaction – PCB Piezotronics guarantees Total Customer Satisfaction. If, at any time, for any reason, you are not completely satisfied with any PCB product, PCB will repair, replace, or exchange it at no charge. You may also choose to have your purchase price refunded in lieu of the repair, replacement, or exchange of the product.

Service – Due to the sophisticated nature of the sensors and associated instrumentation provided by PCB Piezotronics, user servicing or repair is not recommended and, if attempted, may void the factory warranty. Routine maintenance, such as the cleaning of electrical connectors, housings, and mounting surfaces with solutions and techniques that will not harm the physical material of construction, is acceptable. Caution should be observed to insure that liquids are not permitted to migrate into devices that are not hermetically sealed. Such devices should only be wiped with a dampened cloth and never submerged or have liquids poured upon them.

Repair – In the event that equipment becomes damaged or ceases to operate, arrangements should be made to return the equipment to PCB Piezotronics for repair. User servicing or repair is not recommended and, if attempted, may void the factory warranty.

Calibration – Routine calibration of sensors and associated instrumentation is

recommended as this helps build confidence in measurement accuracy and acquired data. Equipment calibration cycles are typically established by the users own quality regimen. When in doubt about a calibration cycle, a good “rule of thumb” is to recalibrate on an annual basis. It is also good practice to recalibrate after exposure to any severe temperature extreme, shock, load, or other environmental influence, or prior to any critical test.

PCB Piezotronics maintains an ISO-9001 certified metrology laboratory and offers calibration services, which are accredited by A2LA to ISO/IEC 17025, with full traceability to N.I.S.T. In addition to the normally supplied calibration, special testing is also available, such as: sensitivity at elevated or cryogenic temperatures, phase response, extended high or low frequency response, extended range, leak testing, hydrostatic pressure testing, and others. For information on standard recalibration services or special testing, contact your local PCB Piezotronics distributor, sales representative, or factory customer service representative.

Returning Equipment – *Following these procedures will insure that your returned materials are handled in the most expedient manner.* Before returning any equipment to PCB Piezotronics, contact your local distributor, sales representative, or factory customer service representative to obtain a Return

Materials Authorization (RMA) Number. This RMA number should be clearly marked on the outside of all package(s) and on the packing list(s) accompanying the shipment. A detailed account of the nature of the problem(s) being experienced with the equipment should also be included inside the package(s) containing any returned materials.

A Purchase Order, included with the returned materials, will expedite the turn-around of serviced equipment. It is recommended to include authorization on the Purchase Order for PCB to proceed with any repairs, as long as they do not exceed 50% of the replacement cost of the returned item(s). PCB will provide a price quotation or replacement recommendation for any item whose repair costs would exceed 50% of replacement cost, or any item that is not economically feasible to repair. For routine calibration services, the Purchase Order should include authorization to proceed and return at current pricing, which can be obtained from a factory customer service representative.

Warranty – All equipment and repair services provided by PCB Piezotronics, Inc. are covered by a limited warranty against defective material and workmanship for a period of one year from date of original purchase. Contact

PCB for a complete statement of our warranty. Expendable items, such as batteries and mounting hardware, are not covered by warranty. Mechanical damage to equipment due to improper use is not covered by warranty. Electronic circuitry failure caused by the introduction of unregulated or improper excitation power or electrostatic discharge is not covered by warranty.

Contact Information – International customers should direct all inquiries to their local distributor or sales office. A complete list of distributors and offices can be found at www.pcb.com. Customers within the United States may contact their local sales representative or a factory customer service representative. A complete list of sales representatives can be found at www.pcb.com. Toll-free telephone numbers for a factory customer service representative, in the division responsible for this product, can be found on the title page at the front of this manual. Our ship to address and general contact numbers are:

PCB Piezotronics, Inc.
3425 Walden Ave.
Depew, NY 14043 USA
Toll-free: (800) 828-8840
24-hour SensorLineSM: (716) 684-0001
Website: www.pcb.com
E-mail: info@pcb.com

OPERATION MANUAL FOR FREE FIELD BLAST PRESSURE PROBE Models 137B21X, B22X, B23X, B24X

1.0 INTRODUCTION

The Series 137B2XX Free Field Blast ICP[®] Pressure Probe is designed for measuring free field blast and shock tunnel pressure time profiles.

Designed with an ICP[®] built-in source follower amplifier, the 137B2XX Series offers sensitivities of 1, 20, 10 and 100 mV/psi with full-scale ranges from 0 to 50, 250, 500 or 5000 psi. The 137B2XX Series is constructed with a stable quartz piezoelectric element in an Invar housing



Photo 2

2.0 INSTALLATION

In field blast measurements, mount the Series 137B2XX pressure probe in an axial direction to the blast source. The probes should be elevated high enough off of the ground such that ground does not interfere with the measured pressure. See photo 1.

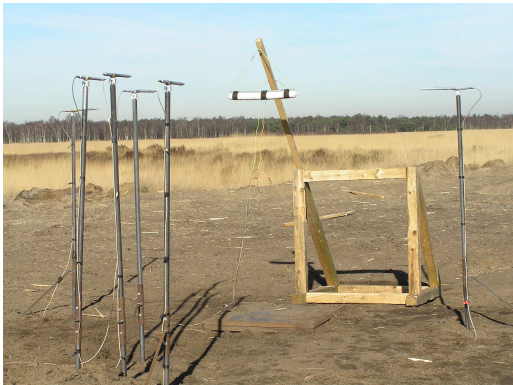

Photo 1

The sensing surface should be aligned in a vertical plane with respect to the ground as shown in photo 2. Avoiding direct exposure of the diaphragm to sunlight is good practice so that changing temperatures throughout a test day do not change the sensitivity of the sensor. In any case care must be taken such that the sensor's diaphragm is not oriented down to avoid ground reflections.

In some cases, where flash temperatures such as those generated by blasts and shock fronts are present, it may be necessary to thermally insulate the diaphragm to minimize signals generated by these effects.

Common black vinyl electrical tape has been found to be an effective thermal insulating material in many cases. One layer may be used across the end of diaphragm and adaptor. See photo 3.



Photo 3

A silicone rubber coating approximately 0.010 inch (0.25 mm) thick has also been proven effective in many applications. General Electric RTV type 106 is recommended (PCB Model 065A67). Apply the rubber coating to the surface of the diaphragm and allow it to cure in accordance with the manufacturer's instructions.

3.0 OPERATION

Using suitable cable, connect the sensor to one of PCB's Series 480, 481, 482, 483, or 484 signal conditioners or equivalent power supply. If using a PCB line power unit, the equipment will supply the 137B2XX with an adjustable 2 to 20 mA constant current at +22 to +30 VDC through a current-regulating circuit. If using a battery-operated unit, the constant current is 2 mA. See Guide G-0001 for powering and signal utilization information pertinent to all ICP[®] instrumentation.

**OPERATION MANUAL FOR
FREE FIELD BLAST PRESSURE PROBE
Models 137B21X, B22X, B23X, B24X**

Switch power on and observe reading of bias monitoring voltmeter on front panel of signal conditioner.

If indicator is in green section of indicator panel, the IC amplifier is producing proper bias (8 to 14 VDC), the cable connections are normal, and the system is ready to operate.

If the pointer moves into the red area of the fault monitor meter, output is zero and a short is indicated. The short could be located in amplifier cable connectors or power unit.

If the pointer moves into the yellow area of the fault monitor meter, an open circuit is indicated with full power supply voltage.

An open circuit could be the result of a faulty amplifier, an open cable or open connectors. Check to be sure connectors are properly mated. Some PCB power units feature fault LEDs in place of a fault meter. Instead of a pointer, the fault LED will light when an open or short circuit condition is present.

Allow the sensor to thermally stabilize for about one minute. A signal drift may occur when the cable is connected to the readout instrument. This drift occurs during charging of the coupling capacitor in the power unit. The signal will stabilize in several minutes. Proceed with measurements.

Most line-powered signal conditioners manufactured by PCB have an adjustable current feature allowing a choice of input currents from 2 to 20 mA. In general, for the lowest noise (best resolution), choose the lower current ranges.

In order to maintain a high frequency response of the system when driving long cables (to hundreds or thousands of feet), use a higher current, up to 20 mA maximum. Use of low-capacitance cable (i.e. RG 62/U) and impedance-matching variable resistors are suggested to improve long cable performance characteristics. See Guide G-0001 for a discussion on cable considerations.

3.1 POLARITY

The 137B2XX Series produces a positive-going output voltage for increasing pressure output.

4.0 LOW-FREQUENCY RESPONSE

Consult Section 7.0 in General Guide G-0001 for detailed explanation of low-frequency characteristics of ICP[®] instrumentation.

5.0 CALIBRATION

Do not try to calibrate the Series 137B2XX statically. The Series 137B2XX is calibrated dynamically by PCB using a hydraulic pulse technique.

For best accuracy, use the calibration certificate supplied. Factory recalibration is available for a nominal charge.

6.0 MAINTENANCE

Although ICP[®] sensors have low-output impedance and are not usually affected by moisture, in extremely damp environments it may be well to protect cable connections with shrink tubing.



It is well to observe the following precautions in using the sensor:

1. Do not exceed specified maximum range.
2. Do not subject sensor to temperatures exceeding temperature shown on specification sheet.
3. Do not apply voltage to sensor without current-limiting diodes or other current protection.
4. Do not apply more than 20 mA of current to the sensor.

Field repair of the piezoelectric element or amplifier of the Series 137B2XX is not practicable. Thus, should a sensor in this series require servicing, refer to the warranty sheet.

CAUTIONARY NOTE: If sensors are left outside overnight, they should be coated with silicone oil and covered. The protective silicone oil or grease coating should also be applied when the sensors are operated in a humid or rainy environment.

®ICP is a registered trademark of PCB Piezotronics

Model Number 137B24B	ICP® PRESSURE SENSOR		Revision: A ECN #: 41884											
Performance Measurement Range(for ±5V output) Measurement Range(for ±10V output) Sensitivity(± 15 %) Maximum Pressure Resolution Resonant Frequency Rise Time(Incident) Non-Linearity	ENGLISH 250 psi 500 psi 20 mV/psi 5 kpsi .7 mpsi ≥ 400 kHz ≤ 6.5 μ sec ≤ 1.0 % FS	SI 1724 kPa 3447 kpsi 2.90 mV/kPa 34,474 kPa .005 kPa ≥ 400 kHz ≤ 6.5 μ sec ≤ 1.0 % FS	OPTIONAL VERSIONS Optional versions have identical specifications and accessories as listed for the standard model except where noted below. More than one option may be used.	NOTES: [1] For +10 volt output, minimum 26 VDC supply voltage required. Negative 10 volt output may be limited by output bias. [2] Typical. [3] Zero-based, least-squares, straight line method. [4] See PCB Declaration of Conformance PS023 for details.										
Environmental Temperature Range(Operating) Temperature Coefficient of Sensitivity	-100 to +275 °F ≤ 0.05 %/°F	-73 to +135 °C ≤ 0.090 %/°C												
Electrical Discharge Time Constant(at room temp) Excitation Voltage Constant Current Excitation Output Impedance Output Bias Voltage	≥ 0.2 sec 20 to 30 VDC 2 to 20 mA ≤ 200 Ohm 8 to 14 VDC	≥ 0.2 sec 20 to 30 VDC 2 to 20 mA ≤ 200 Ohm 8 to 14 VDC	SUPPLIED ACCESSORIES: Model PCS-6 Calibration of Series 134, 137, and 138 (1)	<table border="1"> <tr> <td>Entered: AP</td> <td>Engineer: JDK</td> <td>Sales: RWM</td> <td>Approved: BAM</td> <td>Spec Number:</td> </tr> <tr> <td>Date: 8/14/2013</td> <td>Date: 8/14/2013</td> <td>Date: 8/14/2013</td> <td>Date: 8/14/2013</td> <td style="text-align: center;">55320</td> </tr> </table>	Entered: AP	Engineer: JDK	Sales: RWM	Approved: BAM	Spec Number:	Date: 8/14/2013	Date: 8/14/2013	Date: 8/14/2013	Date: 8/14/2013	55320
Entered: AP	Engineer: JDK	Sales: RWM			Approved: BAM	Spec Number:								
Date: 8/14/2013	Date: 8/14/2013	Date: 8/14/2013	Date: 8/14/2013	55320										
Physical Sensing Geometry Sensing Element Housing Material Diaphragm Sealing Electrical Connector Weight	Compression Quartz Aluminum Invar Epoxy BNC Jack 12.4 oz	Compression Quartz Aluminum Invar Epoxy BNC Jack 352 gm	<table border="1"> <tr> <td>Entered: AP</td> <td>Engineer: JDK</td> <td>Sales: RWM</td> <td>Approved: BAM</td> <td>Spec Number:</td> </tr> <tr> <td>Date: 8/14/2013</td> <td>Date: 8/14/2013</td> <td>Date: 8/14/2013</td> <td>Date: 8/14/2013</td> <td style="text-align: center;">55320</td> </tr> </table>	Entered: AP	Engineer: JDK	Sales: RWM	Approved: BAM	Spec Number:	Date: 8/14/2013	Date: 8/14/2013	Date: 8/14/2013	Date: 8/14/2013	55320	<div style="display: flex; justify-content: space-between;"> <div data-bbox="1123 893 1575 974">  <p>3425 Walden Avenue, Depew, NY 14043</p> </div> <div data-bbox="1638 893 1890 974"> <p>Phone: 716-684-0001 Fax: 716-684-0987 E-Mail: info@pcb.com</p> </div> </div>
Entered: AP	Engineer: JDK	Sales: RWM		Approved: BAM	Spec Number:									
Date: 8/14/2013	Date: 8/14/2013	Date: 8/14/2013	Date: 8/14/2013	55320										
<div style="display: flex; align-items: center;">  <p>[4]</p> </div> <p>All specifications are at room temperature unless otherwise specified. In the interest of constant product improvement, we reserve the right to change specifications without notice. ICP® is a registered trademark of PCB Group, Inc.</p>														

2

1

PCB Piezotronics Inc. claims proprietary rights in the information disclosed hereon. Neither it nor any reproduction thereof will be disclosed to others without the written consent of PCB Piezotronics Inc.

REVISIONS

REV	DESCRIPTION	DIN
NR	RELEASED TO DRAFTING	37217

46930

B

B

A

A

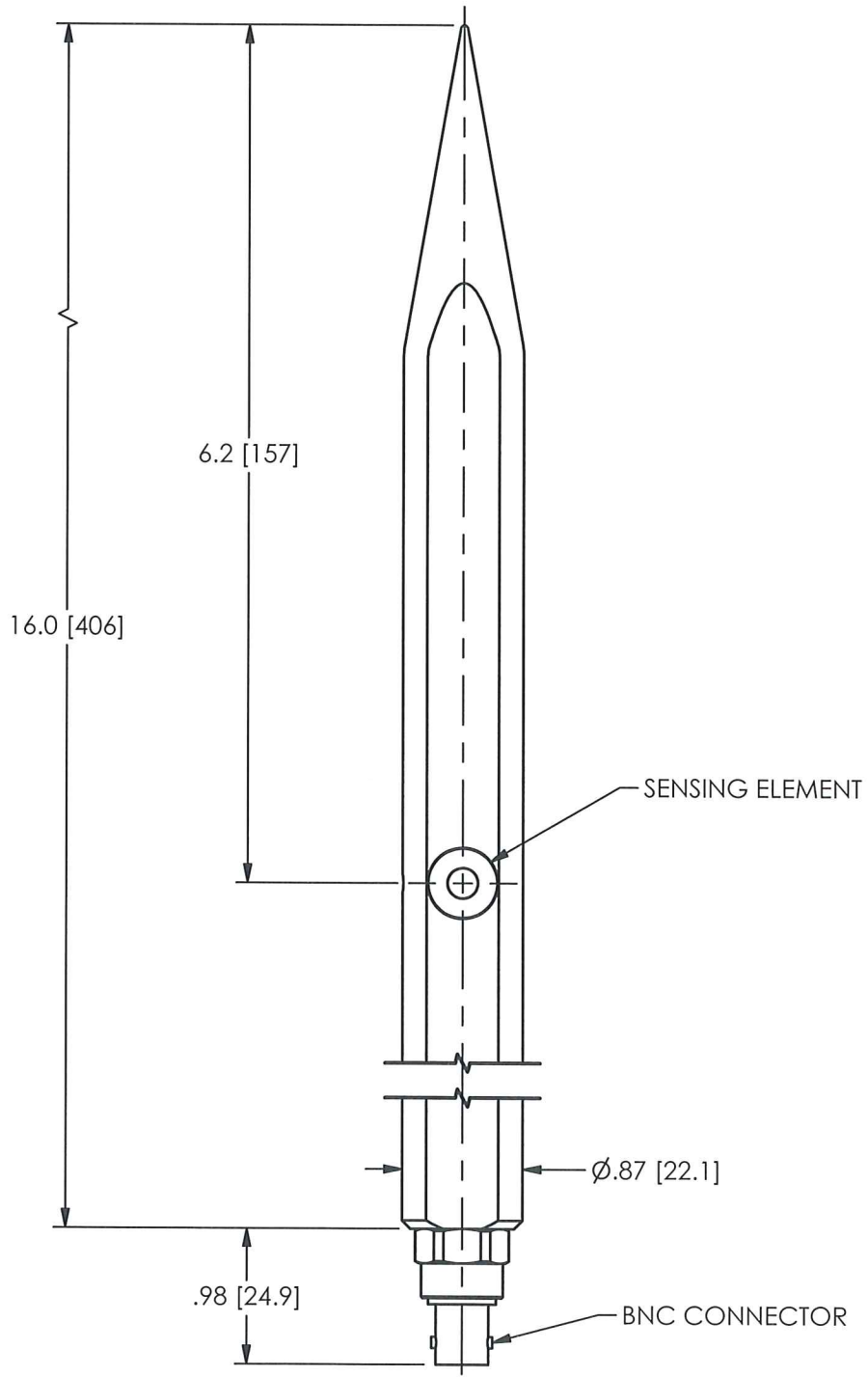

UNLESS OTHERWISE SPECIFIED TOLERANCES ARE:

DIMENSIONS IN INCHES	DIMENSIONS IN MILLIMETERS [IN BRACKETS]
DECIMALS XX ±.03 XXX ±.010	DECIMALS X ± 0.8 XX ± 0.25
ANGLES ± 2 DEGREES	ANGLES ± 2 DEGREES
FILLETS AND RADII .003 - .005	FILLETS AND RADII 0.07 - 0.13

DRAWN		CHECKED		ENGINEER	
SMB	10/10/11	<i>[Signature]</i>		MJN	10/10/11

TITLE

OUTLINE DRAWING
MODEL 137BXXB SERIES
FREE FIELD BLAST PROBE

PCB PIEZOTRONICS INC
3425 WALDEN AVE. DEPEW, NY 14043
(716) 684-0001 E-MAIL: sales@pcb.com

CODE IDENT. NO. 52681	DWG. NO. 46930
--------------------------	-------------------

SCALE: .75X	SHEET 1 OF 1
-------------	--------------

2

1

1