



Model 130F21

ICP® Electret Array Microphone

Installation and Operating Manual

**For assistance with the operation of this product,
contact PCB Piezotronics, Inc.**

**Toll-free: 800-828-8840
24-hour SensorLine: 716-684-0001
Fax: 716-684-0987
E-mail: info@pcb.com
Web: www.pcb.com**





Service, Repair, and Return Policies and Instructions
--

The information contained in this document supersedes all similar information that may be found elsewhere in this manual.

Service – Due to the sophisticated nature of the sensors and associated instrumentation provided by PCB Piezotronics, user servicing or repair is not recommended and, if attempted, may void the factory warranty. Routine maintenance, such as the cleaning of electrical connectors, housings, and mounting surfaces with solutions and techniques that will not harm the physical material of construction, is acceptable. Caution should be observed to ensure that liquids are not permitted to migrate into devices that are not hermetically sealed. Such devices should only be wiped with a dampened cloth and never submerged or have liquids poured upon them.

Repair – In the event that equipment becomes damaged or ceases to operate, arrangements should be made to return the equipment to PCB Piezotronics for repair. User servicing or repair is not recommended and, if attempted, may void the factory warranty.

Calibration – Routine calibration of sensors and associated instrumentation is recommended as this helps build confidence in measurement accuracy and acquired data. Equipment calibration cycles are typically established by the users own quality regimen. When in doubt about a calibration cycle, a good “rule of thumb” is to recalibrate on an annual basis. It is

also good practice to recalibrate after exposure to any severe temperature extreme, shock, load, or other environmental influence, or prior to any critical test.

PCB Piezotronics maintains an ISO-9001 certified metrology laboratory and offers calibration services, which are accredited by A2LA to ISO/IEC 17025, with full traceability to SI through N.I.S.T. In addition to the normally supplied calibration, special testing is also available, such as: sensitivity at elevated or cryogenic temperatures, phase response, extended high or low frequency response, extended range, leak testing, hydrostatic pressure testing, and others. For information on standard recalibration services or special testing, contact your local PCB Piezotronics distributor, sales representative, or factory customer service representative.

Returning Equipment – *Following these procedures will ensure that your returned materials are handled in the most expedient manner.* Before returning any equipment to PCB Piezotronics, contact your local distributor, sales representative, or factory customer service representative to obtain a Return **Warranty, Service, Repair, and Return Policies and Instructions** Materials Authorization (RMA) Number. This RMA number should be clearly marked on the outside of all package(s) and on the packing

list(s) accompanying the shipment. A detailed account of the nature of the problem(s) being experienced with the equipment should also be included inside the package(s) containing any returned materials.

A Purchase Order, included with the returned materials, will expedite the turn-around of serviced equipment. It is recommended to include authorization on the Purchase Order for PCB to proceed with any repairs, as long as they do not exceed 50% of the replacement cost of the returned item(s). PCB will provide a price quotation or replacement recommendation for any item whose repair costs would exceed 50% of replacement cost, or any item that is not economically feasible to repair. For routine calibration services, the Purchase Order should include authorization to proceed and return at current pricing, which can be obtained from a factory customer service representative.

Contact Information – International customers should direct all inquiries to their local distributor or sales office. A

complete list of distributors and offices can be found at www.pcb.com. Customers within the United States may contact their local sales representative or a factory customer service representative. A complete list of sales representatives can be found at www.pcb.com. Toll-free telephone numbers for a factory customer service representative, in the division responsible for this product, can be found on the title page at the front of this manual. Our ship to address and general contact numbers are:

PCB Piezotronics, Inc.
3425 Walden Ave.
Depew, NY14043 USA
Toll-free: (800) 828-8840
24-hour SensorLineSM: (716) 684-0001
Website: www.pcb.com
E-mail: info@pcb.com



PCB工业监视和测量设备 - 中国RoHS2公布表
PCB Industrial Monitoring and Measuring Equipment - China RoHS 2 Disclosure Table

部件名称	有害物质					
	铅 (Pb)	汞 (Hg)	镉 (Cd)	六价铬 (Cr(VI))	多溴联苯 (PBB)	多溴二苯醚 (PBDE)
住房	○	○	○	○	○	○
PCB板	X	○	○	○	○	○
电气连接器	○	○	○	○	○	○
压电晶体	X	○	○	○	○	○
环氧	○	○	○	○	○	○
铁氟龙	○	○	○	○	○	○
电子	○	○	○	○	○	○
厚膜基板	○	○	X	○	○	○
电线	○	○	○	○	○	○
电缆	X	○	○	○	○	○
塑料	○	○	○	○	○	○
焊接	X	○	○	○	○	○
铜合金/黄铜	X	○	○	○	○	○
本表格依据 SJ/T 11364 的规定编制。						
○：表示该有害物质在该部件所有均质材料中的含量均在 GB/T 26572 规定的限量要求以下。						
X：表示该有害物质至少在该部件的某一均质材料中的含量超出 GB/T 26572 规定的限量要求。						
铅是欧洲RoHS指令2011/65/ EU附件三和附件四目前由于允许的豁免。						

CHINA RoHS COMPLIANCE

Component Name	Hazardous Substances					
	Lead (Pb)	Mercury (Hg)	Cadmium (Cd)	Chromium VI Compounds (Cr(VI))	Polybrominated Biphenyls (PBB)	Polybrominated Diphenyl Ethers (PBDE)
Housing	O	O	O	O	O	O
PCB Board	X	O	O	O	O	O
Electrical Connectors	O	O	O	O	O	O
Piezoelectric Crystals	X	O	O	O	O	O
Epoxy	O	O	O	O	O	O
Teflon	O	O	O	O	O	O
Electronics	O	O	O	O	O	O
Thick Film Substrate	O	O	X	O	O	O
Wires	O	O	O	O	O	O
Cables	X	O	O	O	O	O
Plastic	O	O	O	O	O	O
Solder	X	O	O	O	O	O
Copper Alloy/Brass	X	O	O	O	O	O

This table is prepared in accordance with the provisions of SJ/T 11364.

O: Indicates that said hazardous substance contained in all of the homogeneous materials for this part is below the limit requirement of GB/T 26572.

X: Indicates that said hazardous substance contained in at least one of the homogeneous materials for this part is above the limit requirement of GB/T 26572.

Lead is present due to allowed exemption in Annex III or Annex IV of the European RoHS Directive 2011/65/EU.

DOCUMENT NUMBER: 21354

DOCUMENT REVISION: **D**

ECN: 46162

OPERATING GUIDE FOR 130 SERIES MICROPHONES

Contents:

1.0 Introduction.....	1
2.0 Product Description	1
3.0 Powering	2
4.0 Installation.....	3
5.0 Calibration.....	3
6.0 Service.....	7
7.0 Warranty.....	7

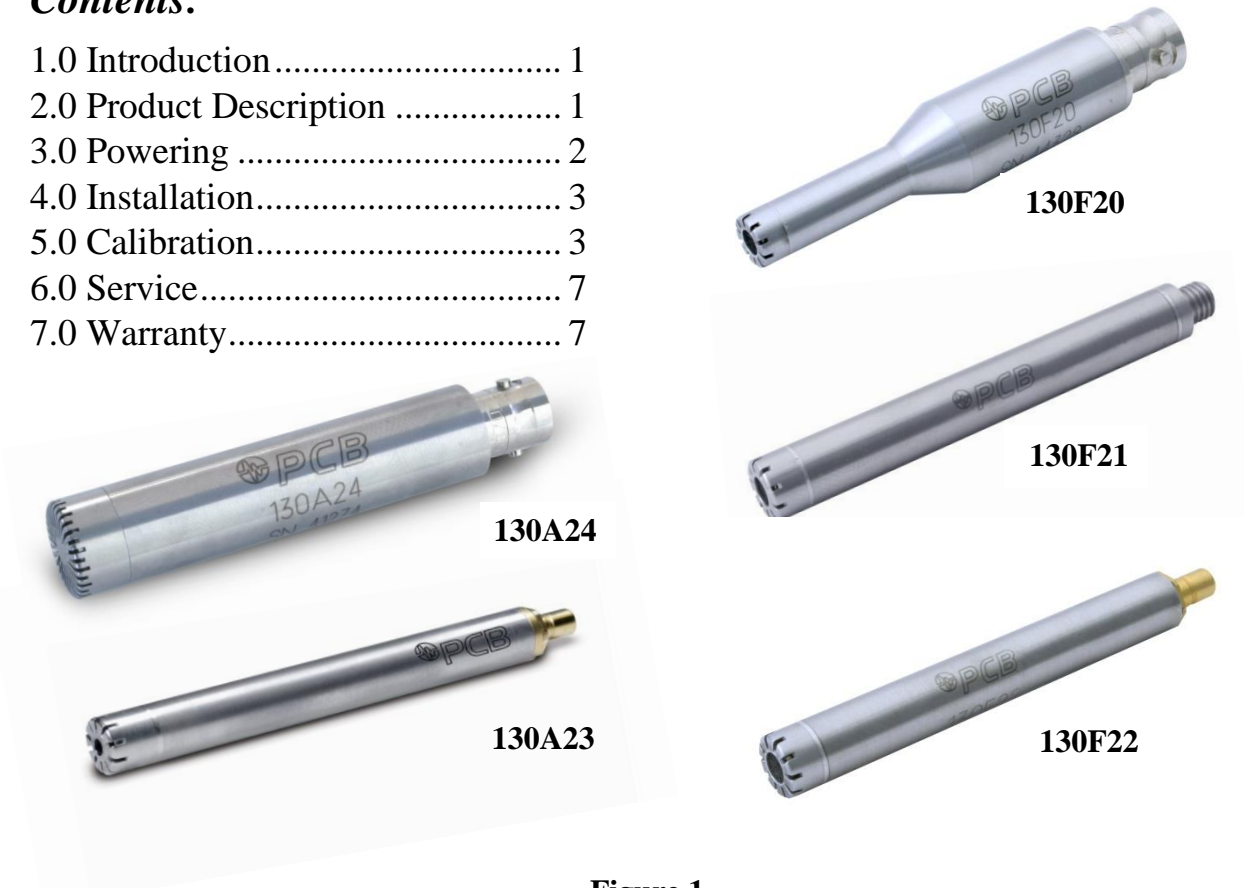

Figure 1

1.0 Introduction

PCB[®] 130 series ICP[®] array microphones provide an extremely cost-effective method for large channel count sound pressure measurements. Multiple array microphones with their excellent phase characteristics can be combined with the appropriate software to perform measurements that are not possible with a single microphone. Typical applications include sound pressure mapping, beamforming, acoustic mode analysis, near-field acoustic holography, or sound intensity measurements. To ensure the best performance from your 130 series microphone follow the installation and operating procedures in this guide. If you have additional questions concerning the microphone system or applications, call a factory Application Engineer at 716-684-0001, or your nearest PCB[®] Field Application Engineer.

2.0 Product Description

PCB[®]'s 130 series ICP[®] Array are integrated systems that include a built-in preamplifier. Models 130F20, 130F21, and 130F22 are all ¼-inch microphones that provide a 45 mV/Pa output over an extended 120dB dynamic range. They are ideal for use at frequencies from 20 Hz to 10 kHz (± 2dB) or 20 kHz (± 5dB). All models are of rugged, stainless steel construction .

These microphones all have the same performance specifications but are fitted with different electrical connectors to make them suitable for differing applications. Model 130F20 features a BNC connector while Model 130F21 uses a 10-32 coaxial jack connector. Model 130F22 terminates in a SMB connector. These models are shown in Figure 1.

The 130A23 and 130A24 are designed for high amplitude applications with an upper dynamic range of 150 dB. Model 130A23 terminates in a SMB electrical connector. The 130A24 is an enhanced, rugged, water and dust resistant design, and terminates in a BNC electrical connector. Model 130A24 has a lower sensitivity (10 mV/Pa) than the 130A23 (14 mV/Pa), but otherwise the performance specifications are the same.

All 130 Series array microphones include TEDS capable digital memory and communication electronics compliant with IEEE 1451.4. These microphones are easy to operate and interface with many PCB® ICP® constant current signal conditioners and other data acquisition and recording instruments available on the market today. In a complete microphone system, low-impedance cables couple the microphone and signal conditioner to customer supplied read-out instruments. The use of low impedance cables enables signals to be driven long distances with negligible signal loss.

3.0 Powering

All ICP® powered microphones require constant-current excitation for proper operation. For this reason, use only PCB constant-current signal conditioners or other approved constant-current sources. The signal conditioner provides an AC-coupled output signal that is compatible with most standard readout devices. Signal conditioners consist of a regulated 2-20mA, 18-30 VDC source. They are available in single or multi channel, battery or line powered configurations. Battery powered devices offer versatility for portable low noise measurements, whereas line powered units provide the capability for continuous monitoring. A typical system schematic is shown in Figure 2.

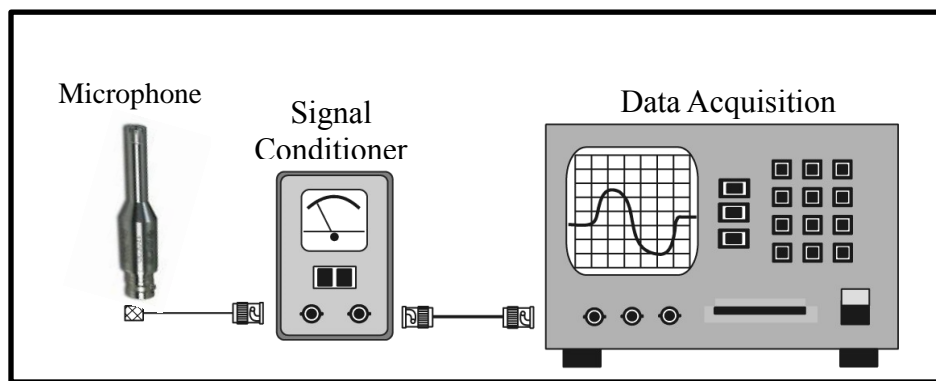

Figure 2

Signal conditioners have meters or LEDs, which enable users to monitor the bias voltage output signal, check microphone operation, and detect cable faults. Typically yellow denotes an open circuit; green indicates normal operation and red indicates a short circuit. Many FFT analyzers, data acquisition modules, and data collectors have the proper constant-current excitation built-in for direct use with ICP® microphones. Before using this feature, care should be taken to assure the proper supply voltage and constant current excitation are provided. Check the enclosed specification sheet to make sure the supply voltage and current are within acceptable limits for your particular microphone.

4.0 Installation

There are many ways to mount the microphone, from simply placing the microphone in a clip to using a two-dimensional array stand. A diagram of an array configuration is provided in Figure 3. For installation of this type, remove the microphone from its package, connect the appropriate cable between the signal conditioner and the microphone, and connect a second cable between the signal conditioner and the data acquisition device. Cabling may consist of standard low-impedance coax cables. Desired electrical connectors would be dependent on the 130 series microphone used and the input of the signal conditioner and read-out instrument. PCB® offers these cables in a variety of standard or customer specified lengths.

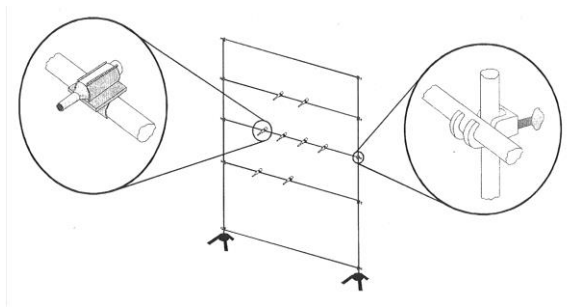

Figure 3

The 130A24 microphone features a removable grid cap and replaceable protective cover. This allows the 130A24 to withstand harsh environments while extending the lifespan of critical sensitive components. If the water and dust resistant cover is damaged, having a removable grid cap allows the user to replace this protective cover quickly and easily.

To replace a grid cap, first unthread the grid cap from the housing. Next, peel off the existing cover from the end of the housing. Sharp edged tools can be used to aid in cover removal, but it is important to keep the tool at a shallow angle. DO NOT make contact with the microphone's delicate diaphragm (right hand side of Figure 4). To ensure a proper seal, gently wipe the top of the microphone housing to remove any moisture or debris. Do not use solvent when removing debris from the housing because solvents have the potential to damage the microphone. Apply the replacement water resistant patch to the end of the housing (left hand side of Figure 4) while keeping it centered. Finally, assemble the grid cap back onto the housing. Additional 079A46 five-pack replacement water resistant pads can be ordered separately.



Figure 4

5.0 Calibration

All microphones are supplied with calibration documentation showing the free field frequency response and the conditions under which the calibration was performed. Calibrations are performed with reference microphones traceable to national laboratories specializing in acoustic measurements (NIST, PTB, or DFM). PCB is ISO 10012-1 and ISO 9001-2008 certified. Calibration methods used by PCB for acoustic pressure have been audited for proficiency and accredited for compliance with ISO/IEC 17025:2005; ANSI/NCSL Z540-1-1994 & ANSI/NCSL Z540.3. Sample calibration certificates are provided in Figure 5, Figure 6, and Figure 7 for the 130F series, 130A23, and 130A24, respectively.

~ Calibration Certificate ~

Model Number: 130F20
Serial Number: 43998
Description: ICP® Microphone
Manufacturer: PCB

Calibration Data

Sensitivity: 44.2 mV/Pa
-27.1 dB re 1V/Pa
Reference Freq.: 250 Hz
Output Bias: 9.8 VDC
Temperature: 73 °F 23 °C
Relative Humidity: 60 %

Response Plot

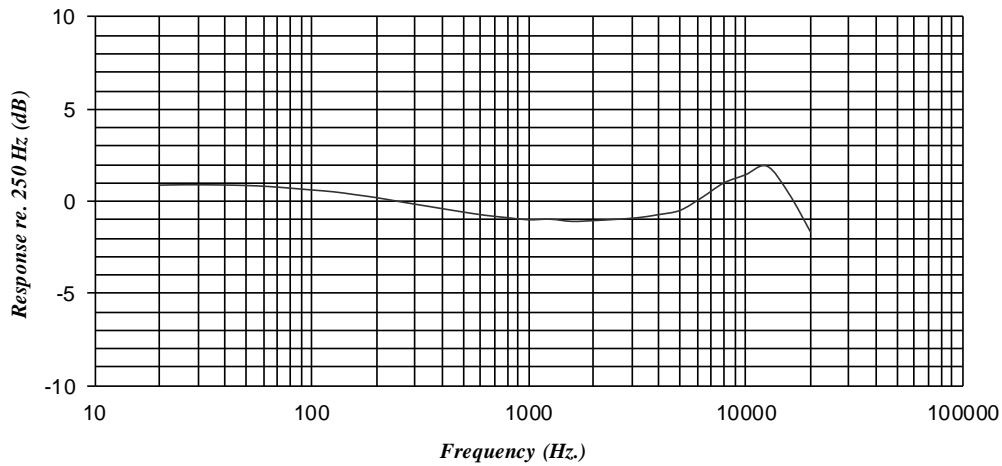

Condition of Unit

As Found: n/a
As Left: New Unit, In Tolerance

Notes

1. Frequency response determined by IEC 61094-5: Methods for pressure calibration of working standard microphones by comparison.
2. Calibration of reference equipment is traceable to one or more of the following National Labs: NIST, PTB or DFM.
3. Calibration is performed in compliance with ISO 9001, ISO 10012-1 and ANSI/NC SL Z540.3.
4. Due to state-of-the-art limitations, 4:1 calibration ratios are not possible on pressure measurement standards, microphones and acoustic calibrators. Calibration ratios for these types of devices are limited to 1:1.
5. See Manufacturer's Specification Sheet for a detailed listing of performance specifications.
6. This certificate shall not be reproduced, except in full, without written approval from PCB Piezotronics, Inc
7. Calibrated per ACS-21.

Technician: Isaac Miller Date: May 16, 2016



Headquarters: 3425 Walden Avenue, Depew, NY 14043

Calibration performed at: 10869 Highway 903, Halifax, NC 27839

Figure 5

~ Calibration Certificate ~

Model Number: 130A23

Serial Number: 45002

Description: ICP® Microphone

Manufacturer: PCB

Method ¹: Back-to-Back Reference

Calibration Data

Sensitivity: 12.2 mV/Pa
-38.3 dB re 1V/Pa

Reference Freq.: 250 Hz
Output Bias: 11.8 VDC

Temperature: 72 °F 22 °C

Relative Humidity: 44 %

Response Plot

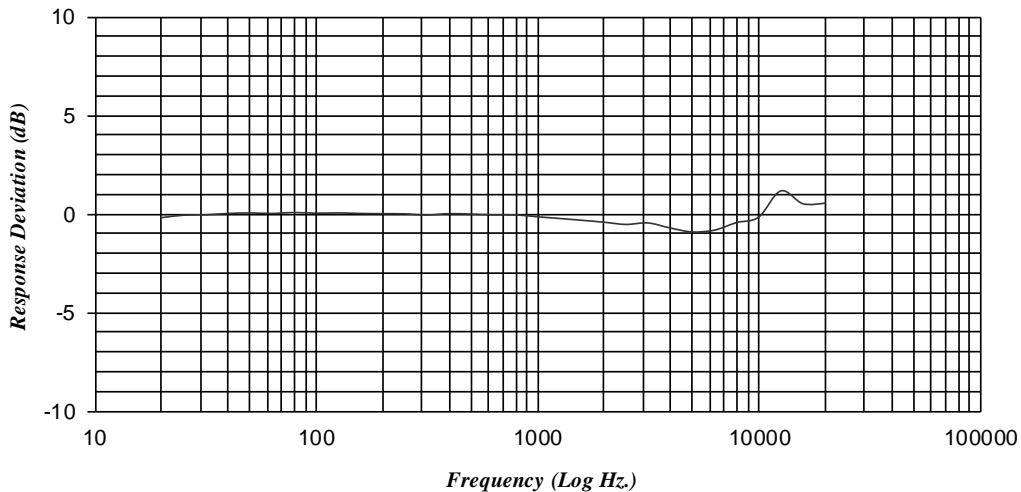

Condition of Unit

As Found: n/a

As Left: New Unit, In Tolerance

Notes

1. This method involves comparing the test unit with a reference microphone in a GRAS 51AB calibrator.
2. Calibration of reference equipment is traceable to one or more of the following National Labs; NIST, PTB or DFM.
3. Calibration is performed in compliance with ISO 9001, ISO 10012-1 and ANSI/NCSL Z540.3.
4. Due to state-of-the-art limitations, 4:1 calibration ratios are not possible on pressure measurement standards, microphones and acoustic calibrators. Calibration ratios for these types of devices are limited to 1:1.
5. See Manufacturer's Specification Sheet for a detailed listing of performance specifications.
6. This certificate shall not be reproduced, except in full, without written approval from PCB Piezotronics, Inc
7. Calibrated per ACS-21.

Technician: Scott Skibniewski

Date: June 10, 2016



Headquarters: 3425 Walden Avenue, Depew, NY 14043

Calibration performed at: 10869 Highway 903, Halifax, NC 27839

Figure 6

~ Calibration Certificate ~

Model Number: 130A24

Serial Number: 41270

Description: ICP® Microphone

Manufacturer: PCB

Method ¹: Back-to-Back Reference

Calibration Data

Sensitivity: 10.4 mV/Pa
-39.7 dB re 1V/Pa

Reference Freq.: 250 Hz
Output Bias: 11.8 VDC

Temperature: 71 °F 22 °C

Relative Humidity: 39 %

Response Plot

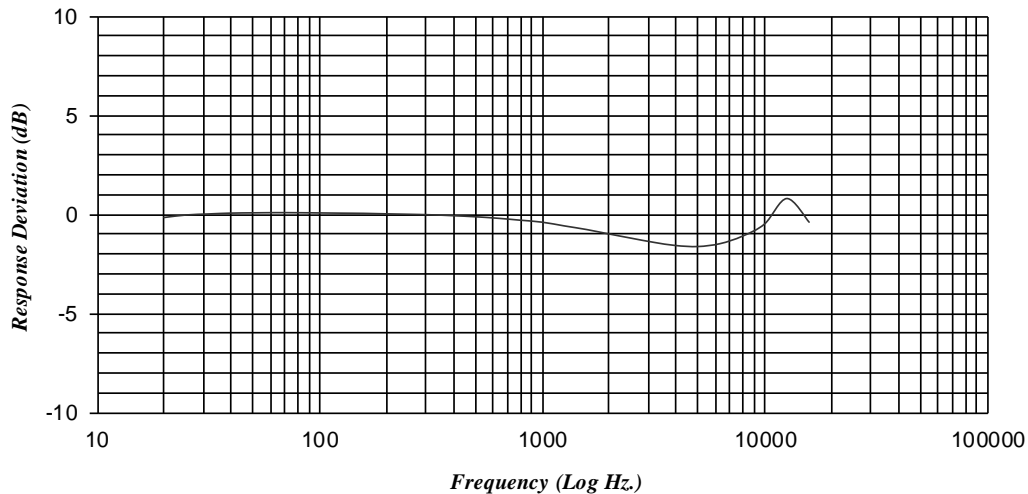

Condition of Unit

As Found: n/a

As Left: New Unit, In Tolerance

Notes

1. This method involves comparing the test unit with a reference microphone in a GRAS 51AB calibrator.
2. Calibration of reference equipment is traceable to one or more of the following National Labs; NIST, PTB or DFM.
3. Calibration is performed in compliance with ISO 9001, ISO 10012-1 and ANSI/NCSL Z540.3.
4. Due to state-of-the-art limitations, 4:1 calibration ratios are not possible on pressure measurement standards, microphones and acoustic calibrators. Calibration ratios for these types of devices are limited to 1:1.
5. See Manufacturer's Specification Sheet for a detailed listing of performance specifications.
6. This certificate shall not be reproduced, except in full, without written approval from PCB Piezotronics, Inc
7. Calibrated per ACS-21.

Technician: William M. Urbanek

Date: April 13, 2015



3425 Walden Avenue
Depew, New York 14043

Figure 7

All 130 series array microphones are designed for use in a free field environment. A free field environment is one without reflections. Anechoic rooms and outdoor spaces without structures are good examples of a free field environment. The free field response is the voltage response with respect to the pressure when exposed to a plane progressive sound wave. A free field microphone has a flat frequency response with respect to any source whose primary direction is collinear with the axis of the microphone.

Calibration of free field microphone occurs at a zero degree angle of incidence. This means that the frequency response reported on the calibration certificate is valid when the microphone is directed straight at the sound source. If the microphone is directed at an angle with respect to the source the response may vary depending on the angle and the frequency of operation.

After completing the system set-up, turn on the the signal conditioner and allow 1 to 2 minutes for the system to stabilize. If the system doesn't appear to be functioning correctly check all system connections and try to isolate and individually check functionality of all system components, or consider replacing system components one at a time. If the system still does not operate properly, consult a PCB Application Engineer.

Under normal conditions, microphones offer a very stable response. However, the microphone output may be affected by harsh environments, such as moisture, dirt, mechanical shock, or other unusual conditions. This may manifest itself in a number of ways, ranging from a loss in frequency range to failure of the built-in microelectronic circuits. To assure sensors characteristics are known PCB[®] recommends that a recalibration cycle be established for each microphone. Customers should determine a calibration cycle best suited for their needs as the cycle is based upon a variety of factors, such as frequency of use, exposure to harsh environmentals, accuracy requirements, trend information obtained from previous calibration records, contractual regulations, and risk associated with incorrect readings. PCB[®] recommends 12 to 24 month calibration intervals but as stated, this interval is at the discretion of the customer and is based on customer needs. It is also best practice to perform verification both before and after each test. PCB's CAL 250 acoustic calibrator (sold separately) is a handheld calibration instrument ideal for field or quick sensor operational evaluation purposes.

6.0 Service

See the supplemental sheet for information on our service, repair and return policies, procedures and instructions. If an unexpected problem arises, call our 24-Hour SensorLineSM (716-684-0001) to discuss your dynamic instrumentation needs with a PCB[®] Application Engineer.

7.0 Warranty

PCB's 130 Series Microphones are covered by a limited warranty against defective material and workmanship. Visit http://www.pcb.com/terms_conditions for a complete statement of our warranty.



3425 Walden Avenue, Depew, NY 14043-2495

E-Mail: info@pcb.com

Website: www.pcb.com

24-hour SensorLineSM: 716-684-0001

Fax: 716-684-0987

Toll-free: 800-828-8840

ISO 9001 CERTIFIED • AS9100 CERTIFIED

In the interest of constant product improvement, specifications are subject to change without notice.

© Copyright PCB Group, Inc. 2016

PCB[®] and ICP[®] are registered trademarks of PCB Group, Inc.
SensorLineSM is a service mark of PCB Group, Inc.

Manual Number: 64548

Manual Revision: NR

ECO# 45478

Printed in the U.S.A.

Model Number 130F21	ICP® ELECTRET ARRAY MICROPHONE	Revision: NR ECN #: 45478
------------------------	---------------------------------------	------------------------------

	<u>ENGLISH</u>	<u>SI</u>	
Performance			
Nominal Microphone Diameter	1/4"	1/4"	
Frequency Response Characteristic(at 0° incidence)	Free-Field	Free-Field	
Frequency Response(± 2 dB)	20 to 10,000 Hz	20 to 10,000 Hz	
Frequency Response(± 3 dB)	10 to 16,000 Hz	10 to 16,000 Hz	
Frequency Response(± 4 dB)	10 to 20,000 Hz	10 to 20,000 Hz	
Phase Match(100 Hz to 3 kHz)	± 3 °	± 3 °	[1]
Phase Match(50 Hz to 5 kHz)	± 5 °	± 5 °	[1]
Phase Match(5 kHz to 10 kHz)	± 10 °	± 10 °	[1]
Sensitivity	45 mV/Pa	45 mV/Pa	
Sensitivity(+/-3)(@ 250 Hz)	-26.9 dB re 1 V/Pa	-26.9 dB re 1 V/Pa	
Inherent Noise(Linear)	29 dB re 20 µPa	29 dB re 20 µPa	[1]
Inherent Noise(A Weighted)	<26 dB(A) re 20 µPa	<26 dB(A) re 20 µPa	
Inherent Noise(A Weighted)	24 dB(A) re 20 µPa	24 dB(A) re 20 µPa	[1]
Dynamic Range(3% Distortion Limit)	>122 dB re 20 µPa	>122 dB re 20 µPa	
TEDS Compliant	Yes	Yes	[2]
Environmental			
Temperature Range(Operating)	+14 to +122 °F	-10 to +50 °C	
Temperature Effect on Output(-10 to +50 °C)	0.7 dB	0.7 dB	[1]
Electrical			
Excitation Voltage	18 to 30 VDC	18 to 30 VDC	
Constant Current Excitation	2 to 20 mA	2 to 20 mA	
Output Bias Voltage	5.5 to 14 VDC	5.5 to 14 VDC	
Output Impedance	<150 Ohm	<150 Ohm	
Physical			
Housing Material	Stainless Steel	Stainless Steel	
Electrical Connector(Output)	10-32 Coaxial Jack	10-32 Coaxial Jack	
Size (Diameter x Length)(overall)	0.28 in x 2.31 in	7.0 mm x 58.6 mm	
Weight	0.30 oz	8.5 gm	[1]

OPTIONAL VERSIONS

Optional versions have identical specifications and accessories as listed for the standard model except where noted below. More than one option may be used.

NOTES:
 [1]Typical.
 [2]TEDS Capable Digital Communication, compliant with IEEE 1451.4
 [3]See PCB Declaration of Conformance PS023 for details.

Entered: LK	Engineer: TP	Sales: MV	Approved: MT	Spec Number:
Date: 6/21/2016	Date: 6/21/2016	Date: 6/21/2016	Date: 6/21/2016	63461



All specifications are at room temperature unless otherwise specified.
 In the interest of constant product improvement, we reserve the right to change specifications without notice.
 ICP® is a registered trademark of PCB Group, Inc.



Phone: 716-684-0001
 Fax: 716-684-0987
 E-Mail: info@pcb.com

63459

PCB Piezotronics Inc. claims proprietary rights in the information disclosed hereon. Neither it nor any reproduction thereof will be disclosed to others without the written consent of PCB Piezotronics Inc.

REVISIONS		
REV	DESCRIPTION	DIN
NR	RELEASED TO DRAFTING	45478

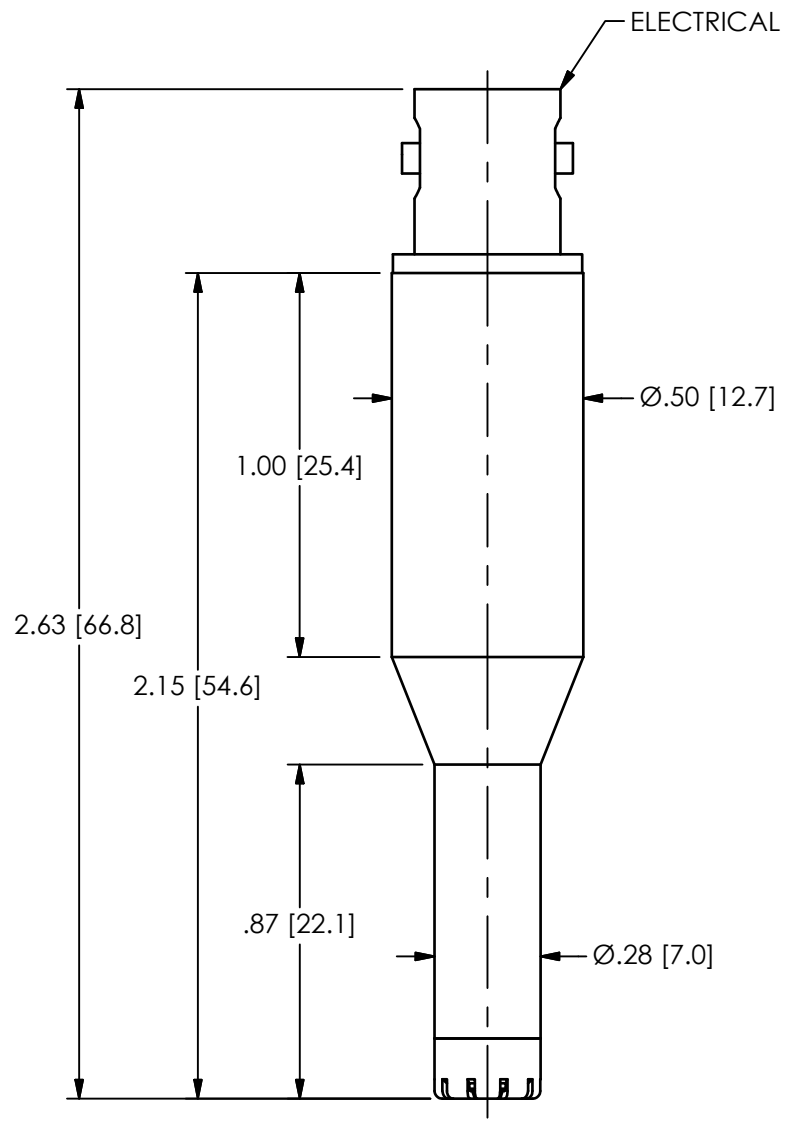

MODEL 130F20

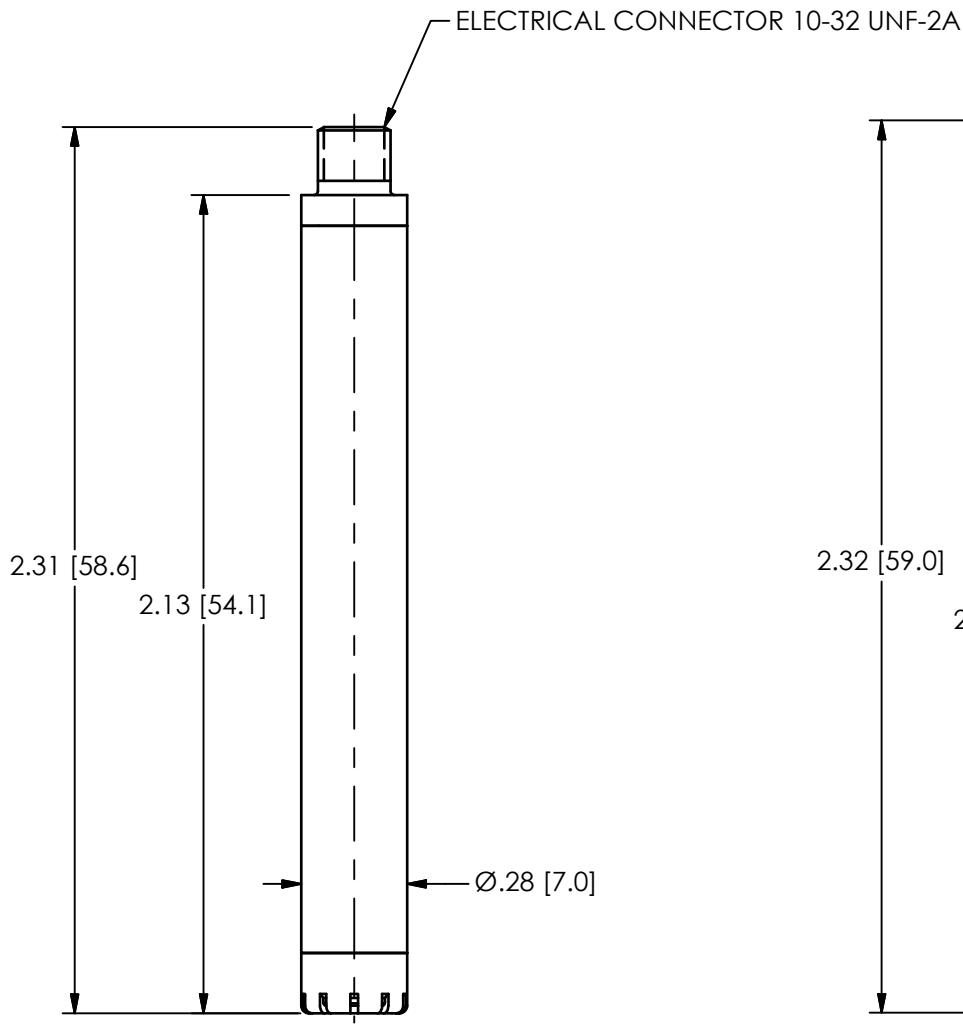

MODEL 130F21

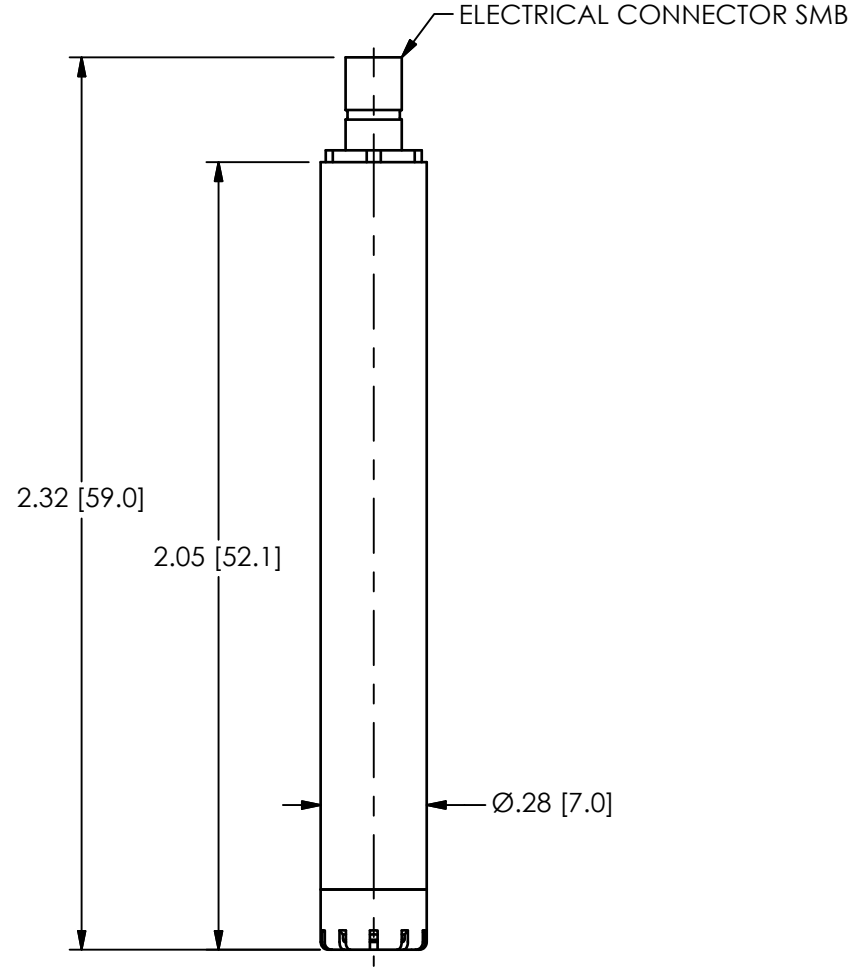

MODEL 130F22

UNLESS OTHERWISE SPECIFIED TOLERANCES ARE:		DRAWN		CHECKED		ENGINEER	
DIMENSIONS IN INCHES	DIMENSIONS IN MILLIMETERS [IN BRACKETS]	KRM	6/15/16	ECB	6/15/16	NJL	6/15/16
DECIMALS XX ±.03 XXX ±.010	DECIMALS X ±0.8 XX ±0.25	TITLE OUTLINE DRAWING MODEL 130F SERIES ICP MICROPHONE					
ANGLES ± 2 DEGREES	ANGLES ± 2 DEGREES						
FILLETS AND RADII .003 - .005	FILLETS AND RADII 0.07 - 0.13	CODE IDENT. NO. 52681		DWG. NO. 63459		3425 WALDEN AVE. DEPEW, NY 14043 (716) 684-0001 E-MAIL: sales@pcb.com	
		SCALE: 2X		SHEET 1 OF 1			



3425 WALDEN AVE. DEPEW, NY 14043
(716) 684-0001 E-MAIL: sales@pcb.com

CODE IDENT. NO. 52681
DWG. NO. 63459

SCALE: 2X SHEET 1 OF 1