



**Model 119B11**  
**Charge Output Pressure Sensor**  
**Installation and Operating Manual**

**For assistance with the operation of this product,  
contact PCB Piezotronics, Inc.**

**Toll-free: 800-828-8840**  
**24-hour SensorLine: 716-684-0001**  
**Fax: 716-684-0987**  
**E-mail: [info@pcb.com](mailto:info@pcb.com)**  
**Web: [www.pcb.com](http://www.pcb.com)**



**The information contained in this document supersedes all similar information that may be found elsewhere in this manual.**

**Total Customer Satisfaction** – PCB Piezotronics guarantees Total Customer Satisfaction. If, at any time, for any reason, you are not completely satisfied with any PCB product, PCB will repair, replace, or exchange it at no charge. You may also choose to have your purchase price refunded in lieu of the repair, replacement, or exchange of the product.

**Service** – Due to the sophisticated nature of the sensors and associated instrumentation provided by PCB Piezotronics, user servicing or repair is not recommended and, if attempted, may void the factory warranty. Routine maintenance, such as the cleaning of electrical connectors, housings, and mounting surfaces with solutions and techniques that will not harm the physical material of construction, is acceptable. Caution should be observed to insure that liquids are not permitted to migrate into devices that are not hermetically sealed. Such devices should only be wiped with a dampened cloth and never submerged or have liquids poured upon them.

**Repair** – In the event that equipment becomes damaged or ceases to operate, arrangements should be made to return the equipment to PCB Piezotronics for repair. User servicing or repair is not recommended and, if attempted, may void the factory warranty.

**Calibration** – Routine calibration of sensors and associated instrumentation is

recommended as this helps build confidence in measurement accuracy and acquired data. Equipment calibration cycles are typically established by the users own quality regimen. When in doubt about a calibration cycle, a good “rule of thumb” is to recalibrate on an annual basis. It is also good practice to recalibrate after exposure to any severe temperature extreme, shock, load, or other environmental influence, or prior to any critical test.

PCB Piezotronics maintains an ISO-9001 certified metrology laboratory and offers calibration services, which are accredited by A2LA to ISO/IEC 17025, with full traceability to N.I.S.T. In addition to the normally supplied calibration, special testing is also available, such as: sensitivity at elevated or cryogenic temperatures, phase response, extended high or low frequency response, extended range, leak testing, hydrostatic pressure testing, and others. For information on standard recalibration services or special testing, contact your local PCB Piezotronics distributor, sales representative, or factory customer service representative.

**Returning Equipment** – *Following these procedures will insure that your returned materials are handled in the most expedient manner.* Before returning any equipment to PCB Piezotronics, contact your local distributor, sales representative, or factory customer service representative to obtain a Return

Materials Authorization (RMA) Number. This RMA number should be clearly marked on the outside of all package(s) and on the packing list(s) accompanying the shipment. A detailed account of the nature of the problem(s) being experienced with the equipment should also be included inside the package(s) containing any returned materials.

A Purchase Order, included with the returned materials, will expedite the turn-around of serviced equipment. It is recommended to include authorization on the Purchase Order for PCB to proceed with any repairs, as long as they do not exceed 50% of the replacement cost of the returned item(s). PCB will provide a price quotation or replacement recommendation for any item whose repair costs would exceed 50% of replacement cost, or any item that is not economically feasible to repair. For routine calibration services, the Purchase Order should include authorization to proceed and return at current pricing, which can be obtained from a factory customer service representative.

**Warranty** – All equipment and repair services provided by PCB Piezotronics, Inc. are covered by a limited warranty against defective material and workmanship for a period of one year from date of original purchase. Contact

PCB for a complete statement of our warranty. Expendable items, such as batteries and mounting hardware, are not covered by warranty. Mechanical damage to equipment due to improper use is not covered by warranty. Electronic circuitry failure caused by the introduction of unregulated or improper excitation power or electrostatic discharge is not covered by warranty.

**Contact Information** – International customers should direct all inquiries to their local distributor or sales office. A complete list of distributors and offices can be found at [www.pcb.com](http://www.pcb.com). Customers within the United States may contact their local sales representative or a factory customer service representative. A complete list of sales representatives can be found at [www.pcb.com](http://www.pcb.com). Toll-free telephone numbers for a factory customer service representative, in the division responsible for this product, can be found on the title page at the front of this manual. Our ship to address and general contact numbers are:

PCB Piezotronics, Inc.  
3425 Walden Ave.  
Depew, NY 14043 USA  
Toll-free: (800) 828-8840  
24-hour SensorLine<sup>SM</sup>: (716) 684-0001  
Website: [www.pcb.com](http://www.pcb.com)  
E-mail: [info@pcb.com](mailto:info@pcb.com)

# OPERATION MANUAL FOR QUARTZ PRESSURE SENSOR Model 119B & 119B02, B11 & B12

## 1.0 INTRODUCTION

PCB® Series 119B are unique sensors featuring 100,000 psi capability, acceleration compensation and a rugged one piece integral machined diaphragm. The Models 119B and 119B02 are rated to 80,000 and 120,000 psi, respectively. The 119B11 and 119B12 are the same as the B01 and B02, but they have floating clamp nuts instead of integral mounting threads on the body.

These sensors are primarily for measuring ballistic chamber pressures during R & D and production testing of ammunition. They may also be used for explosive air blast and other high pressure measurements in extreme shock environments where ultra-fast, micro-second response is required.

The shoulder seal design features a one-piece diaphragm machined integral with the housing for ruggedness. A ceramic coating is applied to the diaphragm to minimize flash temperature effects.

The charge output from the 119B series is negative, making them compatible with inverting type charge amplifiers.

A positive output model is available for use with non-inverting amplifiers such as the PCB® miniature source follower Series 402A.

## 2.0 DESCRIPTION

Series 119B contains an acceleration compensated quartz element with an integral seismic mass that counteracts the acceleration effects of the end piece and diaphragm and acts to extend the frequency characteristics and enhance the transient response of the sensor.

The machined diaphragm is made from maraging steel, selected because of its high strength and durability.

As shown in Figure 1, four quartz crystals are employed, two for acceleration compensation and two for active production of charge when acted upon by pressure. The short, rigid element and stiff diaphragm give the Series 119B a 400 kHz natural frequency and good linearity, even below 1000 psi.

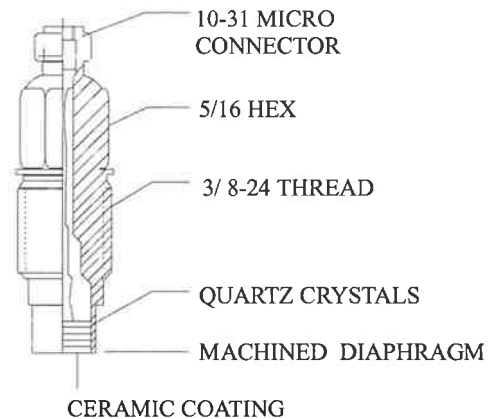

Figure 1  
Series 119B Internal Construction

## 3.0 INSTALLATION

The Series 119B, with 3/8-24 (M10 x 1.0 for metric) thread and flush diaphragm design also mount in existing ports for PCB® Series 108, 109, 118, 119, 165 and 167 sensors.

**Caution:** Extra care should be exercised to avoid bottoming in the mounting hole when recess mounted or when mounting into existing ports as the sensor diaphragm may be damaged.

Prepare mounting ports in accordance with instructions given on the installation drawing provided in this manual. Use good machining practice paying particular attention to the sealing surface, keeping it free from tool chatter marks, nicks and other imperfections that could preclude a pressure seal. Use of an optional PCB Model 040B20 SAE thread or Model 040B21 metric tool kit is recommended.

Install the sensor using only one of the seals provided and use a torque wrench to monitor the mounting torque value specified on the installation drawing. It is recommended to replace the seal each time the sensor is re-installed.

For fastest response time, flush mounting should be used to avoid passage resonances and attenuation of rise time.

### 3.1 MOUNTING IN EXISTING RECESSED PORTS

Before installing the sensor in previously used mounting ports, clean out the residue left by previous tests, as shown in Figure 2 below.

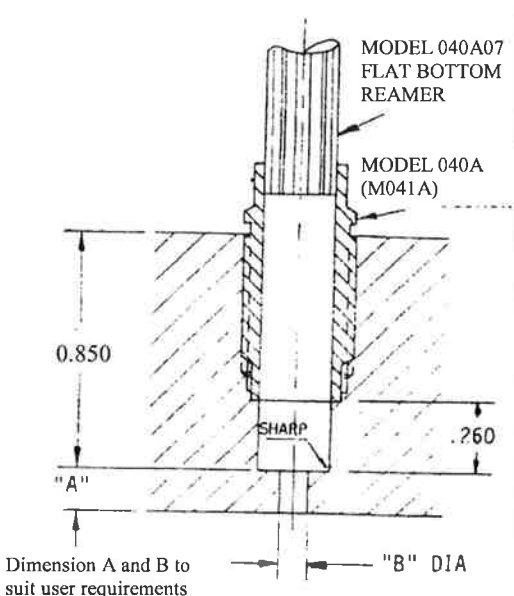

**Figure 2  
Recessed Mount Seal Surface Cleaning**

The ports can be cleaned by hand-reaming the 0.252 inch (6.4 mm) diameter hole using a PCB® Model 040A07 (Part Nr. 100-8075-10 for metric mount) end cutting reamer (or equivalent). The reamer is guided using Reamer Bushing Model 040A for SAE threaded mounts and M041A for metric mounts.

If waveform distortion occurs during prolonged testing, remove the sensor and clean the residue as illustrated above.

If the shoulder seal requires re-machining for proper sealing after prolonged use in a recessed mount, the installation drawing should be reviewed as the 0.252 inch (6.4 mm) diameter hole must also be deepened accordingly. If the 0.252 inch (6.4 mm) hole is not re-machined, the sensor may bottom when installed.

### 3.2 PREPARING NEW MOUNTING PORTS

Use good machining practices when preparing the mounting port, paying particular attention to keeping the seal surface free from tool chatter marks.

*Note: It is important that this surface be perfectly smooth and free from nicks or other discontinuities. These cause leaks at high pressures.*

### 3.3 RECESSED MOUNT

Recessed mounting protects the sensor diaphragm from the effects of high flash temperatures and particle impingement from blast effects, prolonging sensor life.

The recommended range of passage diameters is from 0.090 to 0.125 inch (2.29 to 3.18 mm).

The response limitation of the recessed mounting technique is determined by the length of the passage.

The passage behaves like an under-damped second order system, with a resonant frequency determined by its length. The length may have a limiting effect on pressure pulse rise time and cause passage ringing in cases where the passage is too long.

The following relationship estimates this resonant frequency ( $f_r$ ):

$$f_r = \frac{V}{4L} \quad (\text{Hz}) \quad (\text{EQ. 1})$$

Where:  $f_r$  = Resonant frequency of passage (Hz)

$V$  = Velocity of sound in air (ft/sec)

$L$  = linear length of column plus 40% of the diameter (ft)

For air at room temp, (EQ. 1) becomes:

$$f_r = \frac{13392}{L} \quad (\text{EQ. 2})$$

Where:  $L$  = Effective passage length (in.)

# OPERATION MANUAL FOR QUARTZ PRESSURE SENSOR Model 119B & 119B02, B11 & B12

The natural frequency estimate and approximate fastest Pressure step rise time for various length passages is shown in the following chart. (Medium, air at 25 °C).

PASSAGE LENGTH (in)	PASSAGE RESONANCE (kHz)	APPROX. FASTEST PULSE RISE TIME (uSec)
.050	66	5
.100	33	10
.200	16.5	20
.50	6.6	50
1.0	3.3	100

Resonant frequencies measured during testing may differ slightly from the chart values. Discrepancies may be caused by variations in the velocity of sound in air resulting from fluctuations in air temperature and pressure.

If possible, keep passage lengths below 0.10 in (2.54 mm) for best results in most ballistic applications, especially when measuring port and case mouth pressures.

For best frequency matching of passage to diaphragm, maintain the 0.010 inch (0.254 mm) clearance shown in Figure 3 below.

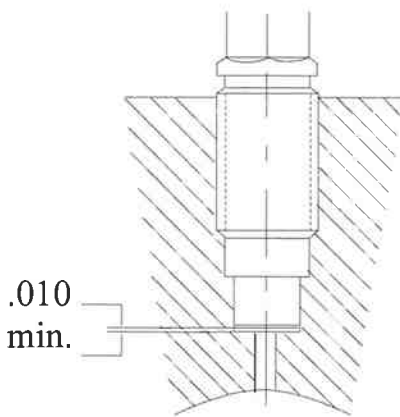

**Figure 3**

### 3.4 FLUSH MOUNT

When flush mounting, there is no reduced area passage from the sensor diaphragm to the test chamber; rather the sensor diaphragm is mounted flush with (or slightly recessed from) the inside surface of the test chamber.

**Important:** Use this type of installation only if space or rise time considerations preclude the use of the recessed installation technique. In severe pyrotechnic environments, sensor life may be severely limited with flush installation.

### 3.5 FLASH TEMPERATURE EFFECTS

The sensors are manufactured with a heat-resistance ceramic coating on the diaphragm. The ceramic coating on the diaphragm of these sensors should render the flash thermal effect insignificant in most cases, especially when recess mounted.

In cases where flash temperatures such as those generated by blasts and shock fronts are present, it may be necessary to apply additional thermally insulating material to minimize signals generated by these effects. Such signals are usually longer term and will usually show up as baseline shift long after the event to be measured has passed.

#### Flush Mounting:

A silicone rubber coating approximately 0.010 inch (0.254 mm) thick has been proven effective in many field applications. G.E. type 106 RTV is recommended; available from PCB® as Model 065A67.

Black vinyl electrical tape has also been found to be an effective ablative material in many cases. One or more layers may be used across the diaphragm as needed.

#### Recessed Mounting:

If increased protection from flash thermal effects is required, the recess mount passage can be filled with silicone grease (DC-4 or equivalent).

### 3.6 INSTALLING CABLES

Use only low noise coaxial cable (PCB® Series 003 or equivalent), to connect the sensor to the charge amplifier, in-line voltage amplifier, or other high

**OPERATION MANUAL FOR  
QUARTZ PRESSURE SENSOR  
Model 119B & 119B02, B11 & B12**

input impedance readout instrument. Protect the ultra-high impedance connection against moisture contamination with shrink tubing or other suitable means. It is good practice to support sensor cables by tying them to rigid structures, to prevent excessive motion which can generate noise and shorten cable life. Allow an adequate strain relief loop.

Figures 4 and 5 illustrate typical circuit connections.

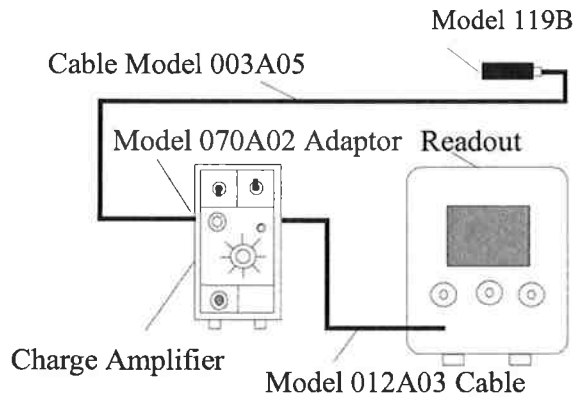

**Figure 4  
Charge Amplifier Measuring Chain**

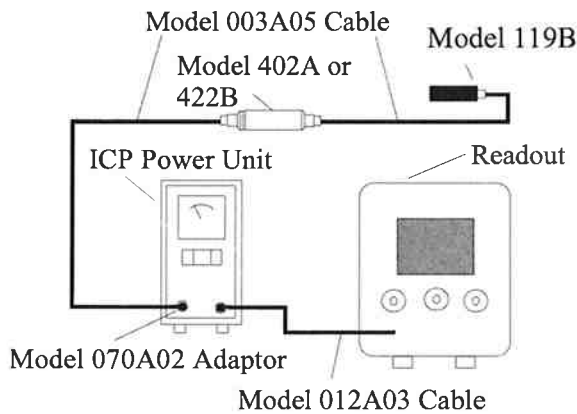

**Figure 5  
Source Follower Measuring Chain**

## 4.0 OPERATION

Most test set-ups will include Series 119B sensors coupled with electrostatic charge amplifiers, such as PCB® Model 443B02.

*Note:* Keep the charge amplifier input cable as short as practical. Electrical noise at the output of any charge amplifier is directly related to input cable length (capacitance).

Depress the ground button of the charge amplifier and adjust electrical zero if necessary. Range the amplifier as required, to give the necessary full-scale voltage.

For normal, drift-free operation, switch charge amplifier time constant selector to "medium" or "short" during use.

## 4.1 POLARITY

Since most charge amplifiers are inverting amplifiers, Series 119B sensors are designed to produce a negative-going charge as pressure increases on the diaphragm.

Special positive output versions are available for use with non-inverting ICP® source follower amplifiers; Series 402A.

## 5.0 CALIBRATION

Series 119B sensors are supplied with a calibration certificate from the factory. Recalibration services are provided at the factory for a nominal charge.

They can be calibrated using quasi-static hydraulic techniques such as dead weight testers or by comparison with a strain gage reference.

Use the charge amplifier on "long time constant" and allow the sensor to thermally stabilize before attempting to calibrate.

*Note: Do not attempt to use a charge amplifier which has less than a 5000 second time constant in the "long time constant" position.*

Several charge amplifiers are specially designed for use with ceramic accelerometers measuring higher frequencies. In general, this type of charge amplifier is not suitable for calibration of quartz pressure sensors by quasi-static means.

## 6.0 MAINTENANCE

Regular inspection of the sensor diaphragm, threads and connector is good practice.

The only maintenance required on Series 119B sensors is cleaning of the connector to restore insulation resistance.

During use in damp environments or after a period of storage, the insulation resistance of these sensors may degrade ( $10^{12}$  ohms is normal).

To restore insulation, wipe the connector end with a clean cloth or paper towel dipped in Lenium® or an equivalent solvent, followed by an isopropyl alcohol wipe. Bake the sensor in a 250 °F (120 °C) oven for several hours. A vacuum oven, if available, will speed the process.

Contact the factory for further assistance if the insulation resistance cannot be restored.



Model Number

119B11

## CHARGE OUTPUT PRESSURE SENSOR

Revision: D

ECN #: 27048

**Performance**

	<b>ENGLISH</b>	<b>SI</b>
Sensitivity(± 15 %)	0.25 pC/psi	0.036 pC/kPa
Measurement Range	0 to 80,000 psi	0 to 552,000 kPa
Maximum Pressure	100 kpsi	690,000 kPa
Resolution	≤ 1 psi	≤ 7 kPa
Resonant Frequency	≥ 400 kHz	≥ 400 kHz
Rise Time(Reflected)	≤ 2 μ sec	≤ 2 μ sec
Non-Linearity	≤ 2 % FS	≤ 2 % FS

**Environmental**

Acceleration Sensitivity	≤ 0.02 psi/g	≤ 0.015 kPa/(m/s <sup>2</sup> )
Temperature Range(Operating)	-300 to 400 °F	-184 to 204 °C
Temperature Coefficient of Sensitivity	≤ 0.07 %/°F	≤ 0.126 %/°C
Maximum Flash Temperature	4000 °F	2204 °C
Maximum Vibration	2000 g pk	19,614 m/s <sup>2</sup> pk
Maximum Shock	50,000 g pk	490,330 m/s <sup>2</sup> pk

**Electrical**

Output Polarity(Positive Pressure)	Negative	Negative
Capacitance	20 pF	20 pF
Insulation Resistance(at room temp)	≥ 1E12 ohm	≥ 1E12 ohm

**Physical**

Sensing Element	Quartz	Quartz
Housing Material	C-300	C-300
Diaphragm	C-300	C-300
Sealing	Epoxy	Epoxy
Electrical Connector	10-32 Coaxial Jack	10-32 Coaxial Jack
Weight	.5 oz	14 gm

All specifications are at room temperature unless otherwise specified.

In the interest of constant product improvement, we reserve the right to change specifications without notice.

ICP® is a registered trademark of PCB Group, Inc.

**OPTIONAL VERSIONS**

Optional versions have identical specifications and accessories as listed for the standard model except where noted below. More than one option may be used.

<b>H</b> - Hermetic Seal		
Housing Material	17-4 Stainless Steel	17-4 Stainless Steel
Maximum Shock	20,000 g pk	196,200
Sealing	Welded Hermetic	Welded Hermetic

**M** - Metric Mount**P** - Positive Output Polarity**W** - Water Resistant Cable**NOTES:**

- [1] Nominal.  
 [2] Zero-based, least-squares, straight line method.  
 [3] Ceramic coated.

**SUPPLIED ACCESSORIES:**

Model 065A06 Seal ring 0.318" OD x 0.250" ID x 0.010" thk 316L SS material (3)

Entered: BLS	Engineer: RF	Sales: DPC	Approved: RF	Spec Number:
Date: 8-11-07	Date: 8-7-07	Date: 8-7-07	Date: 8-7-07	20687

**PCB PIEZOTRONICS™**  
 PRESSURE DIVISION  
 3425 Walden Avenue, Depew, NY 14043

Phone: 716-684-0001  
 Fax: 716-686-9129  
 E-Mail: pressure@pcb.com

PCB Piezotronics Inc. claims proprietary rights in the information disclosed hereon. Neither it nor any reproduction thereof will be disclosed to others without the written consent of PCB Piezotronics Inc.

REVISIONS		
REV	DESCRIPTION	DIN
E	UPDATED NOTE 2	37802

20671

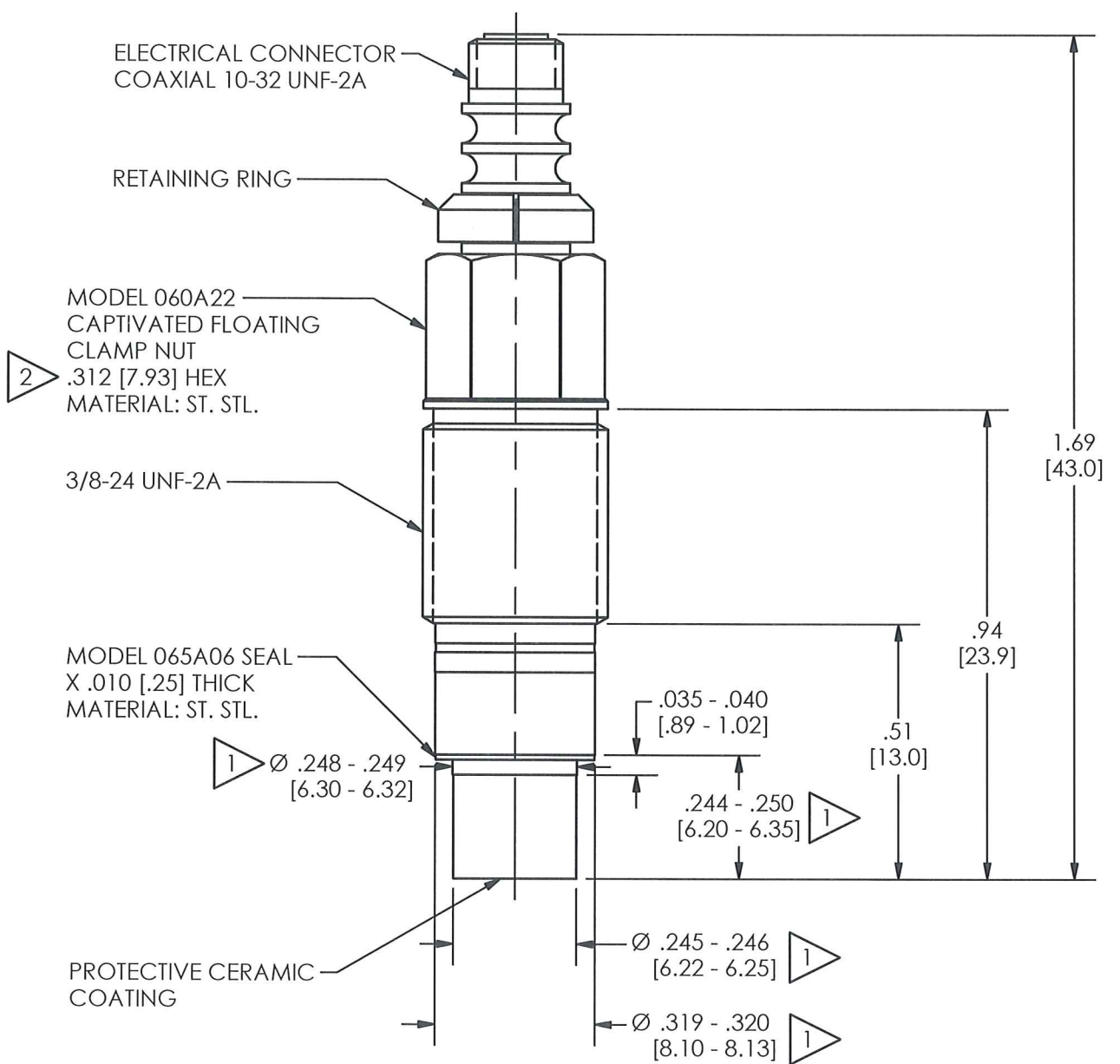

FLUSH INSTALLATION

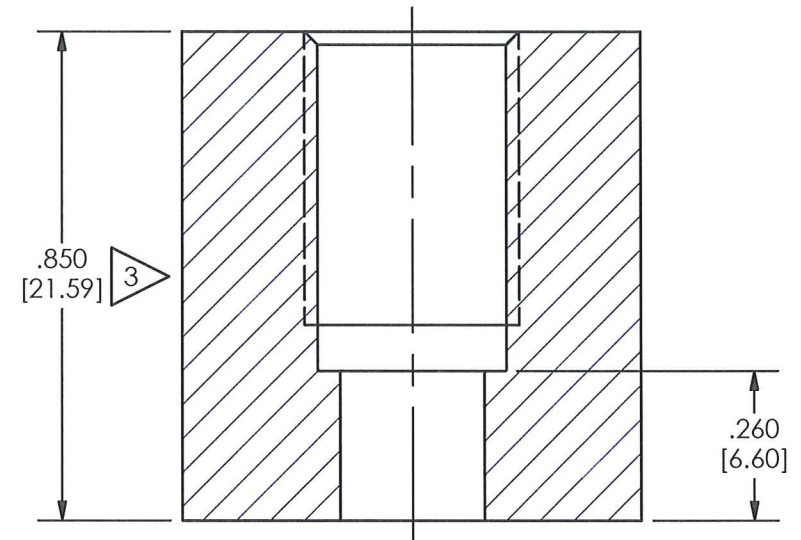

RECESSED INSTALLATION

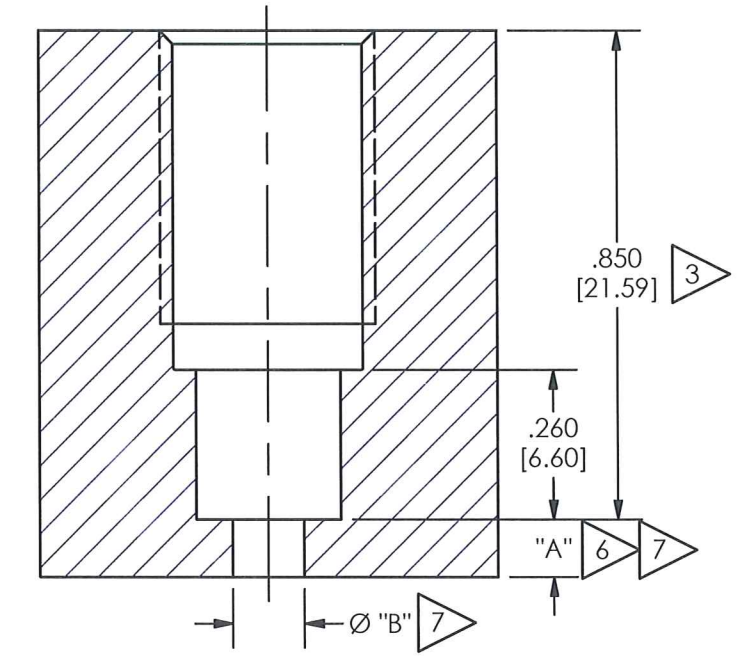

MOUNTING HOLE DIMENSIONS

- 3 5 Ø.252 ± .001 [6.40 ± .03] THRU
- 4 5 L ⌀.332 ± .001 [8.43 ± .03] (∇.590 [14.99])
- 8 3/8-24 UNF-2B ∇.510 [12.95]

MOUNTING HOLE DIMENSIONS

- 3 5 L ⌀.252 ± .001 [6.40 ± .03] ∇.850 [21.59]
- 4 5 L ⌀.332 ± .001 [8.43 ± .03] (∇.590 [14.99])
- 8 3/8-24 UNF-2B ∇.510 [12.95]

- 8 CAUTION: DO NOT TOUCH SEAL SURFACE WITH TAP WHEN TAPPING HOLE.
- 7 DIMENSION "A" & "B" TO SUIT USER REQUIREMENTS.
- 6 KEEP "A" AS SHORT AS POSSIBLE, SEE OPERATING GUIDE FOR OPTIMUM PASSAGE LENGTH.
- 5 THESE DIAMETERS TO BE CONCENTRIC WITHIN .001 [.03] TIR.
- 4 SEAL SURFACE SHOULD BE FLAT AND FREE OF TOOL MARKS WITH A MINIMUM 63[1.6] FINISH FOR BEST RESULTS.
- 3 DIMENSIONS SHOWN ARE FOR .850 [21.59] WALL THICKNESS. COUNTERBORE FOR THICKER WALL.
- 2 RECOMMENDED MOUNTING TORQUE ON .312 [7.93] HEX: 27-32 FT-LB [36-43 N-M].
- 1 MATERIAL: C-300 MARAGING STEEL.

UNLESS OTHERWISE SPECIFIED TOLERANCES ARE:		DRAWN	CHECKED	ENGINEER	 3425 WALDEN AVE. DEPEW, NY 14043 (716) 684-0001 E-MAIL: sales@pcb.com
DIMENSIONS IN INCHES	DIMENSIONS IN MILLIMETERS [IN BRACKETS]	JDM	12/6/11	NJL	
DECIMALS XX ±.01 XXX ±.005	DECIMALS X ± 0.3 XX ± 0.13	TITLE		INSTALLATION DRAWING MODEL 119B11, B12 PRESSURE SENSOR	
ANGLES ± 2 DEGREES	ANGLES ± 2 DEGREES	CODE IDENT. NO. 52681		DWG. NO. 20671	
FILLETS AND RADII .003 - .005	FILLETS AND RADII 0.07 - 0.13	SCALE: 3X		SHEET 1 OF 1	