



**Model 118A02**  
**Charge Output Pressure Sensor**  
**Installation and Operating Manual**

**For assistance with the operation of this product,  
contact PCB Piezotronics, Inc.**

**Toll-free: 800-828-8840**  
**24-hour SensorLine: 716-684-0001**  
**Fax: 716-684-0987**  
**E-mail: [info@pcb.com](mailto:info@pcb.com)**  
**Web: [www.pcb.com](http://www.pcb.com)**



**The information contained in this document supersedes all similar information that may be found elsewhere in this manual.**

**Total Customer Satisfaction** – PCB Piezotronics guarantees Total Customer Satisfaction. If, at any time, for any reason, you are not completely satisfied with any PCB product, PCB will repair, replace, or exchange it at no charge. You may also choose to have your purchase price refunded in lieu of the repair, replacement, or exchange of the product.

**Service** – Due to the sophisticated nature of the sensors and associated instrumentation provided by PCB Piezotronics, user servicing or repair is not recommended and, if attempted, may void the factory warranty. Routine maintenance, such as the cleaning of electrical connectors, housings, and mounting surfaces with solutions and techniques that will not harm the physical material of construction, is acceptable. Caution should be observed to insure that liquids are not permitted to migrate into devices that are not hermetically sealed. Such devices should only be wiped with a dampened cloth and never submerged or have liquids poured upon them.

**Repair** – In the event that equipment becomes damaged or ceases to operate, arrangements should be made to return the equipment to PCB Piezotronics for repair. User servicing or repair is not recommended and, if attempted, may void the factory warranty.

**Calibration** – Routine calibration of sensors and associated instrumentation is

recommended as this helps build confidence in measurement accuracy and acquired data. Equipment calibration cycles are typically established by the users own quality regimen. When in doubt about a calibration cycle, a good “rule of thumb” is to recalibrate on an annual basis. It is also good practice to recalibrate after exposure to any severe temperature extreme, shock, load, or other environmental influence, or prior to any critical test.

PCB Piezotronics maintains an ISO-9001 certified metrology laboratory and offers calibration services, which are accredited by A2LA to ISO/IEC 17025, with full traceability to N.I.S.T. In addition to the normally supplied calibration, special testing is also available, such as: sensitivity at elevated or cryogenic temperatures, phase response, extended high or low frequency response, extended range, leak testing, hydrostatic pressure testing, and others. For information on standard recalibration services or special testing, contact your local PCB Piezotronics distributor, sales representative, or factory customer service representative.

**Returning Equipment** – *Following these procedures will insure that your returned materials are handled in the most expedient manner.* Before returning any equipment to PCB Piezotronics, contact your local distributor, sales representative, or factory customer service representative to obtain a Return

Materials Authorization (RMA) Number. This RMA number should be clearly marked on the outside of all package(s) and on the packing list(s) accompanying the shipment. A detailed account of the nature of the problem(s) being experienced with the equipment should also be included inside the package(s) containing any returned materials.

A Purchase Order, included with the returned materials, will expedite the turn-around of serviced equipment. It is recommended to include authorization on the Purchase Order for PCB to proceed with any repairs, as long as they do not exceed 50% of the replacement cost of the returned item(s). PCB will provide a price quotation or replacement recommendation for any item whose repair costs would exceed 50% of replacement cost, or any item that is not economically feasible to repair. For routine calibration services, the Purchase Order should include authorization to proceed and return at current pricing, which can be obtained from a factory customer service representative.

**Warranty** – All equipment and repair services provided by PCB Piezotronics, Inc. are covered by a limited warranty against defective material and workmanship for a period of one year from date of original purchase. Contact

PCB for a complete statement of our warranty. Expendable items, such as batteries and mounting hardware, are not covered by warranty. Mechanical damage to equipment due to improper use is not covered by warranty. Electronic circuitry failure caused by the introduction of unregulated or improper excitation power or electrostatic discharge is not covered by warranty.

**Contact Information** – International customers should direct all inquiries to their local distributor or sales office. A complete list of distributors and offices can be found at [www.pcb.com](http://www.pcb.com). Customers within the United States may contact their local sales representative or a factory customer service representative. A complete list of sales representatives can be found at [www.pcb.com](http://www.pcb.com). Toll-free telephone numbers for a factory customer service representative, in the division responsible for this product, can be found on the title page at the front of this manual. Our ship to address and general contact numbers are:

PCB Piezotronics, Inc.  
3425 Walden Ave.  
Depew, NY 14043 USA  
Toll-free: (800) 828-8840  
24-hour SensorLine<sup>SM</sup>: (716) 684-0001  
Website: [www.pcb.com](http://www.pcb.com)  
E-mail: [info@pcb.com](mailto:info@pcb.com)

## 1.0 INTRODUCTION

The Series 118 Pressure Sensor was developed primarily for measuring ballistics chamber pressures during R & D and production testing of ammunition.

Shoulder Seal designs feature a one-piece diaphragm machined integral with the housing for ruggedness. A ceramic coating is applied to the diaphragm to minimize flash temperature effects.

Conical End Seals are designed to be recess mounted for thermal protection. See Sections 3.3 and 3.5 for further recommendations on the use of End Seal mounted sensors.

The piezoelectric element utilizes quartz crystals to convert instantaneous pressure changes to an analogous electrostatic charge.

The short, rigid element and stiff diaphragm give the Series 118 a 300,000 Hz natural frequency and good linearity, even below 1000 psi.

## 3.0 INSTALLATION

The Series 118 mounts directly into existing ports machined for PCB Series 119, 109, 108, and 167.

Unlike conventional diaphragm type sensors, the Series 118 is pressure sensitive over the entire frontal area.

For this reason, extra care should be exercised to avoid bottoming in the mounting hole when recess mounted and when mounting into existing mounting ports.

A torque wrench should be used to monitor the mounting torque value when installing the Series 118. The recommended range is given on the installation drawing for each model.

It is a good practice to replace the seal each time the sensor is re-installed.

### 3.1 MOUNTING IN EXISTING RECESSED PORTS

Before installing the sensor in previously used mounting ports, clean out the residue left by previous tests, as shown in figure below.

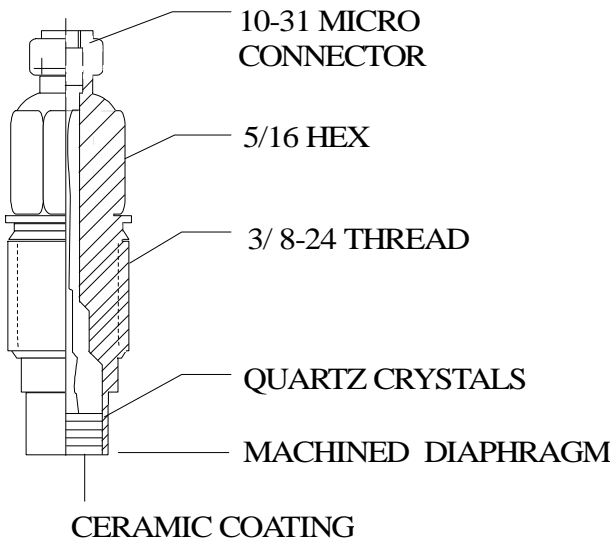
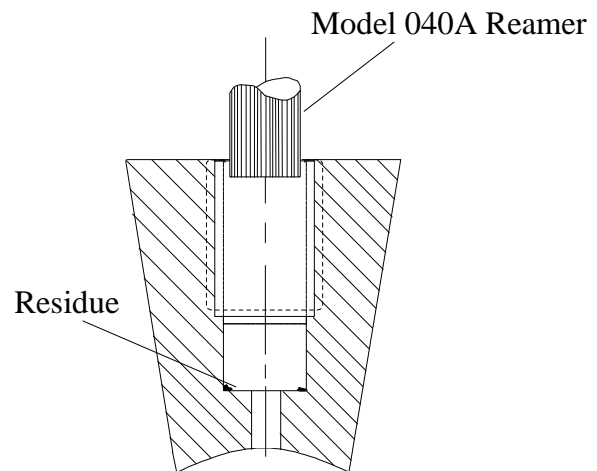

**Figure 1**

## 2.0 DESCRIPTION

The machined diaphragm is made from maraging steel, selected because of its high strength and durability.

The 3/8-24 (M10 x 1.0 for metric units) thread and flush diaphragm design are a standard design that provides direct interchangeability with existing welded, diaphragm type piezoelectric sensors.



**Figure 2**

The ports can be cleaned by hand-reaming the 1/4" (.0635 mm) diameter hole using a PCB Model 040A end cutting reamer (or equivalent), for SAE threaded mounts.

If waveform distortion occurs during prolonged testing, remove the sensor and residue as illustrated.

Should the seal surface require re-machining for clean up after prolonged use, deepen the 1/4" diameter hole by the same amount. If the hole is not re-machined, the sensor may bottom when installed.

### 3.2 PREPARING NEW MOUNTING PORTS

Use good machining practices when preparing the mounting port, paying particular attention to keeping the seal surface free from tool chatter marks.

NOTE: It is important that this surface be perfectly smooth and free from nicks or other discontinuities. These cause leaks at high pressures.

### 3.3 RECESSED MOUNT

Recessed mounting protects the sensor diaphragm from the effects of high flash temperatures and particle impingement from blast effects, prolonging sensor life.

The recommended range of passage diameters is .090 to .125 inch (2.29 to 3.18 mm) diameter.

The response limitation of the recessed mounting technique is determined by the length of the passage.

The passage behaves like an underdamped second order system, with a resonant frequency determined by its length. The length may have a limiting effect on pressure pulse rise time and cause passage ringing in cases where the passage is too long.

The following relationship determines this resonant frequency ( $f_r$ ):

$$f_r = \frac{V}{4L} \quad (\text{Hz}) \quad (\text{EQ. 1})$$

Where:  $f_r$  = Resonant frequency of passage (Hz)

$v$  = Velocity of sound in air (ft/sec)

$L$  = Length of column (ft)

For air at room temp, (EQ. 1) becomes:

$$f_r = \frac{3300}{L} \quad (\text{EQ. 2})$$

Where:  $L$  = Passage length (in.)

The natural frequency and approximate fastest pressure step rise time for various length passages is shown in the following chart. (Medium, air at 25 °C).

PASSAGE LENGTH (in)	PASSAGE RESONANCE (kHz)	APPROX. FASTEST PULSE RISE TIME (uSec)
.050	66	5
.100	33	10
.200	16.5	20
.50	6.6	50
1.0	3.3	100

Resonant frequencies measured during testing may differ slightly from the chart values. Discrepancies may be caused by variations in the velocity of sound in air resulting from fluctuations in air temperature and pressure.

If possible, keep passage lengths below .10 in. for best results in most ballistic applications, especially when measuring port and casemouth pressures.

For best matching of passage to diaphragm, maintain the .010 clearance ahead of the diaphragm, as shown in figure 3.

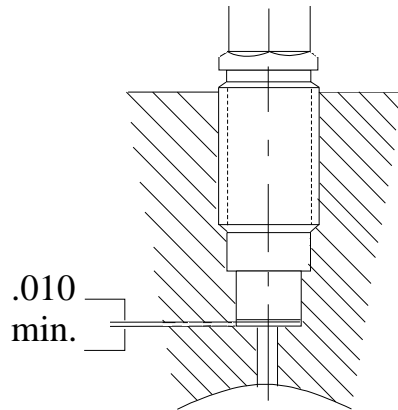

Figure 3

### 3.4 FLUSH MOUNT

When flush mounting, there is no reduced area passage from the sensor diaphragm to the test chamber; rather the sensor diaphragm is mounted flush with (or slightly recessed from) the inside surface of the test chamber.

**IMPORTANT:** Use this type of installation only if space or rise time considerations preclude the use of the recessed installation technique. In severe pyrotechnic environments, sensor life may be severely limited with flush installation.

### 3.5 FLASH TEMPERATURE EFFECTS

**SHOULDER SEAL:** The ceramic coating on the diaphragm of these sensors should render the flash thermal effect insignificant in most cases, especially when recess mounted.

**END SEAL:** If increased protection from flash thermal effects is required, the recess mount passage can be filled with silicone grease (DC-4 or equivalent).

The application of several layers of black vinyl electrical tape directly on the diaphragm has proven effective in many cases.

For flush mount installations, a silicone rubber coating approximately .010 in. (.0025 mm) thick can be effective. GE type 560 Silicone Rubber Kit is recommended. Follow manufacturer's instructions for application. It is best to recess the diaphragm .010 in. (.0025 mm) for this type of installation.

### 3.6 INSTALLING CABLES

Use only low noise treated coaxial cable (PCB Series 003 or equivalent), to connect the sensor to the charge amplifier, in-line voltage amplifier, or other high input impedance readout instrument. Protect the ultra high impedance connection against moisture contamination with shrink tubing or other suitable means. Figures 5 and 6 illustrate typical circuit connections.

It is good practice to support sensor cables by tying them to rigid structures, to prevent excessive motion which can generate noise and shorten cable life. Allow an adequate strain relief loop.

### 4.0 CALIBRATION

Series 118 sensors can be calibrated using quasi-static hydraulic techniques such as dead weight testers or by comparison with a standard dial gage.

Use the charge amplifier on "long time constant" and allow sensor to thermally stabilize before attempting to calibrate.

**NOTE:** Do not attempt to use a charge amplifier which has less than a 5000 second time constant in the "long TC" position.

Several charge amplifiers are specially designed for use with ceramic accelerometers measuring higher frequencies. In general, this type of charge amplifier is not suitable for calibration of quartz pressure sensors by quasi-static means.

Each sensor is supplied with a calibration certificate from the factory. Recalibration services are also provided at the factory for a nominal charge.

## 5.0 OPERATION

Most test set-ups will include Series 118 sensors coupled with electrostatic charge amplifiers, such as the PCB Series.

**NOTE:** Keep the charge amplifier input cable as short as practical. Electrical noise at the output of any charge amplifier is directly related to input cable length (capacitance).

Depress the ground button of the charge amplifier and adjust electrical zero if necessary. Range the amplifier as required, to give the necessary full-scale voltage.

For normal, drift-free operation, switch charge amplifier time constant selector to “medium” or “short” during use.

### 5.1 POLARITY

Since most charge amplifiers are inverting amplifiers, Series 118 sensors are designed to produce a negative-going charge as pressure increases at the diaphragm.

Special positive output versions are available for use with non-inverting ICP® source follower amplifiers. (Series 401 and 402).

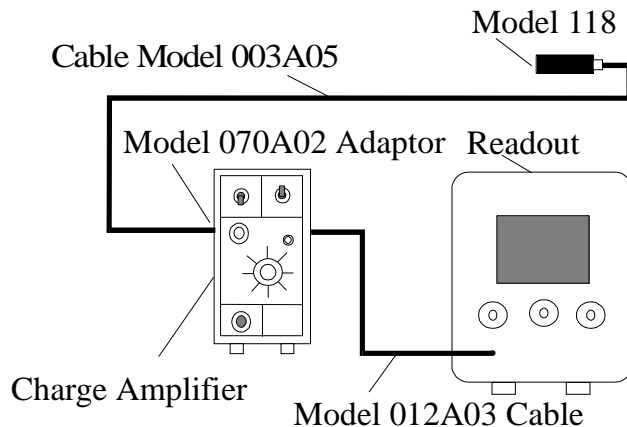

**Figure 4**

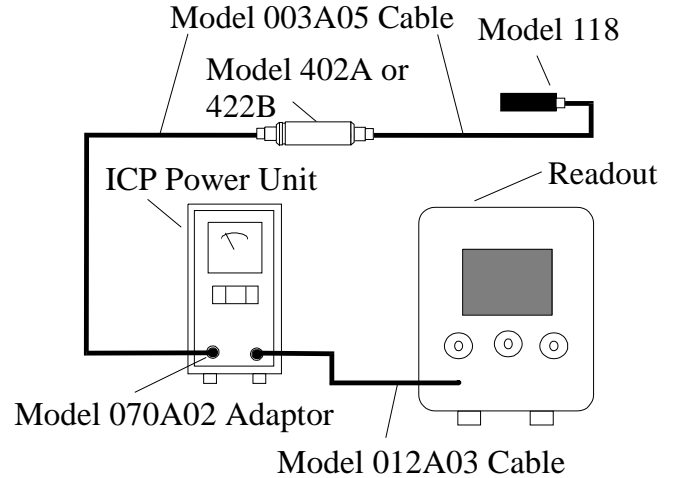

**Figure 5**

## 6.0 MAINTENANCE

The only maintenance required on Series 118 sensors is cleaning of the connector to restore insulation resistance.

During use in damp environments or after a period of storage, the insulation resistance of these sensors may degrade ( $10^{12}$  ohms is normal).

To restore insulation, wipe the connector end with a clean cloth or paper towel dipped in Trichlor® or an equivalent solvent. Bake the sensor in a 250 °F oven for several hours. A vacuum oven, if available, will hasten the process.

®ICP is a registered trademark of PCB Piezotronics

Model Number 118A02		<b>CHARGE OUTPUT PRESSURE SENSOR</b>		Revision: J ECN #: 34894	
<b>Performance</b>	<b>ENGLISH</b>	<b>SI</b>		<b>OPTIONAL VERSIONS</b>	
Sensitivity(± 15 %)	0.1 pC/psi	0.014 pC/kPa		Optional versions have identical specifications and accessories as listed for the standard model except where noted below. More than one option may be used.	
Measurement Range	20 kpsi	137,900 kPa		<b>M</b> - Metric Mount	
Maximum Pressure(static)	50 kpsi	344,750 kPa		<b>P</b> - Positive Output Polarity	
Resolution	200 mpsi	1.4 kPa		<b>W</b> - Water Resistant Cable	
Resonant Frequency	≥ 250 kHz	≥ 250 kHz			
Rise Time(Reflected)	≤ 2.0 μ sec	≤ 2.0 μ sec	[2]		
Non-Linearity	≤ 2.0 % FS	≤ 2.0 % FS			
<b>Environmental</b>				<b>NOTES:</b>	
Acceleration Sensitivity	≤ 0.05 psi/g	≤ 0.035 kPa/(m/s <sup>2</sup> )		[1] Nominal.	
Temperature Range(Operating)	-400 to +400 °F	-240 to +204 °C		[2] Zero-based, least-squares, straight line method.	
Temperature Coefficient of Sensitivity	≤ 0.1 %/°F	≤ 0.18 %/°C			
Maximum Flash Temperature	3000 °F	1649 °C			
Maximum Vibration	2000 g pk	19,620 m/s <sup>2</sup> pk			
Maximum Shock	20,000 g pk	196,200 m/s <sup>2</sup> pk			
<b>Electrical</b>				<b>SUPPLIED ACCESSORIES:</b>	
Output Polarity(Positive Pressure)	Negative	Negative		Model 065A06 Seal ring 0.318" OD x 0.250" ID x 0.010" thk 316L SS material (3)	
Capacitance	10 pF	10 pF	[1]		
Insulation Resistance(at room temp)	≥ 10 <sup>12</sup> ohm	≥ 10 <sup>12</sup> ohm			
<b>Physical</b>				Entered: <i>LT</i> Engineer: <i>APB</i> Sales: <i>KWW</i> Approved: <i>EB</i> Spec Number:	
Sensing Element	Quartz	Quartz		Date: <i>1-25-11</i> Date: <i>1-20-11</i> Date: <i>1-20-11</i> Date: <i>1-21-11</i> <b>118-1020-80</b>	
Sensing Geometry	Compression	Compression			
Housing Material	C-300	C-300			
Diaphragm	C-300	C-300			
Sealing	Welded Hermetic	Welded Hermetic			
Electrical Connector	10-32 Coaxial Jack	10-32 Coaxial Jack			
Weight	0.42 oz	12.0 gm			
<p><i>All specifications are at room temperature unless otherwise specified.</i>  <i>In the interest of constant product improvement, we reserve the right to change specifications without notice.</i></p> <p>ICP® is a registered trademark of PCB Group, Inc.</p>					
					Phone: 716-684-0001 Fax: 716-686-9129 E-Mail: <a href="mailto:pressure@pcb.com">pressure@pcb.com</a>
			3425 Walden Avenue, Depew, NY 14043		



118-1020-90

PCB Piezotronics Inc. claims proprietary rights in the information disclosed hereon. Neither it nor any reproduction thereof will be disclosed to others without the written consent of PCB Piezotronics Inc.

REVISIONS		
REV	DESCRIPTION	ECO
G	CONNECTOR REDRAWN	18545
H	UPDATED FORMATE	29412

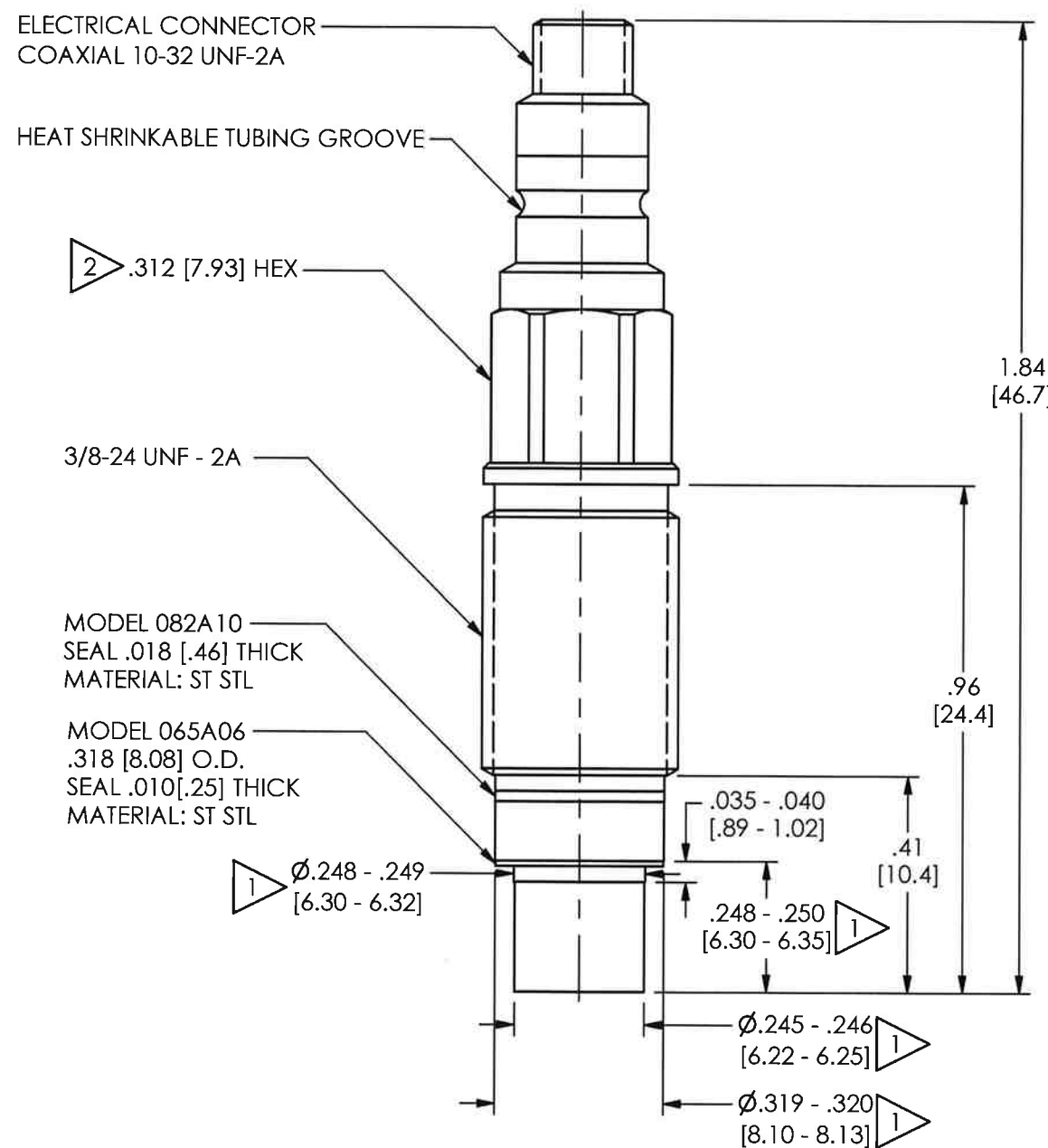

### FLUSH INSTALLATION

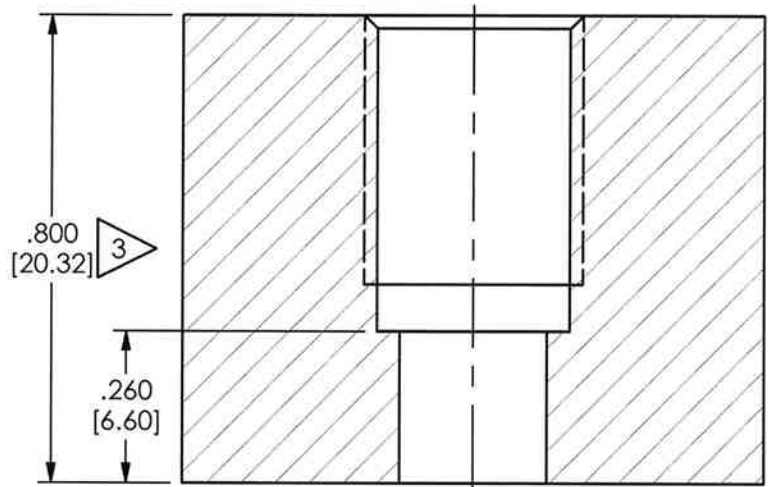

### RECESSED INSTALLATION

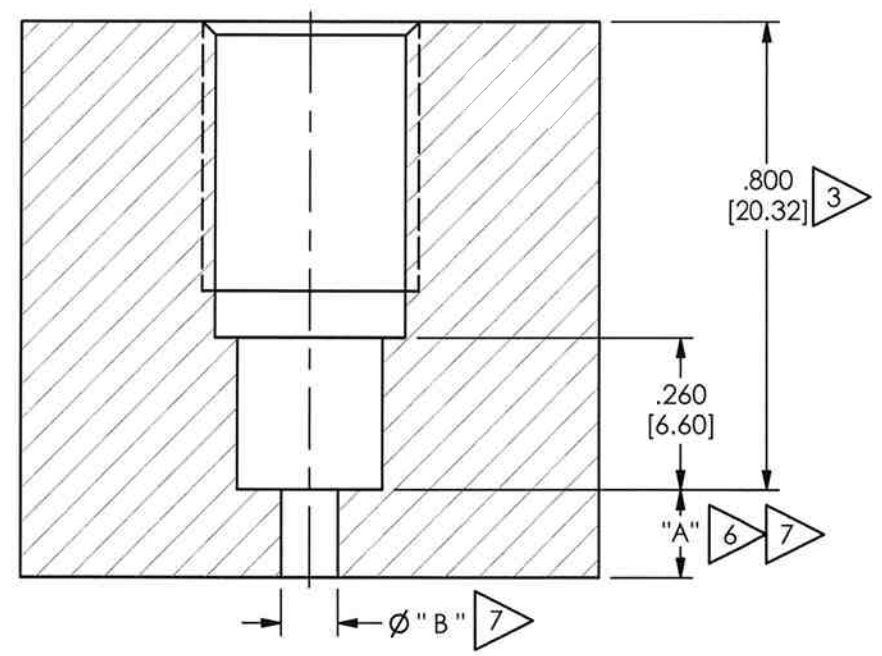

#### MOUNTING HOLE DIMENSIONS

- 3 5  $\square$   $\varnothing .252 \pm .001$  [6.40  $\pm$  .03] THRU
- 4 5  $\square$   $\varnothing .332 \pm .001$  [8.43  $\pm$  .03] (X .540 [13.72]  $\nabla$ )
- 8 3/8-24 UNF-2B X .460 [11.68]  $\nabla$  PERFECT THREAD

#### MOUNTING HOLE DIMENSIONS

- 3 5  $\square$   $\varnothing .252 \pm .001$  [6.40  $\pm$  .03] X .800 [20.32]  $\nabla$
- 4 5  $\square$   $\varnothing .332 \pm .001$  [8.43  $\pm$  .03] (X .540 [13.72]  $\nabla$ )
- 8 3/8-24 UNF-2B X .460 [11.68]  $\nabla$  PERFECT THREAD

- 8 CAUTION: DO NOT TOUCH SEAL SURFACE WITH TAP WHEN TAPPING HOLE.
- 7 DIMENSIONS "A" AND "B" TO SUIT USER REQUIREMENTS.
- 6 KEEP DIMENSION "A" AS SHORT AS POSSIBLE, SEE OPERATING GUIDE FOR OPTIMUM PASSAGE LENGTH.
- 5 THESE DIAMETERS TO BE CONCENTRIC TO WITHIN .001 [0.03] TIR.
- 4 SEAL SURFACE SHOULD BE FLAT AND FREE OF TOOL MARKS WITH A MINIMUM  $63 [1.6] \sqrt{\text{FINISH}}$  FOR BEST RESULTS.
- 3 DIMENSIONS SHOWN ARE FOR .800 [20.32] THICK WALL. COUNTERBORE FOR THICKER WALLS.
- 2 RECOMMENDED MOUNTING TORQUE ON .312 [7.93] HEX: 20-25 FT-LB [27-34 N-M]
- 1 MATERIAL: C-300 MARAGING STEEL.

UNLESS OTHERWISE SPECIFIED TOLERANCES ARE:		DRAWN	MCG	5/19/09	MFG	PRR	5/19/09	 3425 WALDEN AVE. DEPEW, NY 14043 (716) 684-0001 E-MAIL: sales@pcb.com
DIMENSIONS IN INCHES	DIMENSIONS IN MILLIMETERS [IN BRACKETS]	CHK'D	ECB	5/20/09	ENGR	APB	5/19/09	
DECIMALS XX $\pm .01$ XXX $\pm .005$	DECIMALS X $\pm .3$ XX $\pm 0.13$	APP'D	EB	5/19/09	SALES	RWM	5/19/09	
ANGLES $\pm 2$ DEGREES	ANGLES $\pm 2$ DEGREES	TITLE						
FILLETS AND RADII .003 - .005	FILLETS AND RADII [0.07 - 0.13]	INSTALLATION DRAWING MODEL 118A02 PRESSURE SENSOR						CODE IDENT. NO. 52681
		SCALE: 3X						DWG. NO. 118-1020-90
		SHEET 1 OF 1						