



Model 113B36
ICP® Pressure Sensor
Installation and Operating Manual

**For assistance with the operation of this product,
contact PCB Piezotronics, Inc.**

Toll-free: 800-828-8840
24-hour SensorLine: 716-684-0001
Fax: 716-684-0987
E-mail: info@pcb.com
Web: www.pcb.com



The information contained in this document supersedes all similar information that may be found elsewhere in this manual.

Total Customer Satisfaction – PCB Piezotronics guarantees Total Customer Satisfaction. If, at any time, for any reason, you are not completely satisfied with any PCB product, PCB will repair, replace, or exchange it at no charge. You may also choose to have your purchase price refunded in lieu of the repair, replacement, or exchange of the product.

Service – Due to the sophisticated nature of the sensors and associated instrumentation provided by PCB Piezotronics, user servicing or repair is not recommended and, if attempted, may void the factory warranty. Routine maintenance, such as the cleaning of electrical connectors, housings, and mounting surfaces with solutions and techniques that will not harm the physical material of construction, is acceptable. Caution should be observed to insure that liquids are not permitted to migrate into devices that are not hermetically sealed. Such devices should only be wiped with a dampened cloth and never submerged or have liquids poured upon them.

Repair – In the event that equipment becomes damaged or ceases to operate, arrangements should be made to return the equipment to PCB Piezotronics for repair. User servicing or repair is not recommended and, if attempted, may void the factory warranty.

Calibration – Routine calibration of sensors and associated instrumentation is

recommended as this helps build confidence in measurement accuracy and acquired data. Equipment calibration cycles are typically established by the users own quality regimen. When in doubt about a calibration cycle, a good “rule of thumb” is to recalibrate on an annual basis. It is also good practice to recalibrate after exposure to any severe temperature extreme, shock, load, or other environmental influence, or prior to any critical test.

PCB Piezotronics maintains an ISO-9001 certified metrology laboratory and offers calibration services, which are accredited by A2LA to ISO/IEC 17025, with full traceability to N.I.S.T. In addition to the normally supplied calibration, special testing is also available, such as: sensitivity at elevated or cryogenic temperatures, phase response, extended high or low frequency response, extended range, leak testing, hydrostatic pressure testing, and others. For information on standard recalibration services or special testing, contact your local PCB Piezotronics distributor, sales representative, or factory customer service representative.

Returning Equipment – *Following these procedures will insure that your returned materials are handled in the most expedient manner.* Before returning any equipment to PCB Piezotronics, contact your local distributor, sales representative, or factory customer service representative to obtain a Return

Materials Authorization (RMA) Number. This RMA number should be clearly marked on the outside of all package(s) and on the packing list(s) accompanying the shipment. A detailed account of the nature of the problem(s) being experienced with the equipment should also be included inside the package(s) containing any returned materials.

A Purchase Order, included with the returned materials, will expedite the turn-around of serviced equipment. It is recommended to include authorization on the Purchase Order for PCB to proceed with any repairs, as long as they do not exceed 50% of the replacement cost of the returned item(s). PCB will provide a price quotation or replacement recommendation for any item whose repair costs would exceed 50% of replacement cost, or any item that is not economically feasible to repair. For routine calibration services, the Purchase Order should include authorization to proceed and return at current pricing, which can be obtained from a factory customer service representative.

Warranty – All equipment and repair services provided by PCB Piezotronics, Inc. are covered by a limited warranty against defective material and workmanship for a period of one year from date of original purchase. Contact

PCB for a complete statement of our warranty. Expendable items, such as batteries and mounting hardware, are not covered by warranty. Mechanical damage to equipment due to improper use is not covered by warranty. Electronic circuitry failure caused by the introduction of unregulated or improper excitation power or electrostatic discharge is not covered by warranty.

Contact Information – International customers should direct all inquiries to their local distributor or sales office. A complete list of distributors and offices can be found at www.pcb.com. Customers within the United States may contact their local sales representative or a factory customer service representative. A complete list of sales representatives can be found at www.pcb.com. Toll-free telephone numbers for a factory customer service representative, in the division responsible for this product, can be found on the title page at the front of this manual. Our ship to address and general contact numbers are:

PCB Piezotronics, Inc.
3425 Walden Ave.
Depew, NY 14043 USA
Toll-free: (800) 828-8840
24-hour SensorLineSM: (716) 684-0001
Website: www.pcb.com
E-mail: info@pcb.com

**OPERATION MANUAL FOR
QUARTZ PRESSURE SENSORS**
SERIES 102A, A03, A04, A06, A12, A15, A21, A22
SERIES 113A21, A22, A23, A24, A26, A27, A28
SERIES 113A31, A32, A33, A34, A36, A37, A38
SERIES 113B51, B52, B53
SERIES 113B31, B32, B33, B34, B36, B37, B38

1.0 INTRODUCTION

This series of miniature dynamic pressure sensors is specifically designed for shock tube and blast wave measurements and for other applications requiring very high frequency, near non-resonant response.

The term used to describe the transient response of this model series is "Frequency Tailoring" and it encompasses several mechanical and electrical design features coupled with stringent in-process fabrication/test procedures with heavy emphasis on the shock tube as a tool.

2.0 DESCRIPTION

Although this series consists of sensors with three basic mechanical configurations and six different sensitivities, each model is basically similar in internal design.

The figure above shows the components of the basic ICP[®] probe, i.e. the piezoelectric element and the ICP[®] source follower amplifier. These components are joined together as an inseparable sealed assembly at the factory. Disassembly should not be attempted in the field.

Series 113B20 are in a probe configuration and are installed with a hollow clamp nut with 5/16-24 external threads. The housing of these models is at electrical ground potential.

Series 113B30 are similar to the **B20 Series** with an additional feature; all Invar construction. The all Invar sensors are designed to have minimal susceptibility to thermal transient events and are specifically suited for high-temperature shock and blast measurements.

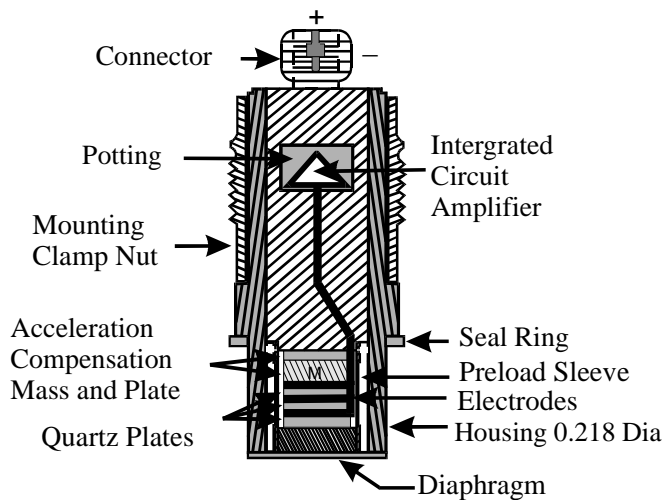

Typical ICP[®] Probe Style Sensor

Each utilizes the acceleration-compensated **Series 113** quartz piezoelectric element coupled to a source follower type miniature electronics. (See "General Guide to ICP[®] Instrumentation," G-0001B, for a detailed description of the ICP[®] concept.)

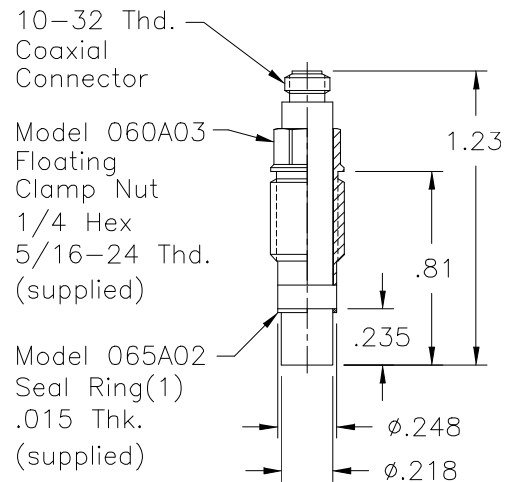

Series 113: Probe Style Sensor

Series 102 consist of the basic 113A20 Series probe, as in the above mentioned series, mounted in a 3/8-24 threaded mounting adaptor. The probe is installed at the factory in an "off ground" configuration, i.e. the probe body is insulated from the external mounting adaptor body.

The Model 102A12 utilizes the same inner probe design as the above two designs but in a 3/8-24

**OPERATION MANUAL FOR
QUARTZ PRESSURE SENSORS**
SERIES 102A, A03, A04, A06, A12, A15, A21, A22
SERIES 113A21, A22, A23, A24, A26, A27, A28
SERIES 113A31, A32, A33, A34, A36, A37, A38
SERIES 113B51, B52, B53
SERIES 113B31, B32, B33, B34, B36, B37, B38

threaded adaptor with floating clamp nut to allow adjustment of diaphragm mounting depth where it is necessary to adapt to various wall thicknesses. These models are supplied only as low-pressure (250 psi and 100 psi) sensors and are also "off ground".

Models 102A21 and 102A22 are high-temperature ICP[®] versions to 400 °F (204 °C), with a 3/8-24 straight threads adaptor and 1/8-27 NPT adaptor, respectively.

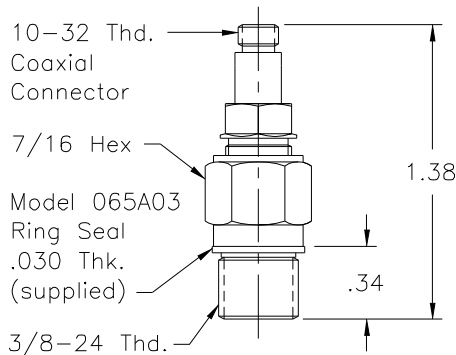

Series 102: Thread Mount Design, Ground-Isolated Sensor

3.0 INSTALLATION

This manual contains outline and installation information for your specific model.

Prepare mounting ports in accordance with instructions given in specific installation drawings, paying particular attention to sealing surfaces. These surfaces must be smooth and free from chatter marks, nicks and other irregularities which could preclude a pressure tight seal.

To fully realize the high-frequency response capabilities of this sensor series, flush mounting of the diaphragm must be used.

In some cases, where flash temperatures such as those generated by blasts and shock fronts are present, it may be necessary to thermally insulate the diaphragm to minimize signals generated by these effects.

Drawing Number: 21075
 Revision: B
 ECN Number: 41425

Common black vinyl electrical tape has been found to be an effective insulating material in many cases. One or more layers may be used across the end of diaphragm and adaptor.

A silicone rubber coating approximately .010" thick has also been proven effective in many applications. General Electric RTV type 106 is recommended. Apply the rubber coating to the surface of the diaphragm and allow it to cure in accordance with the manufacturer's instructions. (If you have ordered the **CA option**, ablative coated models, further protection will not be necessary.)

Although ICP[®] sensors have low-output impedance and in general are not affected by moisture, in extreme environments it is good practice to protect cable connections with shrink tubing.

It is not necessary to use low-noise cable with this sensor series. In fact, an optional Model 070**B09** Solder Connector Adaptor allows the use of ordinary two-wire cable if desired.

4.0 OPERATION

It is only necessary to supply the sensor with a 2 to 20 mA constant current at +20 to +30 VDC through a current-regulating diode or equivalent circuit. (See guide G-0001B for powering and signal utilization information pertaining to all ICP[®] instrumentation).

Most of the signal conditioners manufactured by PCB have an adjustable current feature allowing a choice of input currents from 2 to 20 mA. In general, for lowest noise (best resolution), choose the lower current ranges. For driving long cables (to several thousand feet), use higher current, up to 20 mA maximum.

To operate system using a PCB signal conditioner:

1. Switch power on.
2. Wait several minutes for the IC amplifier to turn on and stabilize.
3. Proceed with measurements.

**OPERATION MANUAL FOR
QUARTZ PRESSURE SENSORS**
SERIES 102A, A03, A04, A06, A12, A15, A21, A22
SERIES 113A21, A22, A23, A24, A26, A27, A28
SERIES 113A31, A32, A33, A34, A36, A37, A38
SERIES 113B51, B52, B53
SERIES 113B31, B32, B33, B34, B36, B37, B38

5.0 POLARITY

The sensors in this series produce a positive-going output voltage for increasing pressure input.

6.0 LOW-FREQUENCY RESPONSE

The low-frequency response of an ICP[®] system is determined by:

1. The discharge T.C. of the sensor
2. If AC-coupled at power unit, the coupling time constant.

Consult Section 7.0 in guide G-0001B detailed explanation of low-frequency characteristics of ICP[®] instruments.

7.0 HIGH-FREQUENCY RESPONSE

Frequency tailoring and the very high-natural frequency of the sensor give an extremely wide usable frequency range (beyond 100 kHz). Exceptionally fast response time (1 μsec) and clean, virtually non-resonant response to rapid step functions are also features of these sensors. As mentioned previously, the diaphragm must be flush-mounted to fully realize the high-frequency response capabilities of this series.

8.0 CALIBRATION

Piezoelectric sensors are dynamic devices, but static calibration means can be employed if discharge time constants are sufficiently long. Generally, static methods are not employed below several hundred seconds time constant.

To employ static means, direct couple the sensor to the DVM readout using a T-Connector from the sensor jack or use the Model 484B in the calibrate mode. Apply pressure with dead weight tester and take readings quickly. Release pressure after each calibration point.

For the shorter time constant, rapid step functions of pressure are generated by a pneumatic pressure pulse

calibrator or dead weight tester and readout is by recorder or storage oscilloscope.

PCB offers a complete calibration service. Consult factory for details.

®ICP is a registered trademark of PCB Piezotronics

PCB Piezotronics Inc. claims proprietary rights in the information disclosed hereon. Neither it nor any reproduction thereof will be disclosed to others without the written consent of PCB Piezotronics Inc.

REVISIONS

REV	DESCRIPTION	ECN	APP'D
NR	RELEASED TO DRAFTING		MDF 8/6/08

40623

ELECTRICAL CONNECTOR
10-32 UNF-2A

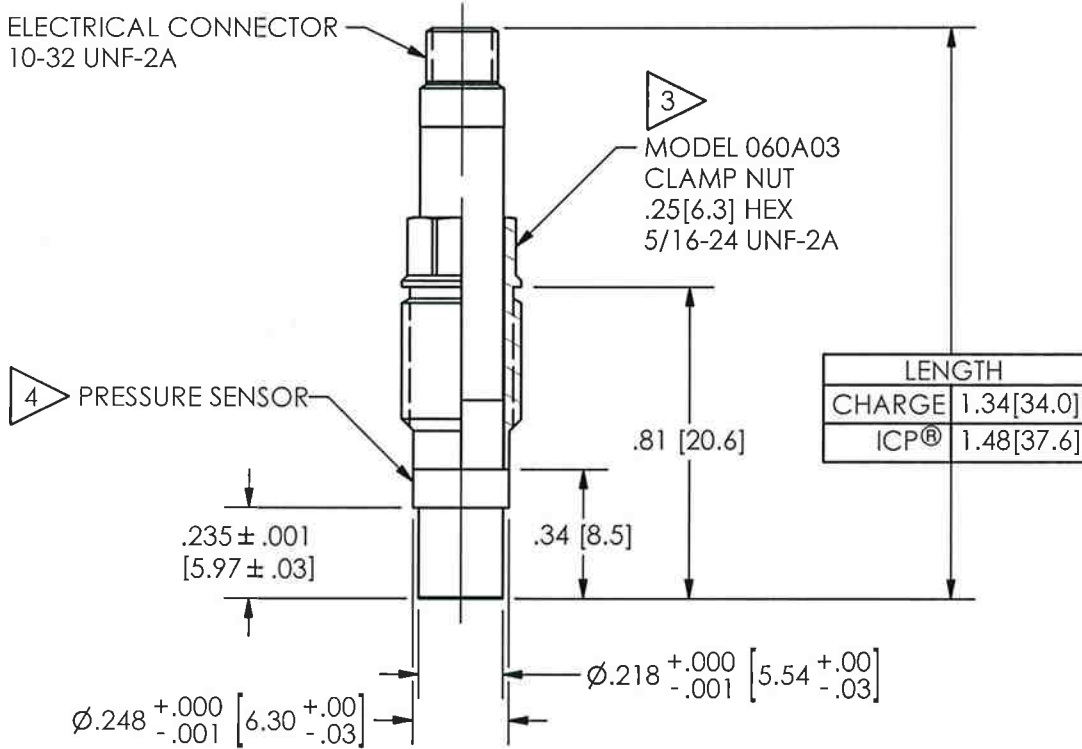

MOUNTING HOLE PREPARATION

1 FLUSH INSTALLATION

∅.221 ± .002 [5.61 ± .05]
THRU
└┐ ∅.250 ^{+0.003} _{-.000} [6.35 ^{+0.08} _{-.00}]
X .520 [13.20] ▽
└┐ ∅.277 [7.04]
X .480 [12.19] ▽
5/16-24 UNF-2B
X .400 [10.16] ▽

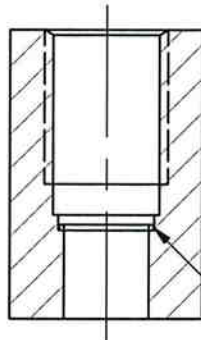

RECESSED INSTALLATION

└┐ ∅.250 ^{+0.003} _{-.000} [6.35 ^{+0.08} _{-.00}]
X .750 [19.05] ▽
└┐ ∅.277 [7.04]
X .480 [12.19] ▽
5/16-24 UNF-2B
X .400 [10.16] ▽

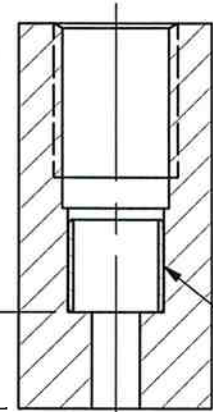

MODEL 065A02
SEAL
.015 [.38] THK

MODEL 065A05
SEAL
.240 [6.10] LONG

2 "A"

∅ "B" 2

4 IC AMP AND SENSOR ARE SEALED ASSEMBLIES AND SHOULD BE RETURNED TO THE FACTORY FOR SERVICE AND/OR REPAIR.

3 RECOMMENDED TORQUE ON .25[6.3] HEX: 25-35 IN. LBS. [2.8-3.9 Nm]

2 DIMENSIONS "A" AND "B" TO SUIT USER REQUIREMENTS.

1 THESE DIMENSIONS FOR .750[19.05] THICK WALL. COUNTERBORE FOR THICKER WALLS.

UNLESS OTHERWISE SPECIFIED TOLERANCES ARE:

DIMENSIONS IN INCHES

DIMENSIONS IN MILLIMETERS
[IN BRACKETS]

DECIMALS XX ± .01
XXX ± .005
ANGLES ± 2 DEGREES

DECIMALS X ± 0.3
XX ± 0.13
ANGLES ± 2 DEGREES

FILLETS AND RADII
.003 - .005

FILLETS AND RADII
[0.07 - 0.13]

DRAWN	MDF 8/6/08	MFG	P.R.R. 8-7-08
CHK'D	MDF 8/6/08	ENGR	RF 8/8/08
APP'D	8/7/08	SALES	KWW 8/7/08

TITLE
INSTALLATION DRAWING
ENGLISH MOUNT
MODELS 113B SERIES
PRESSURE SENSOR

PCB PIEZOTRONICS™

3425 WALDEN AVE. DEPEW, NY 14043
(716) 684-0001 E-MAIL: sales@pcb.com

CODE IDENT. NO. 52681	DWG. NO. 40623
--------------------------	-------------------

SCALE: 2 X SHEET 1 OF 2

PCB Piezotronics Inc. claims proprietary rights in the information disclosed herein. Neither it nor any reproduction thereof will be disclosed to others without the written consent of PCB Piezotronics Inc.

REVISIONS

REV	DESCRIPTION	ECN	APP'D
	- SEE SHEET ONE -		<i>mDF 8/6/08</i>

40623

ELECTRICAL CONNECTOR
10-32 UNF-2A

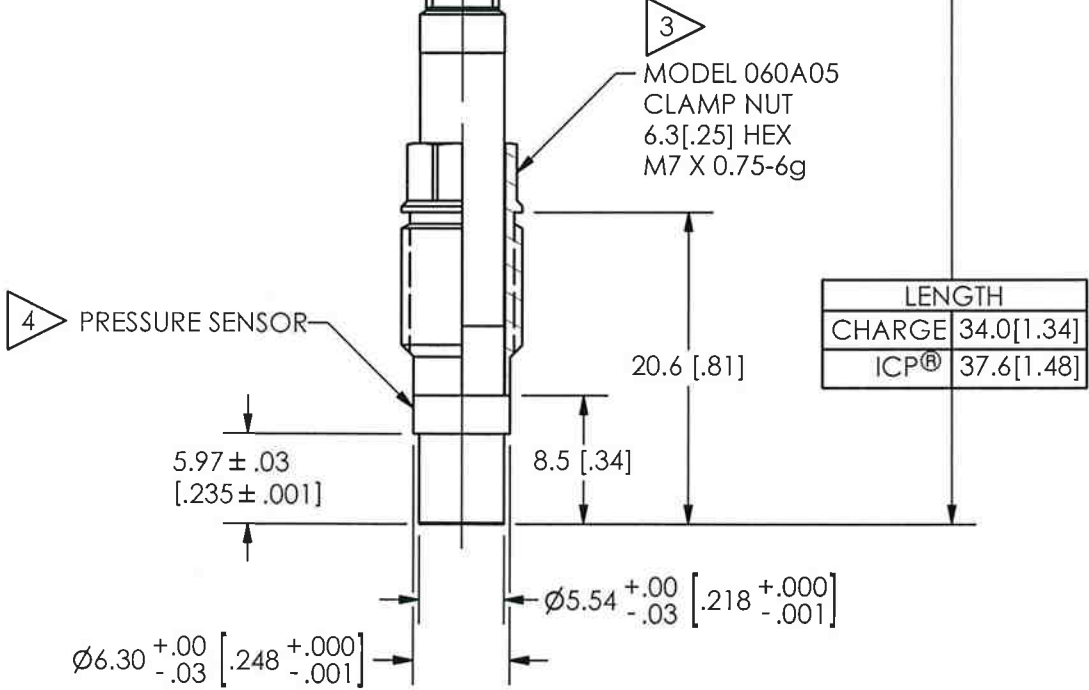

MOUNTING HOLE PREPARATION

1 FLUSH INSTALLATION

Ø5.61 ± .05 [.221 ± .002]
THRU
└─┬─┐ Ø6.35 ^{+0.08} _{-.00} [.250 ^{+0.003} _{-.000}]
X 13.20 [.520] ▽
M7 X 0.75-6H
X 10.16 [.400] ▽

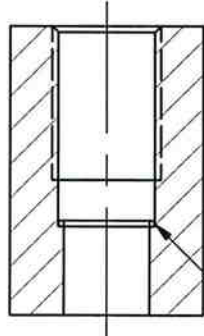

RECESSED INSTALLATION

└─┬─┐ Ø6.35 ^{+0.08} _{-.00} [.250 ^{+0.003} _{-.000}]
X 19.05 [.750] ▽
M7 X 0.75-6H
X 10.16 [.400] ▽

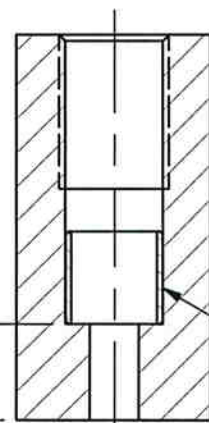

MODEL 065A02 SEAL
.38[.015] THK

MODEL 065A05 SEAL
.610[.240] LONG

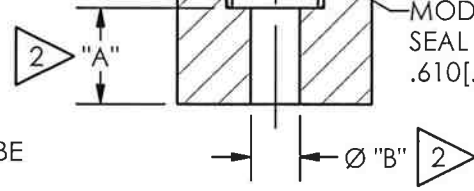

- 4 IC AMP AND SENSOR ARE SEALED ASSEMBLIES AND SHOULD BE RETURNED TO THE FACTORY FOR SERVICE AND/OR REPAIR.
- 3 RECOMMENDED TORQUE ON 6.3[.25] HEX: 2.8-3.9 Nm[25-35 IN. LBS.].
- 2 DIMENSIONS "A" AND "B" TO SUIT USER REQUIREMENTS.
- 1 THESE DIMENSIONS FOR 19.05[.750] THICK WALL. COUNTERBORE FOR THICKER WALLS.

UNLESS OTHERWISE SPECIFIED TOLERANCES ARE:

DIMENSIONS IN INCHES
[IN BRACKETS]

DECIMALS XX ± .01
XXX ± .005
ANGLES ± 2 DEGREES

DIMENSIONS IN MILLIMETERS

DECIMALS X ± 0.3
XX ± 0.13
ANGLES ± 2 DEGREES

FILLETS AND RADII
.003 - .005

FILLETS AND RADII
[0.07 - 0.13]

DRAWN	<i>mDF 8/6/08</i>	MFG	<i>P.R.R. 8-7-08</i>
CHK'D	<i>mDF 8/6/08</i>	ENGR	<i>RF 8/6/08</i>
APP'D	<i>reliable flow</i>	SALES	<i>KIM 8/6/08</i>
TITLE	INSTALLATION DRAWING METRIC MOUNT MODELS 113B SERIES PRESSURE SENSOR		

PCB PIEZOTRONICS™

3425 WALDEN AVE. DEPEW, NY 14043
(716) 684-0001 E-MAIL: sales@pcb.com

CODE IDENT. NO. 52681	DWG. NO. 40623
--------------------------	--------------------------

SCALE: 2 X SHEET 2 OF 2