



Model 112A22

High resolution ICP® pressure probe, 50 psi, 100 mV/psi, 0.218" dia.

Installation and Operating Manual

**For assistance with the operation of this product,
contact PCB Piezotronics, Inc.**

**Toll-free: 800-828-8840
24-hour SensorLine: 716-684-0001
Fax: 716-684-0987
E-mail: info@pcb.com
Web: www.pcb.com**



The information contained in this document supersedes all similar information that may be found elsewhere in this manual.

Total Customer Satisfaction – PCB Piezotronics guarantees Total Customer Satisfaction. If, at any time, for any reason, you are not completely satisfied with any PCB product, PCB will repair, replace, or exchange it at no charge. You may also choose to have your purchase price refunded in lieu of the repair, replacement, or exchange of the product.

Service – Due to the sophisticated nature of the sensors and associated instrumentation provided by PCB Piezotronics, user servicing or repair is not recommended and, if attempted, may void the factory warranty. Routine maintenance, such as the cleaning of electrical connectors, housings, and mounting surfaces with solutions and techniques that will not harm the physical material of construction, is acceptable. Caution should be observed to insure that liquids are not permitted to migrate into devices that are not hermetically sealed. Such devices should only be wiped with a dampened cloth and never submerged or have liquids poured upon them.

Repair – In the event that equipment becomes damaged or ceases to operate, arrangements should be made to return the equipment to PCB Piezotronics for repair. User servicing or repair is not recommended and, if attempted, may void the factory warranty.

Calibration – Routine calibration of sensors and associated instrumentation is

recommended as this helps build confidence in measurement accuracy and acquired data. Equipment calibration cycles are typically established by the users own quality regimen. When in doubt about a calibration cycle, a good “rule of thumb” is to recalibrate on an annual basis. It is also good practice to recalibrate after exposure to any severe temperature extreme, shock, load, or other environmental influence, or prior to any critical test.

PCB Piezotronics maintains an ISO-9001 certified metrology laboratory and offers calibration services, which are accredited by A2LA to ISO/IEC 17025, with full traceability to N.I.S.T. In addition to the normally supplied calibration, special testing is also available, such as: sensitivity at elevated or cryogenic temperatures, phase response, extended high or low frequency response, extended range, leak testing, hydrostatic pressure testing, and others. For information on standard recalibration services or special testing, contact your local PCB Piezotronics distributor, sales representative, or factory customer service representative.

Returning Equipment – *Following these procedures will insure that your returned materials are handled in the most expedient manner.* Before returning any equipment to PCB Piezotronics, contact your local distributor, sales representative, or factory customer service representative to obtain a Return

Materials Authorization (RMA) Number. This RMA number should be clearly marked on the outside of all package(s) and on the packing list(s) accompanying the shipment. A detailed account of the nature of the problem(s) being experienced with the equipment should also be included inside the package(s) containing any returned materials.

A Purchase Order, included with the returned materials, will expedite the turn-around of serviced equipment. It is recommended to include authorization on the Purchase Order for PCB to proceed with any repairs, as long as they do not exceed 50% of the replacement cost of the returned item(s). PCB will provide a price quotation or replacement recommendation for any item whose repair costs would exceed 50% of replacement cost, or any item that is not economically feasible to repair. For routine calibration services, the Purchase Order should include authorization to proceed and return at current pricing, which can be obtained from a factory customer service representative.

Warranty – All equipment and repair services provided by PCB Piezotronics, Inc. are covered by a limited warranty against defective material and workmanship for a period of one year from date of original purchase. Contact

PCB for a complete statement of our warranty. Expendable items, such as batteries and mounting hardware, are not covered by warranty. Mechanical damage to equipment due to improper use is not covered by warranty. Electronic circuitry failure caused by the introduction of unregulated or improper excitation power or electrostatic discharge is not covered by warranty.

Contact Information – International customers should direct all inquiries to their local distributor or sales office. A complete list of distributors and offices can be found at www.pcb.com. Customers within the United States may contact their local sales representative or a factory customer service representative. A complete list of sales representatives can be found at www.pcb.com. Toll-free telephone numbers for a factory customer service representative, in the division responsible for this product, can be found on the title page at the front of this manual. Our ship to address and general contact numbers are:

PCB Piezotronics, Inc.
3425 Walden Ave.
Depew, NY 14043 USA
Toll-free: (800) 828-8840
24-hour SensorLineSM: (716) 684-0001
Website: www.pcb.com
E-mail: info@pcb.com

**OPERATION MANUAL FOR
ICP® PRESSURE SENSORS
Models 102A02, A05, A07, A09
Models 112A21, A22, A23**

1.0 INTRODUCTION

The series of miniature pressure sensors described by this operating guide is designed for low pressure, high resolution applications and features acceleration compensation.

Uses include monitoring of low pressure hydraulic and pneumatic phenomena in the presence of shock and vibration such as on jet engines, compressors, turbines and other operating machinery, high intensity sound and turbulence measurements, and many other industrial R & D applications.

2.0 DESCRIPTION

This series is comprised of six sensor models having high sensitivities, but differing in mechanical configuration.

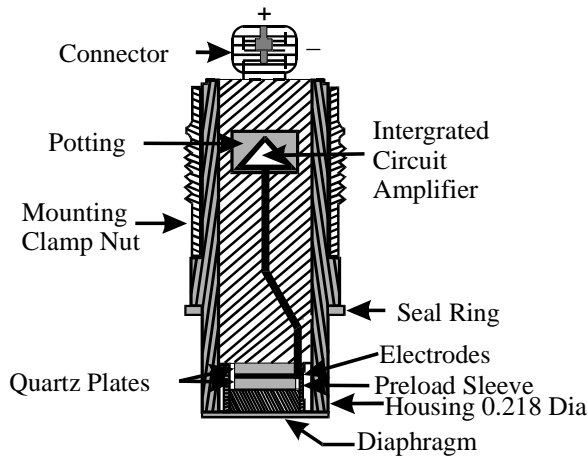

Typical ICP® Probe Style Sensor

Each model utilizes the basic ICP® pressure probe as shown in above figure. The pressure probe consists of the Model 112A high sensitivity acceleration-compensated quartz element and an IC source follower amplifier joined together as an inseparable assembly.

Refer to "General Guide to ICP® Instrumentation" G-0001B for a complete treatment of the ICP® concept.

Models 112A21, 112A22 and 112A23 are in the basic probe configuration as shown in Figure 1, and are installed with a hollow clamp nut with 5/16-24 external threads. The housings of these models are at electrical ground potential.

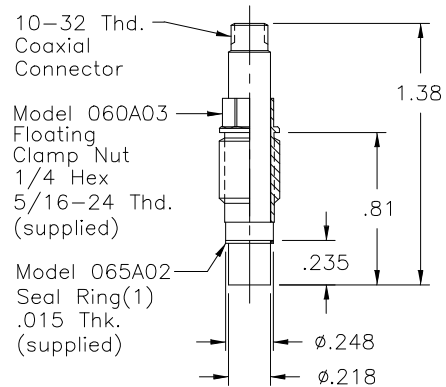

Series 111: Probe Style Sensor

The Model 102A05 utilizes the same basic pressure probe, mounted in a 3/8-24 threaded mounting adaptor with shoulder seal. The probe is assembled into the adaptor at the factory in an "off ground" configuration, i.e., the probe body is electrically insulated from the external mounting adaptor body. Do not attempt to disassemble probe and adaptor.

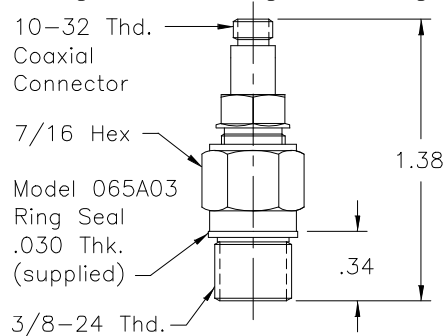

Model 102A05 Thread Mount Design, Ground-Isolated Sensor

**OPERATION MANUAL FOR
ICP® PRESSURE SENSORS
Models 102A02, A05, A07, A09
Models 112A21, A22, A23**

Models 102A02, 102A07, and 102A09 utilize the same inner probe design but in a 3/8-24 threaded adaptor with floating clamp nut to allow adjustment of diaphragm depth where it is necessary to adapt to various wall thicknesses. These models are supplied only in low pressure (100 and 50 psi) versions and are also "off ground".

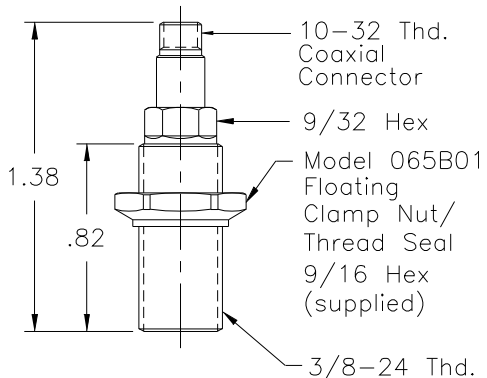

102A's: Thread Mount with Floating Clamp Nut, Ground-Isolated Sensor

3.0 INSTALLATION

This manual contains outline and installation information for your specific model in this series. Prepare mounting ports in accordance with the installation drawing for the specific model, paying particular attention to sealing surfaces. These surfaces must be smooth and free from chatter marks, nicks and other irregularities which could preclude a pressure-tight seal.

Seals are provided with each sensor and should always be used. Extra seals for all standard models are in stock at the factory. Replace seals when they become unserviceable.

In some cases, e.g., where flash temperatures such as those generated by combustion processes are present, it may be necessary to thermally insulate the diaphragm to minimize spurious signals generated by these effects.

Common black vinyl electrical tape has been found to be an effective insulating material in many cases. One or more layers may be used across the end of the diaphragm without affecting response or sensitivity.

A silicone rubber coating approximately .010" thick has also been proven effective in many applications. General Electric RTV type 106 silicone rubber is recommended. Apply the rubber coating and allow to cure in accordance with the manufacturer's instructions.

Although ICP® sensors have low output impedance and in general are not affected by moisture, in extreme environments it is good practice to protect cable connections with shrink tubing.

It is not necessary to use low-noise coaxial cable with this sensor series. In fact, a Model 070A09 solder connector adaptor that allows the use of ordinary two-wire cable is desired.

4.0 OPERATION

It is only necessary to supply the sensor with a 2 to 20 mA constant current at +20 to +30 VDC through a current-regulating diode or equivalent circuit. (See Guide G-0001B for powering and signal utilization information pertaining to all ICP® instrumentation).

Most of the signal conditioners manufactured by PCB have an adjustable current feature allowing a choice of input currents from 2 to 20 mA. In general, for lowest noise (best resolution) choose the low current ranges and for driving long cables (to several thousand feet) use the higher current, up to 20 mA maximum.

To operate system using a PCB signal conditioner:

1. Switch power on.
2. Wait several minutes for the IC amplifier to turn on and stabilize.
3. Proceed with measurements.

4.1 OPERATING CONSIDERATION FOR MODEL 112A23

The Model 112A23 features a low-noise amplifier which, based on a peak-to-peak broadband noise factor of 50 μ V, results in a resolution of .001 psi.

**OPERATION MANUAL FOR
ICP® PRESSURE SENSORS
Models 102A02, A05, A07, A09
Models 112A21, A22, A23**

Defined for practical purposes as the minimum readout signal, the resolution is based on the sensitivity of 50 mV/psi and a low noise amplifier of 50 μ V peak noise.

Thus, $50 \mu\text{V}/50\text{mV} = .001$ psi resolution

The output bias voltage of the Model 112A23 is 5.0 volts, half the bias voltage of most PCB pressure sensors. This will cause the bias monitor meter on PCB power supplies to read at the low end of the green band.

5.0 POLARITY

This sensor series produces a positive-going output voltage for increasing pressure input.

6.0 LOW FREQUENCY RESPONSE

The low frequency response of an ICP® system is determined by:

1. The discharge time constant of the sensor, and,
2. If AC-coupled at power unit, the coupling time constant.

Consult Section 7.0 in Guide G-0001B for detailed explanation of low frequency characteristics of ICP® instruments.

7.0 CALIBRATION

Piezoelectric sensors are dynamic devices, but static calibration methods may be employed if discharge time constants are sufficiently long. Generally, static methods are not employed below several hundred seconds discharge time constant.

To employ static methods, directly couple the sensor to the DVM readout using a T-connector from the XD4R jack or use the Model 484B in the "calibrate" mode. Apply pressure with dead weight tester and take readings quickly. Release pressure after each calibration point.

For the shorter discharge time constant series, a rapid pressure step must be generated by a pneumatic pressure pulse calibrator or dead weight tester and readout is by recorder or storage oscilloscope.



PCB offers a complete recalibration service. Consult factory for details.

**OPERATION MANUAL FOR
ICP® PRESSURE SENSORS
Models 102A02, A05, A07, A09
Models 112A21, A22, A23**

8.0 MAINTENANCE

The miniature size sealed construction precludes field maintenance. Should service be required, return unit to factory with note describing problem.

®ICP is a registered trademark of PCB Piezotronics

Model Number 112A22	ICP® PRESSURE SENSOR		Revision: H ECN #: 40791	
Performance	ENGLISH	SI	OPTIONAL VERSIONS	
Measurement Range(for ±5V output)	50 psi	345 kPa	Optional versions have identical specifications and accessories as listed for the standard model except where noted below. More than one option may be used. E - Emralon coating [4] Coating Emralon Emralon Electrical Isolation 10 ⁸ Ohm 10 ⁸ Ohm Supplied Accessory : Model 065A08 Isolation ring 0.250"OD x 0.218" ID x 0.027" thk anodized aluminum (3) Supplied Accessory : Model 065A22 Isolation Seal, .250" OD x .218" ID x .015", Torlon or Vespel (3) H - Hermetic Seal [4] Sealing Welded Hermetic Welded Hermetic J - Ground Isolated [4][5] N - Negative Output Polarity [4] S - Stainless Steel Diaphragm [4] Diaphragm 316L Stainless Steel 316L Stainless Steel W - Water Resistant Cable [6][4] Supplied Accessory : Model 060A03 Clamp nut, 5/16-24-2A thd, 1/4" hex, stainless steel (1) WM - Water Resistant Cable [6][4] Supplied Accessory : Model 060A05 Clamp nut M7 x 0.75-6g thd (1)	
Useful Overrange(for ± 10V output)	100 psi	690 kPa		
Sensitivity(± 15 %)	100 mV/psi	14.5 mV/kPa		
Maximum Pressure	500 psi	3450 kPa		
Resolution	1 mpsi	0.007 kPa		
Resonant Frequency	≥ 250 kHz	≥ 250 kHz		
Rise Time	≤ 2.0 μ sec	≤ 2.0 μ sec		
Low Frequency Response(-5 %)	0.50 Hz	0.50 Hz		
Non-Linearity	≤ 1.0 % FS	≤ 1.0 % FS		
Environmental				
Acceleration Sensitivity	≤ 0.002 psi/g	≤ 0.0014 kPa/(m/s ²)		
Temperature Range(Operating)	-100 to +275 °F	-73 to +135 °C		
Temperature Coefficient of Sensitivity	≤ 0.06 %/°F	≤ 0.108 %/°C		
Maximum Flash Temperature	3000 °F	1650 °C		
Maximum Shock	20,000 g pk	196,000 m/s ² pk		
Electrical				
Output Polarity(Positive Pressure)	Positive	Positive		
Discharge Time Constant(at room temp)	≥ 1.0 sec	≥ 1.0 sec		
Excitation Voltage	22 to 30 VDC	22 to 30 VDC		
Constant Current Excitation	2 to 20 mA	2 to 20 mA		
Output Impedance	<100 Ohm	<100 Ohm		
Output Bias Voltage	8 to 14 VDC	8 to 14 VDC		
Physical				
Sensing Geometry	Compression	Compression		
Sensing Element	Quartz	Quartz		
Housing Material	17-4 Stainless Steel	17-4 Stainless Steel		
Diaphragm	Invar	Invar		
Sealing	Welded Hermetic	Welded Hermetic		
Electrical Connector	10-32 Coaxial Jack	10-32 Coaxial Jack		
Weight(with clamp nut)	0.21 oz	6.0 gm		
	NOTES: [1] For +10 volt output, minimum 24 VDC supply voltage required. Negative 10 volt output may be limited by output bias. [2] Zero-based, least-squares, straight line method. [3] See PCB Declaration of Conformance PS023 for details. [4] For sensor mounted in thread adaptor, see adaptor installation drawing for supplied accessories. [5] Used with optional mounting adaptor. [6] Clamp nut installed prior to cable attachment			
	SUPPLIED ACCESSORIES: Model 060A03 Clamp nut, 5/16-24-2A thd, 1/4" hex, stainless steel (1) Model 060A05 Clamp nut M7 x 0.75-6g thd (1) Model 065A02 Seal ring, sensor flush mount, 0.248" OD x 0.219" ID x 0.015" thk, brass (3) Model 065A05 Seal sleeve sensor recess mount 0.248" OD x 0.221" ID x 0.240" thk 17-4 (1)			
	Entered: AP	Engineer: MJK	Sales: KWW	Approved: BAM
Date: 3/19/2013	Date: 3/19/2013	Date: 3/19/2013	Date: 3/19/2013	6476
			Phone: 716-684-0001 Fax: 716-684-0987 E-Mail: info@pcb.com	
3425 Walden Avenue, Depew, NY 14043				

All specifications are at room temperature unless otherwise specified.
 In the interest of constant product improvement, we reserve the right to change specifications without notice.

ICP® is a registered trademark of PCB Group, Inc.

PCB Piezotronics Inc. claims proprietary rights in the information disclosed hereon. Neither it nor any reproduction thereof will be disclosed to others without the written consent of PCB Piezotronics Inc.

REVISIONS

REV	DESCRIPTION	ECN	APP'D
D	CORRECT SIMENSION	25685	DM 1/07
E	CORRECT SPEELING OF "PREPARATION"	27868	DM 14/07

8686

ELECTRICAL CONNECTOR
10-32 THREAD

2 MODEL 060A05
CLAMP NUT
1/4 HEX
M7 X 0.75-6g

1 PRESSURE SENSOR
W/ BUILT IN AMPLIFIER

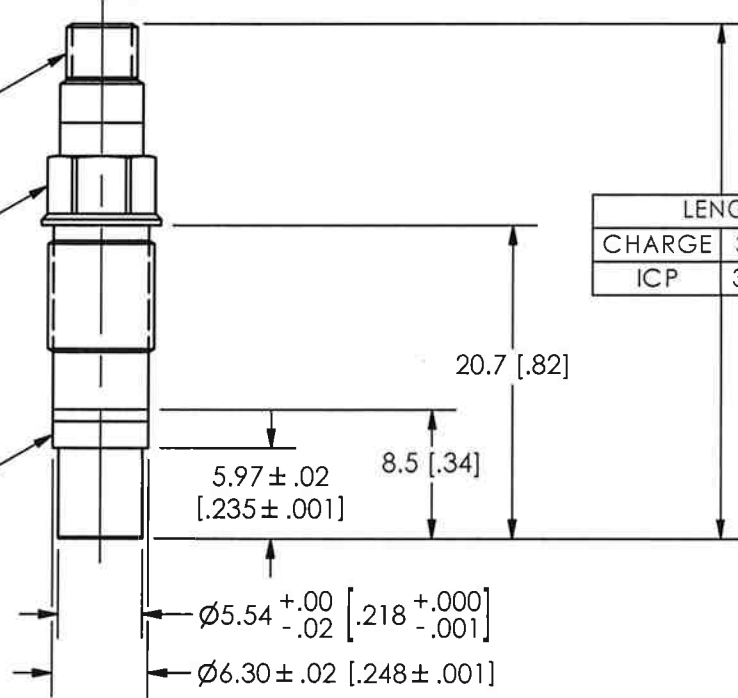

LENGTH	
CHARGE	33.5 [1.32]
ICP	37.1 [1.46]

MOUNTING HOLE PREPARATION

4 FLUSH INSTALLATION
Ø5.61 ± .05 [Ø.221 ± .002]
THRU
└─┬─┐ Ø6.35^{+0.13}_{-.00} [.250^{+0.005}_{-.000}]
X 13.21 [.520] ▽
M7 X 0.75-6H
X 10.16 [.400] ▽
PERFECT THREAD

RECESSED INSTALLATION
└─┬─┐ Ø6.35^{+0.13}_{-.00} [.250^{+0.005}_{-.000}]
X 19.05 [.750] ▽
M7 X 0.75-6H
X 10.16 [.400] ▽
PERFECT THREAD

MODEL 065A02
SEAL
.38 [.015] THICK

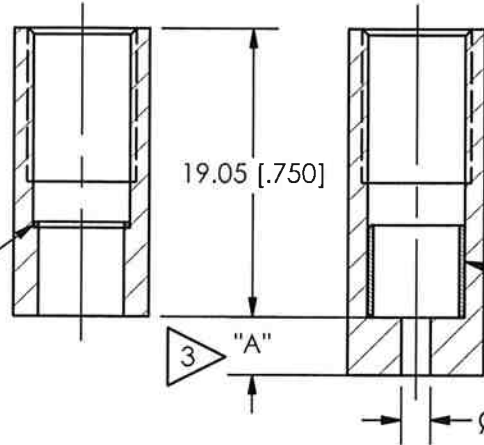

MODEL 065A05
SEAL
6.10 [.240] LONG

4 THESE DIMENSIONS FOR 19.0 [.75] THICK WALL. └─┬─┐ THICKER WALLS TO THIS DIMENSION.

3 DIMENSIONS "A" AND Ø"B" TO SUIT USER REQUIREMENTS.

2 RECOMMENDED TORQUE ON CLAMP NUT 225-395 Ncm [25-35 INCH POUNDS].

1 THIS IS A SEALED ASSEMBLY AND SHOULD BE RETURNED TO THE FACTORY SHOULD SERVICE BECOME NECESSARY.

UNLESS OTHERWISE SPECIFIED TOLERANCES ARE:

DIMENSIONS IN INCHES	DIMENSIONS IN MILLIMETERS [IN BRACKETS]
DECIMALS XX ± .01 XXX ± .005	DECIMALS X ± 0.3 XX ± 0.13
ANGLES ± 2 DEGREES	ANGLES ± 2 DEGREES
FILLETS AND RADII .003 - .005	FILLETS AND RADII [0.07 - 0.13]

DRAWN	ECB	12/26/07	MFG	PRR	12/26/07
CHK'D	DM	12/26/07	ENGR	ECB	12/26/07
APP'D	RF	12/26/07	SALES	MFG	12/26/07

TITLE
INSTALLATION DRAWING
MODELS M111A, M112A, M113A, M113B SERIES
PRESSURE SENSOR

PCB PIEZOTRONICS^{INC}
3425 WALDEN AVE. DEPEW, NY 14043
(716) 684-0001 E-MAIL: sales@pcb.com

CODE IDENT. NO. 52681
DWG. NO. 8686

SCALE: 2X SHEET 1 OF 1

111-1210-90

PCB Piezotronics Inc. claims proprietary rights in the information disclosed hereon. Neither it nor any reproduction thereof will be disclosed to others without the written consent of PCB Piezotronics Inc.

REVISIONS			
REV	DESCRIPTION	ECN	APP'D
P	CORRECT SPELLING OF "PREPARATION"	27868	DM 5/07
R	REMOVE WELD LINE	27890	DM 1/08

ELECTRICAL CONNECTOR
10-32 UNF-2A

3

MODEL 060A03
CLAMP NUT
.25[6.3] HEX
MAT'L: 17-4 (H900)

5/16-24 UNF-2A

4 QUARTZ SENSOR WITH
BUILT IN AMPLIFIER

LENGTH	
CHARGE	1.32[33.5]
ICP	1.48[37.6]

.235 ± .001
[5.97 ± .03]

.34 [8.5]

.81 [20.6]

∅.248 ^{+.000}/_{-.001} [6.30 ^{+.00}/_{-.03}]

∅.218 ^{+.000}/_{-.001} [5.54 ^{+.00}/_{-.03}]

MOUNTING HOLE PREPARATION

1 FLUSH INSTALLATION

∅.221 ± .002 [5.61 ± .05]
THRU
5 ∟∅.250 ^{+.003}/_{-.000} [6.35 ^{+.08}/_{-.00}]
X .520 [13.20] ∇
∟∅.277 [7.04]
X .480 [12.19] ∇
5/16-24 UNF-2B
X .400 [10.16] ∇

2 RECESSED INSTALLATION

5 ∟∅.250 ^{+.003}/_{-.000} [6.35 ^{+.08}/_{-.00}]
X .750 [19.05] ∇
∟∅.277 [7.04]
X .480 [12.19] ∇
5/16-24 UNF-2B
X .400 [10.16] ∇

MODEL 065A02
SEAL
.015 [.38] THK

"A"

MODEL 065A05
SEAL
.240 [6.09] LONG

"B"

5 FOR BEST RESULTS USE A MINIMUM 63 [1.6] SURFACE FINISH.

4 IC AMP AND SENSOR ARE SEALED ASSEMBLIES AND SHOULD BE RETURNED TO THE FACTORY FOR SERVICE AND/OR REPAIR.

3 RECOMMENDED TORQUE ON .25 [6.3] HEX: 25-35 IN. LBS. [2.8-3.9 Nm]

2 DIMENSIONS "A" AND "B" TO SUIT USER REQUIREMENTS.

1 THESE DIMENSIONS FOR .750 [19.05] THICK WALL. COUNTERBORE FOR THICKER WALLS.

UNLESS OTHERWISE SPECIFIED TOLERANCES ARE:

DIMENSIONS IN INCHES	DIMENSIONS IN MILLIMETERS [IN BRACKETS]
DECIMALS XX ± .01 XXX ± .005	DECIMALS X ± 0.3 XX ± 0.13
ANGLES ± 2 DEGREES	ANGLES ± 2 DEGREES
FILLETS AND RADII .003 - .005	FILLETS AND RADII [0.07 - 0.13]

DRAWN	ECB	1/3/08	MFG	JP	1/3/08
CHK'D	DM	1/3/08	ENGR	ECB	1/3/08
APP'D	RF	1/3/08	SALES	RWM	1/3/08
TITLE					
INSTALLATION DRAWING MODELS 111A, 112A, 113A, 113B SERIES PRESSURE SENSOR					

PCB PIEZOTRONICS^{INC}
3425 WALDEN AVE. DEPEW, NY 14043
(716) 684-0001 E-MAIL: sales@pcb.com

CODE IDENT. NO. 52681	DWG. NO. 111-1210-90
SCALE: 2X	SHEET 1 OF 1