



Model 106B50
ICP® Pressure Sensor
Installation and Operating Manual

**For assistance with the operation of this product,
contact PCB Piezotronics, Inc.**

Toll-free: 800-828-8840
24-hour SensorLine: 716-684-0001
Fax: 716-684-0987
E-mail: info@pcb.com
Web: www.pcb.com



The information contained in this document supersedes all similar information that may be found elsewhere in this manual.

Total Customer Satisfaction – PCB Piezotronics guarantees Total Customer Satisfaction. If, at any time, for any reason, you are not completely satisfied with any PCB product, PCB will repair, replace, or exchange it at no charge. You may also choose to have your purchase price refunded in lieu of the repair, replacement, or exchange of the product.

Service – Due to the sophisticated nature of the sensors and associated instrumentation provided by PCB Piezotronics, user servicing or repair is not recommended and, if attempted, may void the factory warranty. Routine maintenance, such as the cleaning of electrical connectors, housings, and mounting surfaces with solutions and techniques that will not harm the physical material of construction, is acceptable. Caution should be observed to insure that liquids are not permitted to migrate into devices that are not hermetically sealed. Such devices should only be wiped with a dampened cloth and never submerged or have liquids poured upon them.

Repair – In the event that equipment becomes damaged or ceases to operate, arrangements should be made to return the equipment to PCB Piezotronics for repair. User servicing or repair is not recommended and, if attempted, may void the factory warranty.

Calibration – Routine calibration of sensors and associated instrumentation is

recommended as this helps build confidence in measurement accuracy and acquired data. Equipment calibration cycles are typically established by the users own quality regimen. When in doubt about a calibration cycle, a good “rule of thumb” is to recalibrate on an annual basis. It is also good practice to recalibrate after exposure to any severe temperature extreme, shock, load, or other environmental influence, or prior to any critical test.

PCB Piezotronics maintains an ISO-9001 certified metrology laboratory and offers calibration services, which are accredited by A2LA to ISO/IEC 17025, with full traceability to N.I.S.T. In addition to the normally supplied calibration, special testing is also available, such as: sensitivity at elevated or cryogenic temperatures, phase response, extended high or low frequency response, extended range, leak testing, hydrostatic pressure testing, and others. For information on standard recalibration services or special testing, contact your local PCB Piezotronics distributor, sales representative, or factory customer service representative.

Returning Equipment – *Following these procedures will insure that your returned materials are handled in the most expedient manner.* Before returning any equipment to PCB Piezotronics, contact your local distributor, sales representative, or factory customer service representative to obtain a Return

Materials Authorization (RMA) Number. This RMA number should be clearly marked on the outside of all package(s) and on the packing list(s) accompanying the shipment. A detailed account of the nature of the problem(s) being experienced with the equipment should also be included inside the package(s) containing any returned materials.

A Purchase Order, included with the returned materials, will expedite the turn-around of serviced equipment. It is recommended to include authorization on the Purchase Order for PCB to proceed with any repairs, as long as they do not exceed 50% of the replacement cost of the returned item(s). PCB will provide a price quotation or replacement recommendation for any item whose repair costs would exceed 50% of replacement cost, or any item that is not economically feasible to repair. For routine calibration services, the Purchase Order should include authorization to proceed and return at current pricing, which can be obtained from a factory customer service representative.

Warranty – All equipment and repair services provided by PCB Piezotronics, Inc. are covered by a limited warranty against defective material and workmanship for a period of one year from date of original purchase. Contact

PCB for a complete statement of our warranty. Expendable items, such as batteries and mounting hardware, are not covered by warranty. Mechanical damage to equipment due to improper use is not covered by warranty. Electronic circuitry failure caused by the introduction of unregulated or improper excitation power or electrostatic discharge is not covered by warranty.

Contact Information – International customers should direct all inquiries to their local distributor or sales office. A complete list of distributors and offices can be found at www.pcb.com. Customers within the United States may contact their local sales representative or a factory customer service representative. A complete list of sales representatives can be found at www.pcb.com. Toll-free telephone numbers for a factory customer service representative, in the division responsible for this product, can be found on the title page at the front of this manual. Our ship to address and general contact numbers are:

PCB Piezotronics, Inc.
3425 Walden Ave.
Depew, NY 14043 USA
Toll-free: (800) 828-8840
24-hour SensorLineSM: (716) 684-0001
Website: www.pcb.com
E-mail: info@pcb.com

OPERATION MANUAL FOR HIGH INTENSITY MICROPHONES MODELS 106B, 106B10, 106B50

1.0 INTRODUCTION

The Series 106B microphones feature high-sensitivity, acceleration-compensated quartz pressure elements coupled to built-in integrated circuit impedance converting amplifiers.

These very sensitive sensors are designed to measure pressure perturbations in air or in fluids in severe environments. They can also be used to measure very small pressure disturbances on a much higher static head, with certain precautions.

2.0 DESCRIPTION

The quartz elements in the 106B Series utilize a special cut in quartz to produce a proportionately higher output voltage than the standard X-cut compression crystals normally used.

A built-in seismic mass acting on another quartz crystal effectively cancels the spurious signal produced by the mass of the diaphragm and end piece acting upon the very sensitive crystals in the presence of axial vibration inputs.

This design produces an extremely high level output signal with good resolution, relatively free from unwanted vibration effects.

As with all quartz sensors, the high rigidity results in negligible diaphragm motion producing excellent linearity from the threshold pressure to full-scale pressure. The high rigidity of quartz also results in sensors with high natural frequency, giving a very wide useful frequency range.

Although the same basic quartz element is used in both models, the sensitivity of the 106B50 is twice that of the 106B, the result of a larger diaphragm area in the B50.

The Model 106B10 consists of the Model 106B element in a customized package specifically designed for paper mill headbox measurements. The built-in electronics consist of a low-noise MOSFET input source follower with unity gain. A single wire feeds constant current power to the source of the FET and also carries the dynamic signal, superimposed on the +3 to +5 bias.

See "Guide to ICP[®] Instrumentation, G-0001B" for a more complete treatment of the "Integrated Circuit Piezoelectric" (ICP[®]) concept.

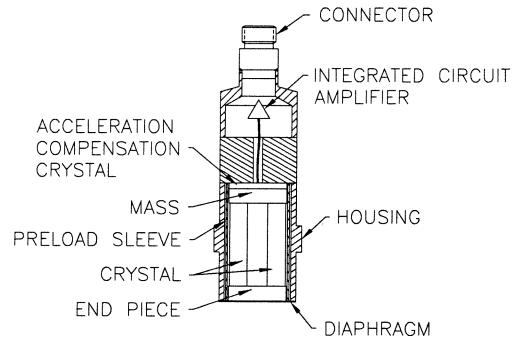

Cross Section: Series 106B Microphone Element

3.0 POLARITY

Both models produce a positive-going output signal with increasing pressure at the diaphragm. Since the bias voltage of the low-noise electronics is rather low compared to other ICP[®] instruments, the output voltage capability is nonsymmetrical, i.e. the units can produce positive-going voltages to 12 or 13 volts with a +18 V battery supply, but the linear negative-going output voltage is limited to approximately 2.5 volts.

This is not a disadvantage because +2.5 volts provide an adequate output signal for most microphone applications and the higher positive-going voltage affords an ability to measure much higher positive-going pulses if desirable.

4.0 POWER UNITS

In general, it is advisable to use battery-powered signal conditioners (such as the 480C02) to power the Series 106 microphones because of their inherently low noise.

If line powering is desirable, consult the factory for help in selecting the best signal conditioner for the application.

OPERATION MANUAL FOR HIGH INTENSITY MICROPHONES MODELS 106B, 106B10, 106B50

These sensors must only be powered through constant-current diodes or other equivalent current-limiting circuitry, (2 to 20 mA) as contained in all PCB signal conditioners.

CAUTION: Never apply power directly to the center pin of the connector without the current-limiting protection (2 mA maximum), as to do so will destroy the built-in amplifier.

Connect the microphones to the power unit as shown in the figure below.

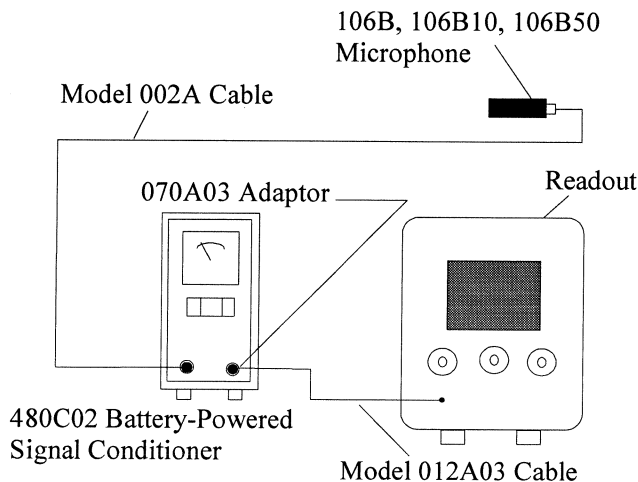

Typical Power Connection

The 106B, 106B10, and 106B50 differ from the standard ICP[®] sensors in that the low noise, built-in amplifiers have a +3 to +5 V bias or turn-on voltage instead of the usual +11 V bias. Consequently, the bias monitor voltmeter located on the front panel of most PCB signal conditioners will indicate approximately 20% full scale under normal operating conditions, rather than the mid-scale reading associated with normal operation for other ICP[®] instruments.

A full-scale reading on the bias monitor meter indicates an open circuit between the signal conditioner and sensor.

A zero reading indicates a short circuit in cable, connections, or sensor.

5.0 INSTALLATION

Consult the applicable installation drawing at the front of this manual for details on the preparation of mounting ports. For best high-frequency response, flush mounting of the diaphragm is desirable.

The standard type of mounting arrangement for these microphones is by use of the hollow clamp nut supplied (refer to installation drawing), but other methods of mounting the units are acceptable.

Non-metallic mounting adaptors for off-ground installations are available. Consult factory with your specific installation problem.

6.0 CALIBRATION

The 106B, 106B10, and 106B50 are calibrated by dynamic means over the full range by subjecting the unit to a series of calibrated pneumatic pressure steps. In addition, the units are given a 124 dB sound pressure level calibration at 250 Hz with a pistonphone. An electrostatic calibration is used to verify the sensor's frequency response.

Recalibration service is offered by PCB. Consult the factory for details.

7.0 MEASURING SMALL PRESSURE FLUCTUATIONS ON A HIGH STATIC HEAD

It is possible to measure small dynamic pressure variations superimposed upon a high static (pneumatic or hydraulic) head, but care must be exercised during application and removal of the static pressure to avoid destroying the input MOSFET amplifier.

The important point is to apply and release the static head slowly to allow the resistor across the quartz crystal to bleed off the charge and avoid a voltage build-up that can punch through the gate structure of the MOSFET, rendering it inoperative. (Approximately 100 V maximum rating.)

**OPERATION MANUAL FOR
HIGH INTENSITY MICROPHONES
MODELS 106B, 106B10, 106B50**

For the high sensitivity 106B50 (500 mV/psi), keep the rate of pressure application and removal below 200 psi/sec and do not exceed the maximum pressure rating of the unit. Remember that this rate must not be exceeded during removal of the static head as well as during application.

©ICP is a registered trademark of PCB Piezotronics

For the lower sensitivity 106B and 106B10, do not exceed a pressure application or removal rate of 300 psi/sec.

After the high static head is applied, allow time for all coupling capacitors in the readout circuit to fully charge (signified by an end to the apparent "drift" of the output signal), then proceed with the measurement.

8.0 MAINTENANCE

The sealed construction of the 106B Series precludes field maintenance and repair.

Should the time constant degrade or should an abnormality appear in the normal bias voltage, bake the unit in a +250 °F oven for 1 to 2 hours, then retest.

If this does not remove the problem, or should other problems occur, contact the factory for assistance in tracing the problem or for instructions on returning the unit for repair or replacement.

9.0 PRECAUTIONS

1. Do not apply voltage to the units without a current-limiting device (20 mA maximum) in the line, such as is incorporated in all PCB signal conditioners. To do so will destroy the built-in amplifier.
2. Do not subject these sensors to temperatures exceeding 250 °F.
3. Use caution when applying and releasing high static pressures (as outlined in Section 7.0 of this guide) to avoid destroying built-in amplifier.
4. Do not exceed maximum pressure rating.

Model Number
106B50

ICP® PRESSURE SENSOR

Revision: M
ECN #: 29520

	ENGLISH	SI
Performance		
Measurement Range(for ±2.5V output)	5 psi	34.45 kPa
Sensitivity(± 15 %)	500 mV/psi	72.5 mV/kPa
Maximum Pressure(step)	100 psi	690 kPa
Maximum Pressure(static)	500 psi	3448 kPa
Resolution	0.07 mpsi	0.00048 kPa
Resonant Frequency	≥ 40 kHz	≥ 40 kHz
Rise Time	≤ 12 μ sec	≤ 12 μ sec
Low Frequency Response(-5 %)	0.5 Hz	0.5 Hz
Non-Linearity	≤ 1 % FS	≤ 1 % FS
Environmental		
Acceleration Sensitivity	≤ 0.002 psi/g	≤ 0.0014 kPa/(m/s ²)
Temperature Range(Operating)	-65 to +250 °F	-54 to +121 °C
Temperature Coefficient of Sensitivity	≤ 0.03 %/°F	≤ 0.054 %/°C
Maximum Flash Temperature	3000 °F	1649 °C
Maximum Vibration	500 g pk	4903 m/s ² pk
Maximum Shock	1000 g pk	9807 m/s ² pk
Electrical		
Output Polarity(Positive Pressure)	Positive	Positive
Discharge Time Constant(at room temp)	≥ 1 sec	≥ 1 sec
Excitation Voltage	11 to 30 VDC	11 to 30 VDC
Constant Current Excitation	2 to 20 mA	2 to 20 mA
Output Impedance	≤ 100 ohm	≤ 100 ohm
Output Bias Voltage	3 to 8 VDC	3 to 8 VDC
Physical		
Sensing Element	Quartz	Quartz
Housing Material	17-4 Stainless Steel	17-4 Stainless Steel
Diaphragm	316L Stainless Steel	316L Stainless Steel
Sealing	Welded Hermetic	Welded Hermetic
Electrical Connector	10-32 Coaxial Jack	10-32 Coaxial Jack
Weight	1.13 oz	32 gm

OPTIONAL VERSIONS
Optional versions have identical specifications and accessories as listed for the standard model except where noted below. More than one option may be used.

E - Emralon coating
Coating Emralon Emralon
Electrical Isolation 10⁸ ohm 10⁸ ohm

W - Water Resistant Cable [3]
Supplied Accessory : Model 060A11 Delrin clamp nut 3/4-16-2A thd 3/4" hex (1)

WM - Water Resistant Cable [3]
Supplied Accessory : Model 060A13 Metric Delrin clamp nut M20 x 1.5-6g thd 20 mm hex (1)

NOTES:
[1] Zero-based, least-squares, straight line method.
[2] See PCB Declaration of Conformance PS023 for details.
[3] Clamp nut installed prior to cable attachment

SUPPLIED ACCESSORIES:
Model 060A11 Delrin clamp nut 3/4-16-2A thd 3/4" hex
Model 060A13 Metric Delrin clamp nut M20 x 1.5-6g thd 20 mm hex (1)
Model 065A36 Seal, .687" OD x .625" ID x .060", Derlin (3)

Entered: <i>BLS</i>	Engineer: <i>NJL</i>	Sales: <i>RWH</i>	Approved: <i>RF</i>	Spec Number:
Date: <i>10/17/08</i>	Date: <i>10/2/08</i>	Date: <i>10/3/08</i>	Date: <i>10/2/08</i>	106-2500-80



All specifications are at room temperature unless otherwise specified.
In the interest of constant product improvement, we reserve the right to change specifications without notice.
ICP® is a registered trademark of PCB Group, Inc.

PCB PIEZOTRONICS™
PRESSURE DIVISION
3425 Walden Avenue, Depew, NY 14043

Phone: 716-684-0001
Fax: 716-686-9129
E-Mail: pressure@pcb.com

106-2500-92

PCB Piezotronics Inc. claims proprietary rights in the information disclosed hereon. Neither it, nor any reproduction thereof will be disclosed to others without written consent of PCB Piezotronics Inc.

APPLICATION

NEXT ASS'Y	USED ON	VAR

REVISIONS

REV	DESCRIPTION	ECN	DATE	APP'D
C	REVISED PER ECN	8320	10/14/97	Ken L.

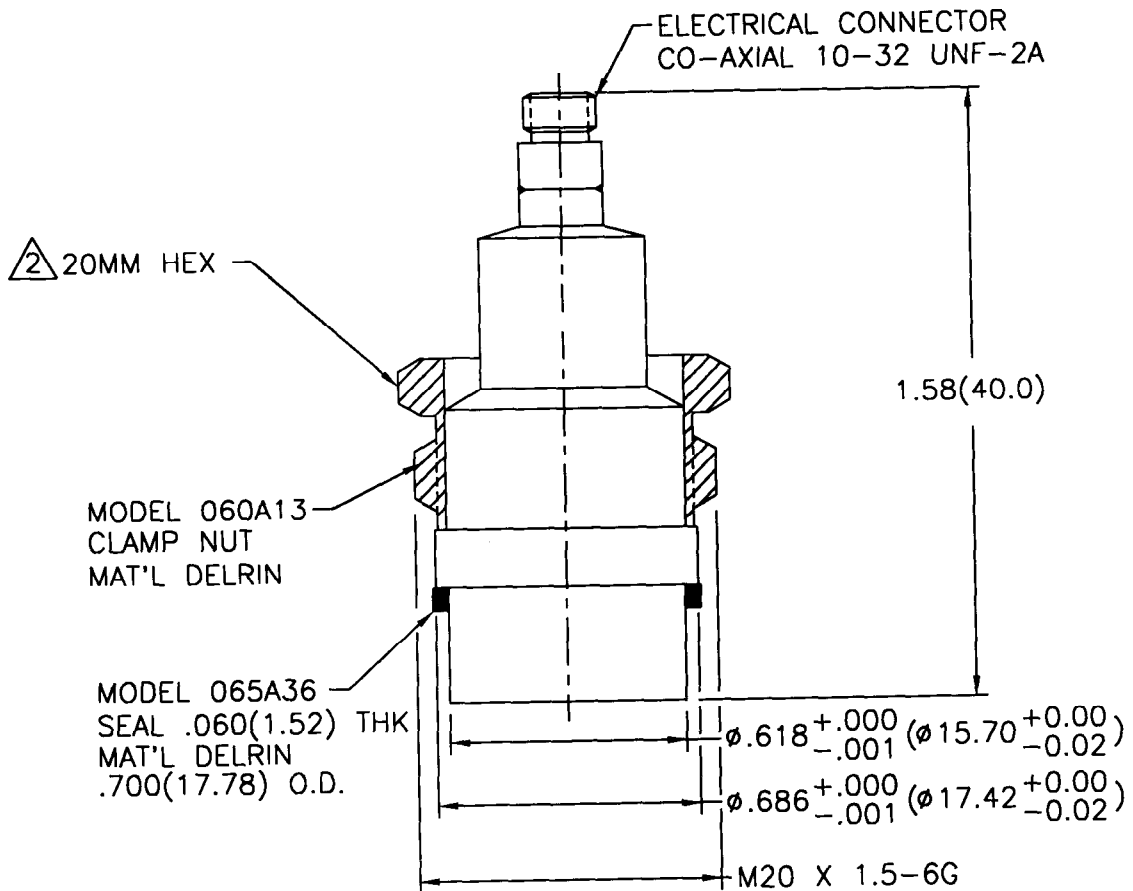

MOUNTING HOLE PREPARATION

DRILL $\phi .625(\phi 15.88)$
THRU
 $\square \phi .718(\phi 18.24)$
 X .460(11.68) ∇
 TAP M20-1.50-6H
 X .28(7.11) ∇

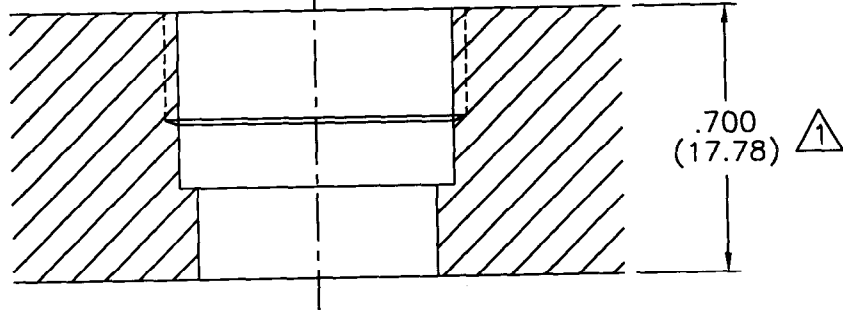

- 2** RECOMMENDED MOUNTING TORQUE ON 20MM HEX 3-5 FT LBS. (.415-.691 METER KILOGRAMS)
- 1** DIMENSIONS SHOWN ARE FOR .700(17.78) THICK WALL. COUNTERBORE THICKER WALLS.

UNLESS SPECIFIED TOLERANCES		DRAWN	10/14/97	MFG	Dec	10/14/97	PCB PIEZOTRONICS, INC. 3425 WALDEN AVE. DEPEW, NEW YORK 14043 PHONE: (716) 684-0001
DIMENSIONS IN INCHES	DIMENSIONS IN MILLIMETERS (IN PARENTHESIS)	CHK'D	Ken L.	ENGR	ACT	10/14/97	
DECIMALS XX ± .01 XXX ± .005	DECIMALS XX ± 0.3 XXX ± 0.13	APP'D	Ken L.	SAN	Ken L.	10/14/97	
ANGLES ± 2 DEGREES	ANGLES ± 2 DEGREES	TITLE		INSTALLATION DRAWING		CODE IDENT. NO.	DWG. NO.
FILLETS AND RADII .003 - .005	FILLETS AND RADII (0.07 - 0.13)			MODEL M106B50		52681	106-2500-92
DD011 REV. A 05/26/95				OFF-GND PRESSURE SENSOR		SCALE: 2X	SHEET 1 OF 1

106-2500-90

PCB Piezotronics Inc. claims proprietary rights in the information disclosed hereon. Neither this nor any reproduction thereof will be disclosed to others without written consent of PCB Piezotronics Inc.

APPLICATION		
NEXT ASS'Y	USED ON	VAR

REVISIONS				
REV	DESCRIPTION	ECN	DATE	APP'D
E	REVISED PER ECN	8320	10/14/97	KenL

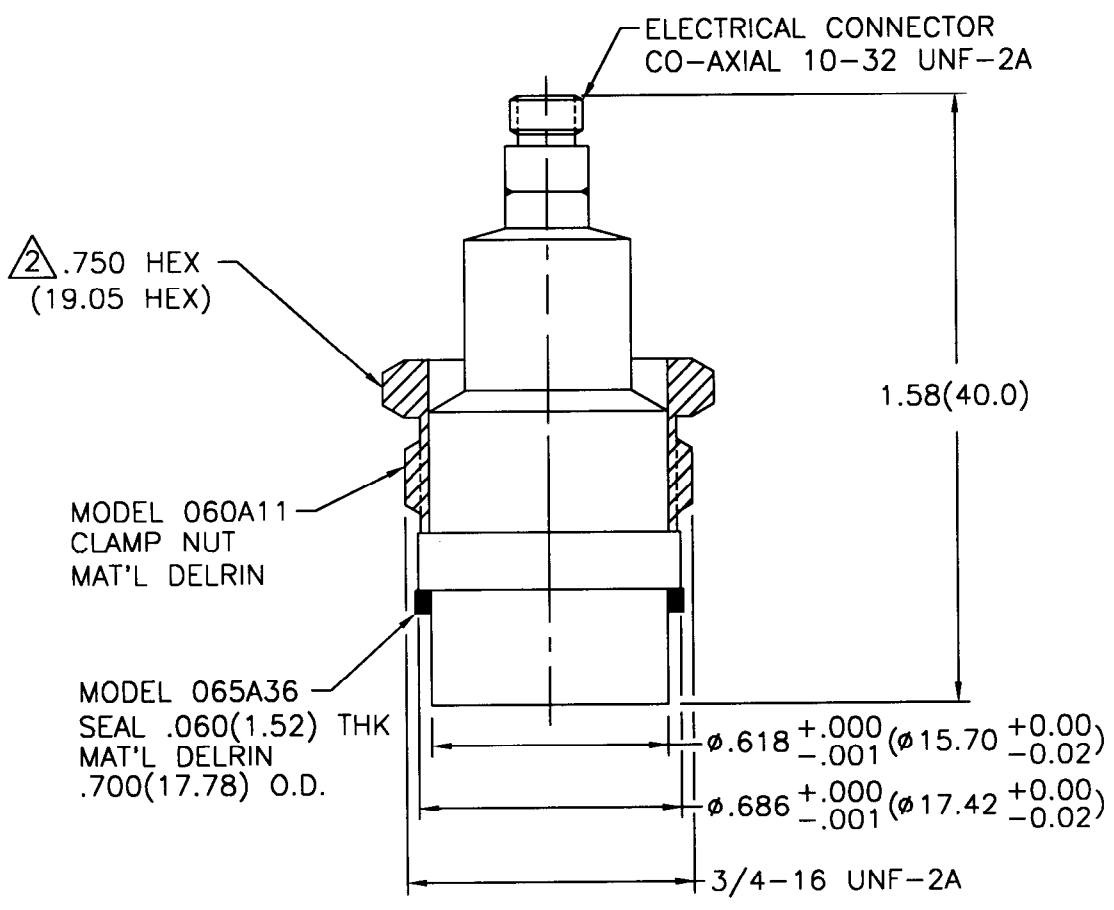

MOUNTING HOLE PREPARATION

- DRILL $\phi .625(\phi 15.88)$
- THRU
- $\square \phi .703(\phi 17.86)$
- X .460(11.68) ∇
- TAP 3/4-16 UNF-2B
- X .28(7.1) ∇

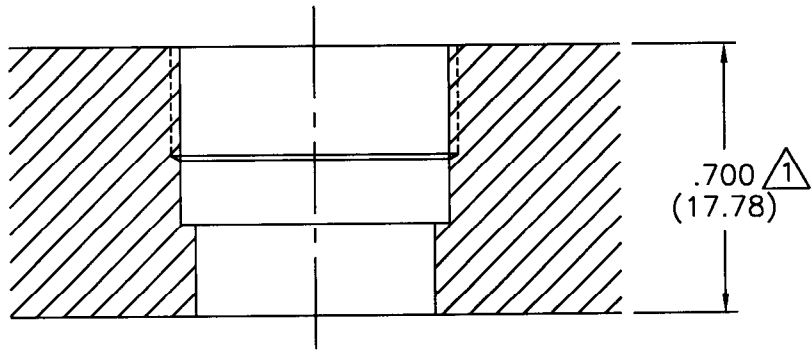

- 2 RECOMMENDED MOUNTING TORQUE ON 3/4 HEX 3-5 FT LBS (.415-.691 METER KILOGRAMS).
- 1 DIMENSIONS SHOWN ARE FOR .700(17.78) THICK WALL. COUNTERBORE THICKER WALLS.

UNLESS SPECIFIED TOLERANCES		DRAWN		MFG		PCB PIEZOTRONICS, INC.	
DIMENSIONS IN INCHES	DIMENSIONS IN MILLIMETERS (IN PARENTHESIS)	CHK'D	KenL	10/14/97	ENGR	ACT	10/14/97
DECIMALS XX $\pm .01$	DECIMALS XX ± 0.3	APP'D	KenL	10/14/97	Sub	PPR	10/14/97
XXX $\pm .005$	XXX ± 0.13	TITLE				CODE	DWG. NO.
ANGLES ± 2 DEGREES	ANGLES ± 2 DEGREES	INSTALLATION DRAWING				52681	106-2500-90
FILLET AND RADII .003 - .005	FILLET AND RADII (0.07 - 0.13)	MODEL 106B50				SCALE: 2X SHEET 1 OF 1	
DD011 REV. A 05/26/95		OFF-GND PRESSURE SENSOR					