



Model 105C22
ICP® Pressure Sensor
Installation and Operating Manual

**For assistance with the operation of this product,
contact PCB Piezotronics, Inc.**

Toll-free: 800-828-8840
24-hour SensorLine: 716-684-0001
Fax: 716-684-0987
E-mail: info@pcb.com
Web: www.pcb.com



The information contained in this document supersedes all similar information that may be found elsewhere in this manual.

Total Customer Satisfaction – PCB Piezotronics guarantees Total Customer Satisfaction. If, at any time, for any reason, you are not completely satisfied with any PCB product, PCB will repair, replace, or exchange it at no charge. You may also choose to have your purchase price refunded in lieu of the repair, replacement, or exchange of the product.

Service – Due to the sophisticated nature of the sensors and associated instrumentation provided by PCB Piezotronics, user servicing or repair is not recommended and, if attempted, may void the factory warranty. Routine maintenance, such as the cleaning of electrical connectors, housings, and mounting surfaces with solutions and techniques that will not harm the physical material of construction, is acceptable. Caution should be observed to insure that liquids are not permitted to migrate into devices that are not hermetically sealed. Such devices should only be wiped with a dampened cloth and never submerged or have liquids poured upon them.

Repair – In the event that equipment becomes damaged or ceases to operate, arrangements should be made to return the equipment to PCB Piezotronics for repair. User servicing or repair is not recommended and, if attempted, may void the factory warranty.

Calibration – Routine calibration of sensors and associated instrumentation is

recommended as this helps build confidence in measurement accuracy and acquired data. Equipment calibration cycles are typically established by the users own quality regimen. When in doubt about a calibration cycle, a good “rule of thumb” is to recalibrate on an annual basis. It is also good practice to recalibrate after exposure to any severe temperature extreme, shock, load, or other environmental influence, or prior to any critical test.

PCB Piezotronics maintains an ISO-9001 certified metrology laboratory and offers calibration services, which are accredited by A2LA to ISO/IEC 17025, with full traceability to N.I.S.T. In addition to the normally supplied calibration, special testing is also available, such as: sensitivity at elevated or cryogenic temperatures, phase response, extended high or low frequency response, extended range, leak testing, hydrostatic pressure testing, and others. For information on standard recalibration services or special testing, contact your local PCB Piezotronics distributor, sales representative, or factory customer service representative.

Returning Equipment – *Following these procedures will insure that your returned materials are handled in the most expedient manner.* Before returning any equipment to PCB Piezotronics, contact your local distributor, sales representative, or factory customer service representative to obtain a Return

Materials Authorization (RMA) Number. This RMA number should be clearly marked on the outside of all package(s) and on the packing list(s) accompanying the shipment. A detailed account of the nature of the problem(s) being experienced with the equipment should also be included inside the package(s) containing any returned materials.

A Purchase Order, included with the returned materials, will expedite the turn-around of serviced equipment. It is recommended to include authorization on the Purchase Order for PCB to proceed with any repairs, as long as they do not exceed 50% of the replacement cost of the returned item(s). PCB will provide a price quotation or replacement recommendation for any item whose repair costs would exceed 50% of replacement cost, or any item that is not economically feasible to repair. For routine calibration services, the Purchase Order should include authorization to proceed and return at current pricing, which can be obtained from a factory customer service representative.

Warranty – All equipment and repair services provided by PCB Piezotronics, Inc. are covered by a limited warranty against defective material and workmanship for a period of one year from date of original purchase. Contact

PCB for a complete statement of our warranty. Expendable items, such as batteries and mounting hardware, are not covered by warranty. Mechanical damage to equipment due to improper use is not covered by warranty. Electronic circuitry failure caused by the introduction of unregulated or improper excitation power or electrostatic discharge is not covered by warranty.

Contact Information – International customers should direct all inquiries to their local distributor or sales office. A complete list of distributors and offices can be found at www.pcb.com. Customers within the United States may contact their local sales representative or a factory customer service representative. A complete list of sales representatives can be found at www.pcb.com. Toll-free telephone numbers for a factory customer service representative, in the division responsible for this product, can be found on the title page at the front of this manual. Our ship to address and general contact numbers are:

PCB Piezotronics, Inc.
3425 Walden Ave.
Depew, NY 14043 USA
Toll-free: (800) 828-8840
24-hour SensorLineSM: (716) 684-0001
Website: www.pcb.com
E-mail: info@pcb.com

**OPERATION MANUAL FOR
MINIATURE ICP® PRESSURE SENSOR
105A AND 105C SERIES**

1.0 INTRODUCTION

This model series is designed to satisfy the need for measurement of dynamic pressures where space is limited, such as in model testing.

The series consists of three basic mechanical configurations or styles, each featuring a .099" diameter diaphragm and each with a built-in impedance-converting amplifier for simple, convenient, two-wire, low-impedance operation.

2.0 DESCRIPTION

The Series 105A sensors utilize two quartz discs in a thickness compression mode to produce a high-impedance level signal which is impressed across the input of a microminiature impedance converter built into the sensor housing.

The signal is superimposed upon a +11 volt (nominal) bias level at the amplifier output and is normally decoupled from the bias voltage in the power unit.

This signal can be fed directly into most common readout instruments such as oscilloscopes, digital voltmeters, AC meters, peak meters, recorders, etc. The output impedance is less than 100 ohms.

Consult guide G-0001B "General Guide to ICP® Instrumentation" for a more complete treatment of the ICP® (Integrated Circuit Piezoelectric) principle.

3.0 INSTALLATION

Because of the miniature size of these units, extra care should be exercised in preparation of mounting ports and in installation of sensors into the ports.

Individual dimensional, performance and installation drawings are included in the manual for each particular model. Adhere carefully to instructions on these drawings.

It is not necessary to use low-noise treated coaxial cable as with high-impedance type sensors. PCB Model 002A Cable is recommended.

3.1 MODEL 105A

This is the smallest of the three styles and it is supplied in only the 100 psi range.

The Model 105A is normally mounted using Model 060A04 Clamp Nut (supplied); however, if lack of space precludes the use of the clamp nut, the sensor may be epoxied in place if necessary.

Do not over torque clamp nut, as to do so may distort the body of the sensor and affect the sensitivity of the device.

The electrical connection to this model is made by soldering the positive (center conductor) lead from the power unit to the .040 diameter solder terminal provided.

(IMPORTANT! See Section 8.0, page 4)

NOTE: Do not overheat this terminal. Use a small iron with only enough heat to obtain good solder joint.

The electrical ground return is made to the sensor body. This connection can be made by attaching electrically to the structure or by using the metal ribbon spotwelded to the sensor body.

3.2 MODELS 105C02, C12 & C22

This style utilizes a 10-32 external thread to facilitate mounting. It is supplied in three full-scale ranges: 100, 1000 and 5000 psi.

Prepare mounting port in accordance with installation drawing provided in manual. Do not over torque. Use only enough torque to obtain a seal.

The electrical connection is made via a 5-44 coaxial connector. Use coaxial 002G10 cable, 5-44 to 10-32 microdot.

OPERATION MANUAL FOR MINIATURE ICP® PRESSURE SENSOR 105A AND 105C SERIES

3.3 MODELS 105C03, C13, 23, C33, C43

This style is the largest and is supplied in five models with full-scale ranges to 100, 1000, 5000, 10,000 and 30,000 psi.

The electrical connection to this style sensor is made via a 10-32 coaxial connector.

3.4 FLASH TEMPERATURE PROTECTION

It is good practice to protect the diaphragm against flash thermal effects, especially when flush-mounted, to minimize spurious outputs generated by high heat influx due to blasts, high compression heating, etc.

One or more layers of black vinyl electrical tape on the diaphragm can be useful for this purpose in many cases. RTV-type silicone rubber has also proven effective.

Experimentation is the best method for determination of effectiveness of protective material for each sensor application.

3.5 RECESSED INSTALLATION

If ultra-high frequency response is not needed, it is good practice to use a recessed diaphragm installation.

Because of its one-piece machined diaphragm construction, the 105A series is sensitive over its entire frontal area. Use extreme care when preparing recessed installation port to ensure that no particles, burrs or other residue are entrapped in the .010" gap ahead of the diaphragm. Force on the diaphragm due to such entrapped particles may change the calibration of the sensor.

Recessed mounting protects the sensor diaphragm from the effects of high-flash temperatures and particle impingement due to blast effects, thereby prolonging sensor life.

The limitation is that this type of installation lies in the high-frequency limiting effects of the passage, due to its length.

The passage behaves like an underdamped second order system, the resonant frequency being determined by the passage length. This can have a limiting effect on pressure pulse rise time while causing passage ringing in cases where the passage is too long with respect to pulse rise time. (See chart below.)

The following relationship determines this resonant frequency (f_r):

$$f_r = \frac{V}{4L} \quad (\text{Hz}) \quad (\text{Eq. 1})$$

Where: f_r = Resonant frequency of passage (Hz)

V = Velocity of sound in air (ft/sec)

L = Length of column (ft)

For air at room temperature, (Eq. 1) becomes:

$$f_r = \frac{3300}{L}$$

Where L = Passage length (in.)

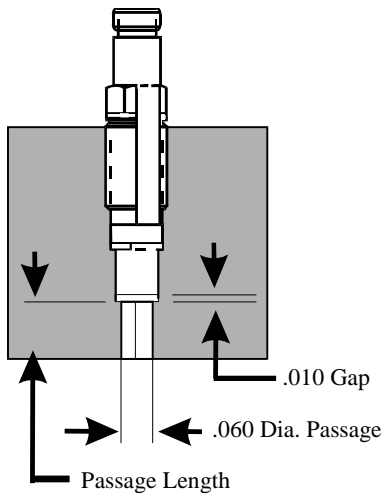

Typical Recessed Installation

OPERATION MANUAL FOR MINIATURE ICP® PRESSURE SENSOR 105A AND 105C SERIES

The natural frequency and approximate fastest pressure step rise time for various length passages is shown in the following chart. (Medium, air at 25°C).

PASSAGE LENGTH (in.)	PASSAGE RESONANCE (kHz)	APPROX. FASTEST PULSE RISE TIME (u Sec)
.050	66	5
.100	33	10
.200	16.5	20
.50	6.6	50
1.0	3.3	100

Passage Resonance vs. Passage Length

Actual resonant frequencies measured in practice may differ slightly from the chart values due to variations in the velocity of propagation of sound caused by changes in temperature and pressure of the medium in the passage.

For best matching of passage to diaphragm, maintain the .010" clearance ahead of the diaphragm as shown in Typical Recessed Installation figure.

4.0 OPERATION

Connect sensor to signal conditioner as shown below, depending upon sensor style being used.

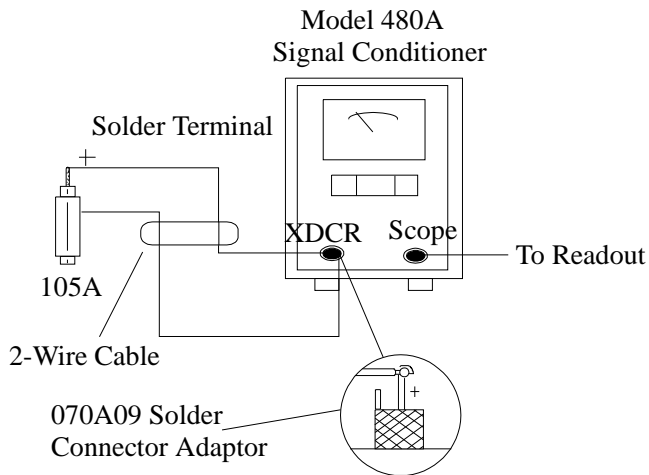

Typical Circuit Connection (For 105A)

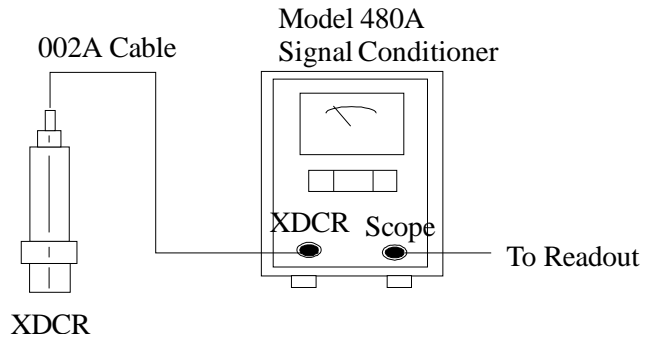

Typical Circuit Connection (For 105C02,C03, C12, C13, C22, C23, C33, C43)

NOTE: All PCB signal conditioners for ICP® sensor contain current-limiting circuitry to set the input current in the range of 2 to 20 mA.

Do not connect a power supply to these units without current limiting. To do so will destroy the built-in IC amplifier.

All PCB signal conditioners feature fault-monitoring voltmeters on the front panel. During normal operation, the meter will indicate about mid-scale (+11 volts). If one of the connections to the sensor is open, the meter will read full scale (yellow area). Should a short occur on the sensor line, the meter will read 0 volts (red area).

5.0 CALIBRATION

Because of the relatively short discharge time constant of this series, static calibration means cannot be used. Fast dynamic means such as step function or pulse generators must be used instead.

Contact the factory for help in solving specific calibration problems.

6.0 MAINTENANCE

The small size and sealed construction of these sensors precludes field maintenance and repair. Should a problem develop, contact the factory for assistance.

**OPERATION MANUAL FOR
MINIATURE ICP® PRESSURE SENSOR
105A AND 105C SERIES**

7.0 CAUTIONS

1. Do not apply voltage to the electrical terminals without current-limiting protection.
2. Do not apply more than 30 VDC to the sensor.
3. Do not put more than 20 mA current into the input terminals.
4. Do not overtorque sensors when installing.
5. Do not apply too much heat to the solder pin of style 1.

8.0 TERMINAL LEAD AND GROUND

To eliminate any possibility of overheating the solder terminal and destroying the microamplifier in the sensor, a 2.0 inch long insulated wire has been provided on the solder terminal for soldering a connector lead from the power unit. The ground return is provided by a metal ribbon (.003 x .020) welded to the Model 060A04 clamp nut.

	ENGLISH	SI	
Performance			
Measurement Range(for ±5V output)	5 kpsi	34,475 kPa	
Sensitivity(± 15 %)	1.0 mV/psi	0.145 mV/kPa	[1]
Maximum Pressure	7.5 kpsi	51,713 kPa	
Resolution	100 mpsi	0.69 kPa	
Resonant Frequency	≥ 250 kHz	≥ 250 kHz	
Rise Time	≤ 2 μ sec	≤ 2 μ sec	
Low Frequency Response(-5 %)	0.5 Hz	0.5 Hz	
Non-Linearity	≤ 2 % FS	≤ 2 % FS	[2]
Environmental			
Acceleration Sensitivity	≤ 0.04 psi/g	≤ 0.028 kPa/(m/s ²)	
Temperature Range(Operating)	-100 to +250 °F	-73 to +121 °C	
Temperature Coefficient of Sensitivity	≤ 0.09 %/°F	≤ 0.162 %/°C	
Maximum Flash Temperature	3000 °F	1649 °C	
Maximum Shock	5000 g pk	49,035 m/s ² pk	
Electrical			
Output Polarity(Positive Pressure)	Positive	Positive	
Discharge Time Constant(at room temp)	≥ 1.0 sec	≥ 1.0 sec	
Excitation Voltage	22 to 30 VDC	22 to 30 VDC	
Constant Current Excitation	2 to 20 mA	2 to 20 mA	
Output Impedance	<100 ohm	<100 ohm	
Output Bias Voltage	8 to 14 VDC	8 to 14 VDC	
Physical			
Sensing Geometry	Compression	Compression	
Sensing Element	Quartz	Quartz	
Housing Material	Stainless Steel	Stainless Steel	
Diaphragm	17-4 Stainless Steel	17-4 Stainless Steel	
Sealing	Welded Hermetic	Welded Hermetic	
Electrical Connector	5-44 Coaxial	5-44 Coaxial	
Weight	0.055 oz	1.56 gm	

OPTIONAL VERSIONS

Optional versions have identical specifications and accessories as listed for the standard model except where noted below. More than one option may be used.

M - Metric Mount

N - Negative Output Polarity

W - Water Resistant Cable

NOTES:

[1] Due to high sensitivity, the static pressure should be applied and removed very slowly.

[2] Zero-based, least-squares, straight line method.

[3] See PCB Declaration of Conformance PS023 for details.

SUPPLIED ACCESSORIES:

Model 018C10 Miniature coaxial cable, vinyl insulation jacket, 10-ft, 5-44 coaxial plug to BNC plug (1)

Model 040A37 Hex nut driver (1)

Model 065A10 Seal ring 0.138" OD x 0.101" ID x 0.022" thk brass (3)

Model 065A38 Seal & Sleeve 0.138" OD x 0.101" ID x 0.105" thk., brass. (3)

Entered: <u>BLS</u>	Engineer: <u>RF</u>	Sales: <u>RWM</u>	Approved: <u>NJL</u>	Spec Number:
Date: <u>8-6-07</u>	Date: <u>8-3-07</u>	Date: <u>8-3-07</u>	Date: <u>8-3-07</u>	11322



*All specifications are at room temperature unless otherwise specified.
In the interest of constant product improvement, we reserve the right to change specifications without notice.*

ICP® is a registered trademark of PCB Group, Inc.

PCB PIEZOTRONICS™

PRESSURE DIVISION

3425 Walden Avenue, Depew, NY 14043

Phone: 716-684-0001
 Fax: 716-686-9129
 E-Mail: pressure@pcb.com

11563

PCB Piezotronics Inc. claims proprietary rights in the information disclosed hereon. Neither it nor any reproduction thereof will be disclosed to others without written consent of PCB Piezotronics Inc.

APPLICATION		
NEXT ASS'Y	USED ON	VAR

REVISIONS				
REV	DESCRIPTION	ECN	DATE	APP'D

ELECTRICAL CONNECTOR
COAXIAL 5-44 UNF-2A

④ .156(4.00) HEX

10-32 UNF-2A

MODEL 065A10 SEAL
.022(.56) THICK
MATERIAL: BRASS
(SUPPLIED)

$.099^{+.000}_{-.001}$ (2.51 $^{+0.00}_{-0.03}$)

$.140^{+.000}_{-.001}$ (3.57 $^{+0.00}_{-0.03}$)

.11(2.8)

∅.190(∅4.83)

.90(22.9)

.27(6.9)

$.100^{+.000}_{-.001}$ (2.54 $^{+0.00}_{-0.03}$)

MOUNTING HOLE PREPARATION:

- ∅.101(∅2.57) THRU ③
- └ ∅.140(∅3.57) ③
- X $.190^{+.000}_{-.005}$ (4.83 $^{+0.00}_{-0.13}$) ∇ ②
- └ ∅.159(∅4.04)
- X $.175^{+.000}_{-.005}$ (4.45 $^{+0.00}_{-0.13}$) ∇
- TAP 10-32 UNF-2B
- X .110(2.79) ∇ PERF. THD.

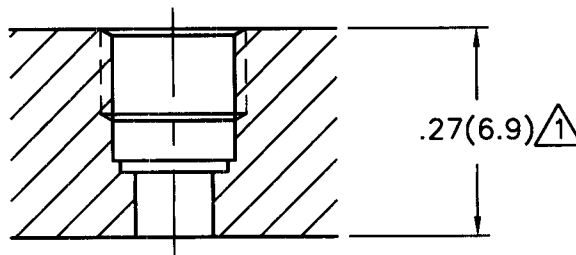

FLUSH MOUNT

- ④ RECOMMENED MOUNTING TORQUE ON .156(4.00) HEX TO BE 15 INCH LBS.(169 Ncm)
- ③ THESE DIAMETERS MUST BE CONCENTRIC TO WITHIN .001(0.03) TIR
- ② SEAL SURFACES MUST BE FLAT AND FREE OF TOOL MARKS WITH A MIN. 63√(1.6√) FINISH
- ① FOR INSTALLATIONS DEEPER THAN .27(6.9) └ ∅.250(∅6.35) TO CLEAR BODY

UNLESS SPECIFIED TOLERANCES		DRAWN	MDD	5/14/99	MFG	JRS	9/14/99	 3425 WALDEN AVE. DEPEW, NY 14043 (716) 684-0001 EMAIL: SALES@PCB.COM
DIMENSIONS IN INCHES	DIMENSIONS IN MILLIMETERS (IN PARENTHESIS)	CHK'D	Bm	9/14/99	ENGR	ACT	9-15-99	
DECIMALS XX ±.01 XXX ±.005	DECIMALS XX ±0.3 XXX ±0.13	APP'D	WSH	9/22/99	Sales	RAA	9/22/99	
ANGLES ±2 DEGREES	ANGLES ±2 DEGREES	TITLE	INSTALLATION DRAWING MODEL 105C22 PRESSURE SENSOR					CODE IDENT. NO. 52681
FILLETS AND RADII .003 - .005	FILLETS AND RADII (0.07 - 0.13)							DWG. NO. 11563
DD011 REV. B 03/13/98							SCALE: 4X	SHEET 1 OF 2

11563

PCB Piezotronics Inc. claims proprietary rights in the information disclosed hereon. Neither it nor any reproduction thereof will be disclosed to others without written consent of PCB Piezotronics Inc.

APPLICATION		
NEXT ASS'Y	USED ON	VAR

REVISIONS				
REV	DESCRIPTION	ECN	DATE	APP'D

ELECTRICAL CONNECTOR
COAXIAL 5-44 UNF-2A

④ .156(4.00) HEX

10-32 UNF-2A

MODEL 065A38 SEAL
.105(2.67) THICK
MATERIAL: BRASS
(OPTIONAL)

$.099^{+.000}_{-.001}$ (2.51 $^{+0.00}_{-0.03}$)
 $.140^{+.000}_{-.001}$ (3.57 $^{+0.00}_{-0.03}$)

.11(2.8)

.90(22.7)

.27(6.9)

$.100^{+.000}_{-.001}$ (2.54 $^{+0.00}_{-0.03}$)

MOUNTING HOLE PREPARATION:

- ϕ .140(ϕ 3.57) ③
- X .270(6.86) ▽ ②
- ϕ .159(ϕ 4.04) ③
- X .200(5.08) ▽
- TAP 10-32 UNF-2B
- X .110(2.79) ▽ PERF. THD.

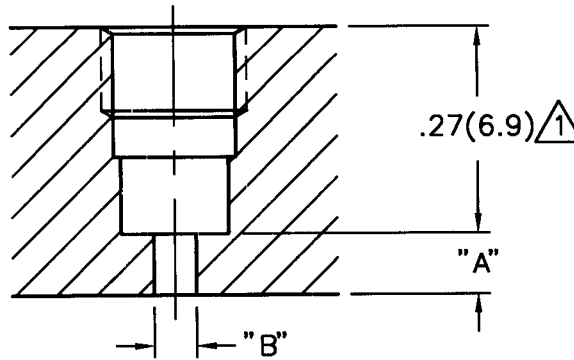

RECESS MOUNT

5.) DIMENSIONS "A" & "B" TO SUIT
USERS REQUIREMENTS

- ④ RECOMMENED MOUNTING TORQUE ON .156(4.00) HEX TO BE 15 INCH LBS.(169 Ncm)
- ③ THESE DIAMETERS MUST BE CONCENTRIC TO WITHIN .001(0.03) TIR
- ② SEAL SURFACES MUST BE FLAT AND FREE OF TOOL MARKS WITH A MIN. 63√(1.6√) FINISH
- ① FOR INSTALLATIONS DEEPER THAN .27(6.9) □ ϕ .250(ϕ 6.35) TO CLEAR BODY

UNLESS SPECIFIED TOLERANCES		DRAWN	MFG	PCB PIEZOTRONICS™		
DIMENSIONS IN INCHES	DIMENSIONS IN MILLIMETERS (IN PARENTHESIS)	MOD 9/14/99	JBS 9/14/99	3425 WALDEN AVE. DEPEW, NY 14043		
DECIMALS XX ± .01	DECIMALS XX ± 0.3	CHK'D DYM 9/14/99	ENGR AT 9-15-99	(716) 684-0001 EMAIL: SALES@PCB.COM		
XXX ± .005	XXX ± 0.13	APP'D WSH 9/22/99	S DOO RUC	CODE	DWG. NO.	
ANGLES ± 2 DEGREES	ANGLES ± 2 DEGREES	TITLE	INSTALLATION DRAWING	52681	11563	
FILLET AND RADII .003 - .005	FILLET AND RADII (0.07 - 0.13)	MODEL 105C22 PRESSURE SENSOR			SCALE: 4X	SHEET 2 OF 2
DD011 REV. B 03/13/98						