

Repair and Maintenance

PCB guarantees Total Customer Satisfaction through its “Lifetime Warranty Plus” on all Platinum Stock Products sold by PCB and through its limited warranties on all other PCB Stock, Standard and Special products. Due to the sophisticated nature of our sensors and associated instrumentation, **field servicing and repair is not recommended and, if attempted, will void the factory warranty.**

Beyond routine calibration and battery replacements where applicable, our products require no user maintenance. Clean electrical connectors, housings, and mounting surfaces with solutions and techniques that will not harm the material of construction. Observe caution when using liquids near devices that are not hermetically sealed. Such devices should only be wiped with a dampened cloth—never saturated or submerged.

In the event that equipment becomes damaged or ceases to operate, our Application Engineers are here to support your troubleshooting efforts 24 hours a day, 7 days a week. Call or email with model and serial number as well as a brief description of the problem.

Calibration

Routine calibration of sensors and associated instrumentation is necessary to maintain measurement accuracy. We recommend calibrating on an annual basis, after exposure to any extreme environmental influence, or prior to any critical test.

PCB Piezotronics is an ISO-9001 certified company whose calibration services are accredited by A2LA to ISO/IEC 17025, with full traceability to SI through N.I.S.T. In addition to our standard calibration services, we also offer specialized tests, including: sensitivity at elevated or cryogenic temperatures, phase response, extended high or low frequency response, extended range, leak testing, hydrostatic pressure testing, and others. For more information, contact your local PCB Piezotronics distributor, sales representative, or factory customer service representative.

Returning Equipment

If factory repair is required, our representatives will provide you with a Return Material Authorization (RMA) number, which we use to reference any information you have already provided and expedite the repair process. This number should be clearly marked on the outside of all returned package(s) and on any packing list(s) accompanying the shipment.

Contact Information

PCB Piezotronics, Inc.
3425 Walden Ave.
Depew, NY14043 USA
Toll-free: (800) 828-8840
24-hour SensorLine: (716) 684-0001
General inquiries: info@pcb.com
Repair inquiries: rma@pcb.com

For a complete list of distributors, global offices and sales representatives, visit our website, www.pcb.com.

Safety Considerations

This product is intended for use by qualified personnel who recognize shock hazards and are familiar with the precautions required to avoid injury. While our equipment is designed with user safety in mind, the protection provided by the equipment may be impaired if equipment is used in a manner not specified by this manual.

Discontinue use and contact our 24-Hour Sensorline if:

- Assistance is needed to safely operate equipment
- Damage is visible or suspected
- Equipment fails or malfunctions

For complete equipment ratings, refer to the enclosed specification sheet for your product.

Definition of Terms and Symbols

The following symbols may be used in this manual:



DANGER

Indicates an immediate hazardous situation, which, if not avoided, may result in death or serious injury.

**CAUTION**

Refers to hazards that could damage the instrument.

**NOTE**

Indicates tips, recommendations and important information. The notes simplify processes and contain additional information on particular operating steps.

The following symbols may be found on the equipment described in this manual:



This symbol on the unit indicates that high voltage may be present. Use standard safety precautions to avoid personal contact with this voltage.



This symbol on the unit indicates that the user should refer to the operating instructions located in the manual.



This symbol indicates safety, earth ground.



PCB工业监视和测量设备 - 中国RoHS2公布表

PCB Industrial Monitoring and Measuring Equipment - China RoHS 2 Disclosure Table

部件名称	有害物质					
	铅 (Pb)	汞 (Hg)	镉 (Cd)	六价铬 (Cr(VI))	多溴联苯 (PBB)	多溴二苯醚 (PBDE)
住房	0	0	0	0	0	0
PCB板	X	0	0	0	0	0
电气连接器	0	0	0	0	0	0
压电晶体	X	0	0	0	0	0
环氧	0	0	0	0	0	0
铁氟龙	0	0	0	0	0	0
电子	0	0	0	0	0	0
厚膜基板	0	0	X	0	0	0
电线	0	0	0	0	0	0
电缆	X	0	0	0	0	0
塑料	0	0	0	0	0	0
焊接	X	0	0	0	0	0
铜合金/黄铜	X	0	0	0	0	0
本表格依据 SJ/T 11364 的规定编制。						
0：表示该有害物质在该部件所有均质材料中的含量均在 GB/T 26572 规定的限量要求以下。						
X：表示该有害物质至少在该部件的某一均质材料中的含量超出 GB/T 26572 规定的限量要求。						
铅是欧洲RoHS指令2011/65/ EU附件三和附件四目前由于允许的豁免。						

CHINA RoHS COMPLIANCE

Component Name	Hazardous Substances					
	Lead (Pb)	Mercury (Hg)	Cadmium (Cd)	Chromium VI Compounds (Cr(VI))	Polybrominated Biphenyls (PBB)	Polybrominated Diphenyl Ethers (PBDE)
Housing	O	O	O	O	O	O
PCB Board	X	O	O	O	O	O
Electrical Connectors	O	O	O	O	O	O
Piezoelectric Crystals	X	O	O	O	O	O
Epoxy	O	O	O	O	O	O
Teflon	O	O	O	O	O	O
Electronics	O	O	O	O	O	O
Thick Film Substrate	O	O	X	O	O	O
Wires	O	O	O	O	O	O
Cables	X	O	O	O	O	O
Plastic	O	O	O	O	O	O
Solder	X	O	O	O	O	O
Copper Alloy/Brass	X	O	O	O	O	O

This table is prepared in accordance with the provisions of SJ/T 11364.

O: Indicates that said hazardous substance contained in all of the homogeneous materials for this part is below the limit requirement of GB/T 26572.

X: Indicates that said hazardous substance contained in at least one of the homogeneous materials for this part is above the limit requirement of GB/T 26572.

Lead is present due to allowed exemption in Annex III or Annex IV of the European RoHS Directive 2011/65/EU.

**OPERATING GUIDE
DYNAMIC (CRYOGENIC)
ICP® PRESSURE SENSORS
MODELS 102B10, B11, B13, B14**

1.0 DESCRIPTION

This sensor series consists of a Model 112A quartz pressure element coupled to a special MOSFET amplifier circuit to permit operation at cryogenic temperatures.

Cryogenic sensors use special electronics that have some characteristics differing from standard designs.

Polarity of the output signal is positive-going for increasing pressure.

2.0 INSTALLATION

Refer to installation drawing for mounting hole preparation. The outer housing of the thread adaptor is ground isolated from the sensing element.

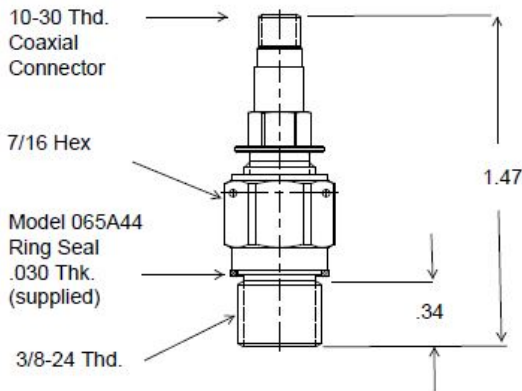

Series 102B10: Cryogenic Pressure Sensor

Prepare mounting ports in accordance with the installation drawing for the specific model, paying particular attention to sealing surfaces. These surfaces must be smooth and free from chatter marks, nicks and other irregularities which could prevent a pressure-tight seal.

Seals are provided with each sensor and should always be used. Extra seals for all standard models are in stock at the factory. It is recommended to replace the seals every time the sensor is re-installed.

Although these low-impedance sensors are not affected by moisture, in extreme environments such as cryogenic, it is advisable to protect cable connections with shrink tubing. Low-noise cable

(003A) is not necessary. Model 070A09 solder connector adaptor permits the use of ordinary two-wire cable.

3.0 OPERATION

These sensors are operated like standard ICP® sensors.

For general laboratory-type use, either Model 480C02 battery-powered signal conditioner or Model 482A06 line-powered signal conditioner is recommended for use with Cryogenic Sensors. Both Models provide 2 mA constant current to power the sensor electronics.

Other standard signal conditioners Series 481A, 482A, and 483A may also be used, provided the current is adjusted to 2 mA. All above Models include a bias de-coupling capacitor in series with the output connector.

For telemetry applications, Model 495A signal conditioner provides band pass filtering, adjustable gain, bias and limiting.

4.0 CALIBRATION

Because of the relatively short time constants of these sensors (see specification sheet at the front of this manual), only dynamic calibration methods can be used.

5.0 MAINTENANCE

Because of the miniature size and built-in electronics of these units, field maintenance is not recommended.

**OPERATING GUIDE
DYNAMIC (CRYOGENIC)
ICP[®] PRESSURE SENSORS
MODELS 102B10, B11, B13, B14**

6.0 CAUTION

The FET amplifier used in these sensors is a special low-noise device with gate breakdown voltage of 125 volts.

This voltage rating can be exceeded by either imposing a high-pressure step or a fast-rising pressure ramp to the diaphragm in excess of the rating for the sensor.



Slowly applied or released static pressure levels, within the mechanical capability of the sensor, are not dangerous since the charge generated by the quartz element has time to leak off through the FET bias resistor.

It is important to note that the following two pressure ratings are involved:

1. Maximum total pressure (mechanical consideration).
2. Maximum step pressure (electrical consideration).

NOTE: To avoid damage to the sensor, limit pressure application to maximum values on specification sheet at the front of this manual.

The maximum step pressure may be exceeded up to the maximum total pressure level provided the total pressure (rise or fall) takes place.

Model Number 102B11	ICP® PRESSURE SENSOR			Revision: C ECN #: 51804									
Performance Measurement Range(for ±5V output) Useful Overrange(for ± 10V output) Sensitivity Maximum Pressure(step) Maximum Pressure(Total) Resolution Resonant Frequency Rise Time(Reflected) Low Frequency Response(- 5 %) Non-Linearity Environmental Acceleration Sensitivity Temperature Range(Operating) Temperature Coefficient of Sensitivity Maximum Shock Electrical Output Polarity(Positive Pressure) Discharge Time Constant(at room temp) Excitation Voltage Constant Current Excitation Output Impedance Output Bias Voltage Physical Sensing Element Housing Material Thread Adaptor Material Diaphragm Sealing Electrical Connector Weight	ENGLISH 1 kpsi 2,000 psi 5.0 mV/psi 10,000 psi 15 kpsi 20 mpsi ≥ 250 kHz ≤ 2.0 μ sec 0.25 Hz ≤ 1.0 % FS ≤ 0.002 psi/g -320 to +212 °F ≤ 0.06 %/°F 20,000 g pk Positive ≥ 2.0 sec 20 to 30 VDC 2 to 20 mA < 100 Ohm 9 to 13 VDC Quartz 304L/316L Stainless Steel 316L Stainless Steel 316L Stainless Steel Welded Hermetic 10-32 Coaxial Jack .388 oz	SI 6,895 kPa 13,790 kPa [1] 0.725 mV/kPa 69,000 kPa 103,425 kPa [2] 0.138 kPa ≥ 250 kHz ≤ 2.0 μ sec 0.25 Hz ≤ 1.0 % FS [3] ≤ 0.0014 kPa/(m/s ²) -196 to +100 °C ≤ 0.108 %/°C 196,133 m/s ² pk Positive ≥ 2.0 sec 20 to 30 VDC 2 to 20 mA < 100 Ohm 9 to 13 VDC Quartz 304L/316L Stainless Steel 316L Stainless Steel 316L Stainless Steel Welded Hermetic 10-32 Coaxial Jack 11.00 gm	OPTIONAL VERSIONS Optional versions have identical specifications and accessories as listed for the standard model except where noted below. More than one option may be used. M - Metric Mount Optional Accessory: Model 065A34 Seal ring 0.435" OD x 0.397" ID x 0.030" Cu (3)										
NOTES: [1]Excitation voltage >=28 volts required. [2]Due to high sensitivity, the static pressure should be applied and removed very slowly. Rate should prevent more than 10 Volt change in output until Output Bias Voltage returns to normal (approximately 15 times discharge time constant). [3]Zero-based, least-squares, straight line method. [4]See PCB Declaration of Conformance PS023 for details.													
SUPPLIED ACCESSORIES: Model 065A44 Seal ring 0.435" OD x 0.377" ID x 0.030" thk Cu (3)													
<table border="1"> <tr> <td>Entered: RB</td> <td>Engineer: MP</td> <td>Sales: MV</td> <td>Approved: RPF</td> <td>Spec Number:</td> </tr> <tr> <td>Date: 06/18/2021</td> <td>Date: 06/18/2021</td> <td>Date: 06/18/2021</td> <td>Date: 06/18/2021</td> <td>70581</td> </tr> </table>				Entered: RB	Engineer: MP	Sales: MV	Approved: RPF	Spec Number:	Date: 06/18/2021	Date: 06/18/2021	Date: 06/18/2021	Date: 06/18/2021	70581
Entered: RB	Engineer: MP	Sales: MV	Approved: RPF	Spec Number:									
Date: 06/18/2021	Date: 06/18/2021	Date: 06/18/2021	Date: 06/18/2021	70581									
<div style="display: flex; justify-content: space-between;"> <div data-bbox="193 1128 310 1193">  </div> <div data-bbox="1136 1369 1686 1442">  <p>Phone: 716-684-0001 Fax: 716-684-0987 E-Mail: info@pcb.com</p> </div> </div> <p>All specifications are at room temperature unless otherwise specified. In the interest of constant product improvement, we reserve the right to change specifications without notice. ICP® is a registered trademark of PCB Piezotronics, Inc.</p>													

PCB Piezotronics Inc. claims proprietary rights in the information disclosed hereon. Neither it nor any reproduction thereof will be disclosed to others without the written consent of PCB Piezotronics Inc.

70414

REVISIONS		
REV	DESCRIPTION	DIN
A	UPDATED TORQUE NOTE	52229

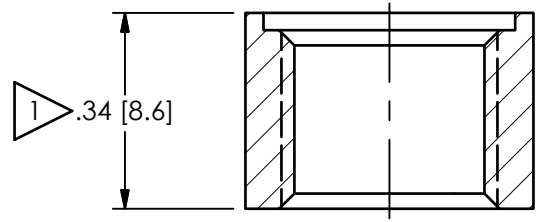
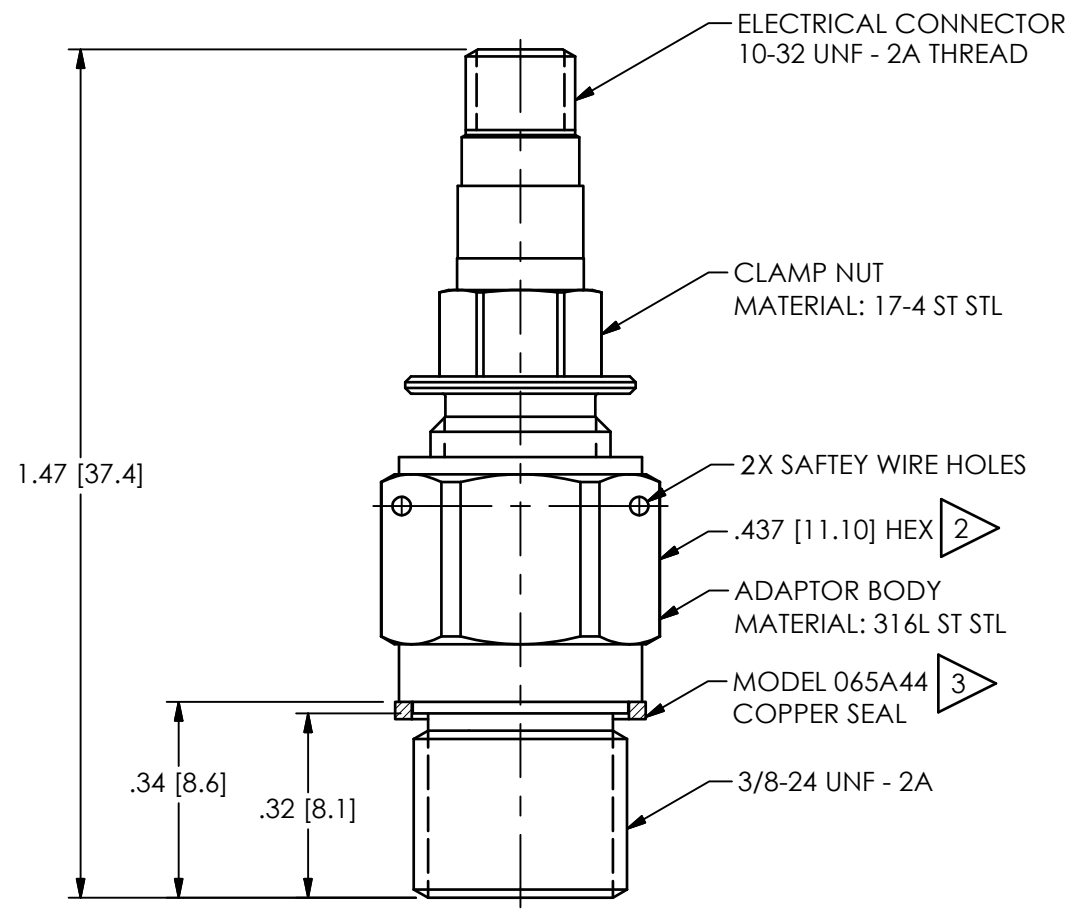
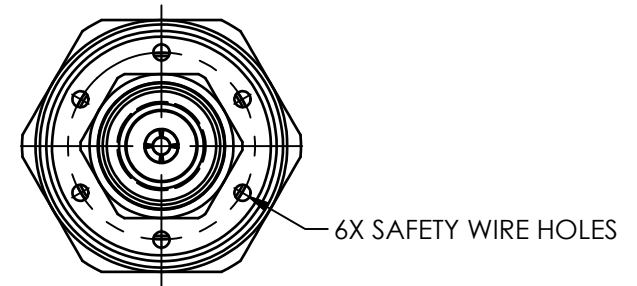

MOUNTING HOLE PREPARATION:
 \varnothing .332 [8.43] THRU
 \llcorner \varnothing .437 [11.10] ∇ .030 [.76]
 3/8-24 UNF-2B THRU

- 3 MODEL 065M29 ST STL SEAL AVAILABLE
- 2 MOUNTING TORQUE ON 7/16 HEX: 5 - 8 FT LBS [6.78 - 10.85 Nm] WITHOUT THREAD LUBRICANT
- 1 ABOVE INSTALLATION SHOWN FOR WALL THICKNESS OF .34 [8.6] THICK, \llcorner THICKER
 WALLS \varnothing .75 [19.0] TO CLEAR .437 [11.10] HEX AND ALLOW FOR SOCKET WRENCH

UNLESS OTHERWISE SPECIFIED TOLERANCES ARE:		DRAWN		CHECKED		ENGINEER		 PCB PIEZOTRONICS AN AMPHENOL COMPANY 3425 WALDEN AVE. DEPEW, NY 14043 (716) 684-0001 E-MAIL: sales@pcb.com
DIMENSIONS IN INCHES	DIMENSIONS IN MILLIMETERS [IN BRACKETS]	JJF	10/27/21	JJF	10/27/21	MJP	10/27/21	
DECIMALS XX \pm .01 XXX \pm .005 ANGLES \pm 2 DEGREES	DECIMALS X \pm 0.3 XX \pm 0.13 ANGLES \pm 2 DEGREES	TITLE INSTALLATION DRAWING CRYOGENIC GROUND ISOLATED ICP® PRESSURE SENSOR						DWG. NO. 70414
CABLE TOLERANCES IN ENGLISH 1' \leq LENGTH < 1' = +1' / - 0 1' \leq LENGTH < 5' = +2' / - 0 5' \leq LENGTH < 100' = +6' / - 0 100' \leq LENGTH = +1' / - 0	CABLE TOLERANCES IN METRIC 2.54cm \leq LENGTH < 30.5cm = +2.54cm / - 0 30.5cm \leq LENGTH < 1.5m = +5.1cm / - 0 1.5m \leq LENGTH < 30.5m = +15.2cm / - 0 30.5m \leq LENGTH = +30.5cm / - 0							SCALE: 3X
FILLETS AND RADII .003 - .005	FILLETS AND RADII 0.07 - 0.13							