



**Model 054220-01224**

**Strain Gage Load Cell**

**Installation and Operating Manual**

**For assistance with the operation of this product, contact:**

**PCB Load & Torque, Inc.  
Toll-free: 866-684-7107  
24-hour SensorLine™: 716-684-0001  
Fax: 248-888-8266  
E-mail: [LTInfo@pcbloadtorque.com](mailto:LTInfo@pcbloadtorque.com)  
Web: [www.pcbLoadTorque.com](http://www.pcbLoadTorque.com)**



**The information contained in this document supersedes all similar information that may be found elsewhere in this manual.**

**Total Customer Satisfaction** – PCB Piezotronics guarantees Total Customer Satisfaction. If, at any time, for any reason, you are not completely satisfied with any PCB product, PCB will repair, replace, or exchange it at no charge. You may also choose to have your purchase price refunded in lieu of the repair, replacement, or exchange of the product.

**Service** – Due to the sophisticated nature of the sensors and associated instrumentation provided by PCB Piezotronics, user servicing or repair is not recommended and, if attempted, may void the factory warranty. Routine maintenance, such as the cleaning of electrical connectors, housings, and mounting surfaces with solutions and techniques that will not harm the physical material of construction, is acceptable. Caution should be observed to insure that liquids are not permitted to migrate into devices that are not hermetically sealed. Such devices should only be wiped with a dampened cloth and never submerged or have liquids poured upon them.

**Repair** – In the event that equipment becomes damaged or ceases to operate, arrangements should be made to return the equipment to PCB Piezotronics for repair. User servicing or repair is not recommended and, if attempted, may void the factory warranty.

**Calibration** – Routine calibration of sensors and associated instrumentation is

recommended as this helps build confidence in measurement accuracy and acquired data. Equipment calibration cycles are typically established by the users own quality regimen. When in doubt about a calibration cycle, a good “rule of thumb” is to recalibrate on an annual basis. It is also good practice to recalibrate after exposure to any severe temperature extreme, shock, load, or other environmental influence, or prior to any critical test.

PCB Piezotronics maintains an ISO-9001 certified metrology laboratory and offers calibration services, which are accredited by A2LA to ISO/IEC 17025, with full traceability to N.I.S.T. In addition to the normally supplied calibration, special testing is also available, such as: sensitivity at elevated or cryogenic temperatures, phase response, extended high or low frequency response, extended range, leak testing, hydrostatic pressure testing, and others. For information on standard recalibration services or special testing, contact your local PCB Piezotronics distributor, sales representative, or factory customer service representative.

**Returning Equipment** – *Following these procedures will insure that your returned materials are handled in the most expedient manner.* Before returning any equipment to PCB Piezotronics, contact your local distributor, sales representative, or factory customer service representative to obtain a Return

Materials Authorization (RMA) Number. This RMA number should be clearly marked on the outside of all package(s) and on the packing list(s) accompanying the shipment. A detailed account of the nature of the problem(s) being experienced with the equipment should also be included inside the package(s) containing any returned materials.

A Purchase Order, included with the returned materials, will expedite the turn-around of serviced equipment. It is recommended to include authorization on the Purchase Order for PCB to proceed with any repairs, as long as they do not exceed 50% of the replacement cost of the returned item(s). PCB will provide a price quotation or replacement recommendation for any item whose repair costs would exceed 50% of replacement cost, or any item that is not economically feasible to repair. For routine calibration services, the Purchase Order should include authorization to proceed and return at current pricing, which can be obtained from a factory customer service representative.

**Warranty** – All equipment and repair services provided by PCB Piezotronics, Inc. are covered by a limited warranty against defective material and workmanship for a period of one year from date of original purchase. Contact

PCB for a complete statement of our warranty. Expendable items, such as batteries and mounting hardware, are not covered by warranty. Mechanical damage to equipment due to improper use is not covered by warranty. Electronic circuitry failure caused by the introduction of unregulated or improper excitation power or electrostatic discharge is not covered by warranty.

**Contact Information** – International customers should direct all inquiries to their local distributor or sales office. A complete list of distributors and offices can be found at [www.pcb.com](http://www.pcb.com). Customers within the United States may contact their local sales representative or a factory customer service representative. A complete list of sales representatives can be found at [www.pcb.com](http://www.pcb.com). Toll-free telephone numbers for a factory customer service representative, in the division responsible for this product, can be found on the title page at the front of this manual. Our ship to address and general contact numbers are:

PCB Piezotronics, Inc.  
3425 Walden Ave.  
Depew, NY 14043 USA  
Toll-free: (800) 828-8840  
24-hour SensorLine<sup>SM</sup>: (716) 684-0001  
Website: [www.pcb.com](http://www.pcb.com)  
E-mail: [info@pcb.com](mailto:info@pcb.com)



# Fastener Force Washer Transducer Installation and Operating Manual



**For assistance with the operation of this product, contact:  
RS Technologies, Division of PCB Load & Torque, Inc.  
Toll-Free in USA: 888-684-2894  
24-hour SensorLine<sup>SM</sup>: 716-684-0001  
Fax: 248-888-8266  
E-mail: [rsinfo@pcbloadtorque.com](mailto:rsinfo@pcbloadtorque.com)**

## 1.0 INTRODUCTION

The Fastener Force Washer Transducers manufactured by RS Technologies Division of PCB Load & Torque, Inc., are designed to measure the clamp load generated when a threaded fastener is tightened. The rated capacity of the force washer for your particular model is indicated on the attached outline drawing and specification sheet. These force washers utilize strain gages configured into a Wheatstone Bridge Circuit to produce the primary sensing elements. The four-arm Wheatstone Bridge configuration is shown below in **Figure 1**.

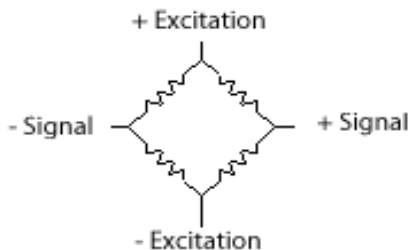

**Figure 1 - Wheatstone Bridge Circuit**

The force washer follows the wiring code shown in Figure 2 below. Most Fastener Force Washer Transducers are provided with a single cable with pigtail leads with the color code shown below. If provided from the factory with a connector, the wiring code may differ from the illustration.

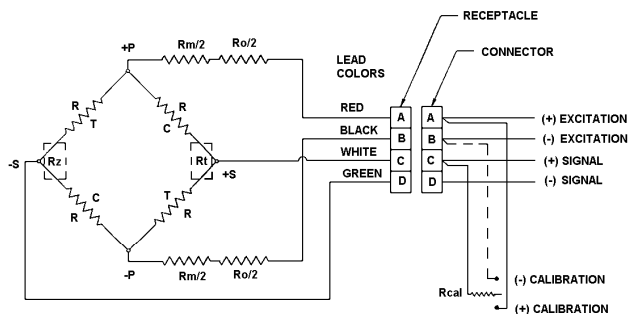

- NOTES:
1. R Gage Resistance  
Rm Modulus Resistor  
Ro Output Scaling Resistor  
Rt Temperature Compensation Resistor  
Rz Zero Balance Resistor
  2. Ro and Rm may be omitted.
  3. Colors denote wiring connections for captive cable sensors.
  4. (-) Calibration applies only to bi-directional sensors.

**Figure 2 – Transducer Wiring Code**

The strain gages are bonded to the force washer's structure. Typically, a regulated DC or AC excitation is applied between the (+) and (-) excitation leads of the bridge. When a load is applied to the force washer, the Wheatstone Bridge becomes unbalanced, producing an output voltage between the (+) and (-) signal leads, which is proportional to the applied load. The magnitude of the output voltage corresponds to the deformation of the force washer and therefore the applied load. This configuration allows for temperature and pressure

compensation, as well as cancellation of signals caused by forces not directly applied to the axis of the applied load. Output is typically expressed in units of millivolt per volt of excitation.

The force washer requires a dedicated signal conditioner to provide regulated DC excitation voltage. Optional signal conditioners are available from RS Technologies. Depending on which model is used, the signal conditioner may have analog voltage output, current output, or digital output. Digital display signal conditioners are also available.

A careful structural analysis has been done to isolate the forces and moments, which results in a reduction of cross-talk sensitivities. A variety of configurations and combination of force and moment measurements are available.

### Axis Definition

RS Technologies Division of PCB Load & Torque, Inc. products comply with the Axis and Sense Definitions of NAS-938 (National Aerospace Standard-Machine Axis and Motion) nomenclature. These axes are defined in terms of a "Right Handed" orthogonal coordinate system as show below.

Because of their specific application, all fastener force washer transducers provide a (+) output signal when placed in compression, such as when the threaded fastener is tightened.

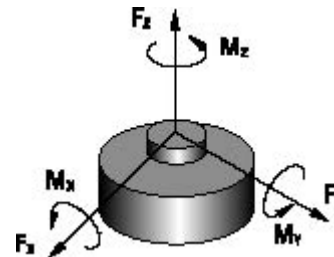

**Figure 3 - Generic Axis and Sense Nomenclature for PCB® Load Cells**

## 2.0 SAFETY INFORMATION

Failure of the force washer structure may cause personal injury and/or equipment damage. To prevent structure failure, review the extraneous load limits listed on the force washer specification sheet supplied with this manual.

Loads must be limited to 100% of the measurement axis load combined with 200% of any one of the extraneous loads. To determine an acceptable level of extraneous loads that prevents output signal degradation, review the extraneous load limits and note on the specification sheet.

### 3.0 MECHANICAL INSTALLATION

Refer to the outline drawing supplied with this manual for specific outline dimensions and installation details for your particular model. The specification sheet is also included to provide details of the sensor's characteristic properties.

It is important that the surface to which each force washer is mounted be as clean and perfectly flat as possible to avoid spot loading, which could affect sensor sensitivity and result in erroneous data. Ensure that the sensor is correctly aligned and oriented, and that it is mounted with proper hardware and properly tightened.

Each fastener force washer transducer is provided with a matching pair of hardened ground washers. The ID of one of the washers is beveled and this washer is placed with the bevel facing the underside of the head of the fastener on top of the force washer as shown in Figure 4. The other washer is placed underneath the bottom surface of the force washer transducer.

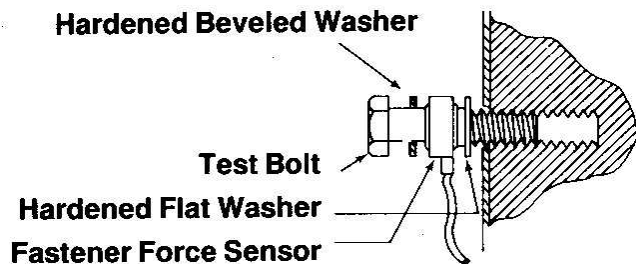

Figure 4 – Force Washer Installation

**IMPORTANT NOTE:** Fastener Force Washer Transducers are not designed for use as high-accuracy clamp force measurement devices. They are priced and intended for use where only an estimate of clamp force is required. They are sensitive to off-center and angular loading conditions that may adversely impact measurement accuracy.

### 4.0 ELECTRICAL INSTALLATION

The fastener force washer transducers come with integral cables and pigtail leads. The type of connector for your force washer will depend on what is required to connect to the signal conditioner/data collector. For proper electrical connections, refer to the wiring drawing for the signal conditioner used, and the outline drawing for the force washer. Construct any necessary interconnecting cables from high-quality shielded instrumentation cable.

Attach the output end of the interconnecting cable to the signal conditioner/data collector. For installation in dirty, humid, or rugged environments, it is suggested that the connection be shielded against dust or moisture with shrink tubing or other protective material. Because of its typical use the force washer

may rotate with the fastener while it is being tightened, so be sure to provide some slack in the cable in the event that the force washer turns during the test. Adequate strain relieving the cable/sensor connection may prolong cable life. Mounting cables to a test structure with clamps, tape, or adhesives helps to minimize cable whip. Refer to **Figure 5** for a simple example of a sensor installation with a securely fastened cable. The cabling for your force washer may require more robust strain relief.

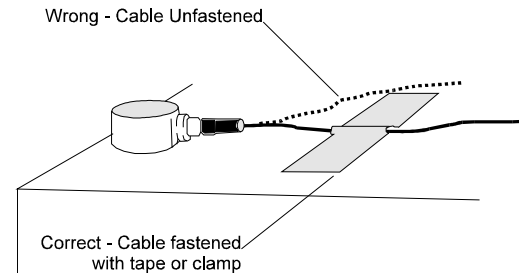

Figure 5 – Simple Cable Strain Relief

### 5.0 POLARITY

Every fastener force washer transducer produces a (+) output signal when placed in compression.

### 6.0 SHUNT CALIBRATION

Shunt calibration is the known, electrical unbalancing of a strain gage bridge by means of a fixed resistor that is placed, or “shunted”, across one leg of the bridge. The Wheatstone Bridge utilized by RS Technologies force washers are typically calibrated using the shunt calibration technique. The shunt calibration resistor impedance and the associated shunt calibration value in engineering units are provided on the Calibration Certificate.

Shunt calibration is a method of periodically checking the gain or span of a signal conditioner, which is used in conjunction with a strain gage based transducer, without exposing the transducer to known, traceable, physical input values. If required, adjustments can then be made to the signal conditioner to ensure accurate measurement results.

The strain gage bridge is “in balance” when the mechanical structure is unloaded and unstressed. As the structure is loaded or stressed, the Wheatstone Bridge becomes unbalanced, resulting in an output signal that is proportional to the applied load.

Shunt calibration simulates the mechanical input to a transducer by unbalancing the bridge with a fixed resistor placed across, or in parallel with, one leg of the bridge. For compression shunt calibration, or +CAL, the shunt resistor ( $R_{sc}$ ) is shunted across the +Excitation and +Signal leg of the

bridge. See **Figure 2** for shunt resistor locations in the Wheatstone Bridge circuit.

Shunt calibration is accepted throughout the industry as a means of periodic field calibration of a signal conditioner and transducer between calibrations of known, applied, traceable, mechanical input values. Consequently, most all strain gage transducer manufacturers collect and supply shunt calibration data, along with a shunt calibration resistor, as a standard feature.

### Shunt Calibration Procedure

The following procedure is provided as a basic outline of how shunt calibration is accomplished. The actual shunt calibration routine will depend on the instrument that you will use to read the clamp load.

1. Connect the transducer to an appropriate strain gage signal conditioner and allow adequate time for the system to stabilize. 2 to 5 minutes is recommended.
2. With no load on the transducer. Adjust the signal conditioner's zero controls for each bridge to read zero (0).
3. Shunt the calibration resistor between the desired excitation and signal leads of the Wheatstone Bridge, as described in Section 6.0.
4. Adjust the signal conditioner's gain or span controls as required to obtain an electrical output signal and/or numeric display that represents the simulated calibration load as indicated on the calibration certificate.
5. Remove the shunt resistor and adjust the zero if necessary.
6. If a significant zero adjustment is required, repeat Steps 3-5.
7. Repeat the process for the other axis.

## 7.0 OPERATION

### Typical Force Washer Configurations

Fastener force washer transducers can be used in several configurations. Some may be used with a single data collector or readout instrument to measure the clamp load generated when the threaded fastener is tightened. Others may be used with a multiple channel data recorder and a torque or torque angle transducer to determine torque-angle-tension data. Strain gage signal conditioners and cable assemblies are available from RS Technologies Division of PCB Load & Torque, Inc.

### Operation with a Signal Conditioner

The signal conditioner span and zero must be set before the force washer system can be used. The span can be set using the shunt calibration value as described in Section 6.0. Refer to the signal conditioner instruction manual for additional set-up information.

## 8.0 TROUBLESHOOTING

Refer to the guidelines below if problems arise.

### No output

- ✓No power
- ✓Loose or dirty connections
- ✓Open circuit or shorts
- ✓Faulty or improper wiring
- ✓No load applied

### Erratic or Improper Readings

- ✓Excitation voltage drift
- ✓Electrical noise
- ✓Loose fixturing
- ✓Open circuit or shorts
- ✓Improper load applied
- ✓Cable too long

### Blinking Display

- ✓Overload condition
- ✓Open circuit

### Zero Balance

- ✓Load applied to sensor
- ✓Overloaded or side-loaded sensor
- ✓Open circuit
- ✓Improper electrical connections

### Zero Shift

- ✓Fixture preload
- ✓Faulty or improper wiring
- ✓Improper tare

### Zero Drift

- ✓Unconditioned power supply
- ✓Circuit opens or shorts
- ✓Loose wiring
- ✓RFI/EMI interface
- ✓Temperature change

### Damaged or Deformed Equipment

- ✓Improper use

Often overlooked by the customer is the error due to the presence of non-measured forces and bending moments. Even though each axis of a bi-axial sensor is designed and built to withstand these non-measured forces and bending moments (extraneous loads), the errors due to them are present. Crosstalk data is provided to indicate the influence of the measured axes on each other. However, if extraneous un-measured loads are present, the errors due to them should be considered when troubleshooting operational problems.

## 9.0 ERROR ANALYSIS

RS Technologies Division of PCB Load & Torque, Inc. typically supplies accuracy information on its products in the form of individual errors (see the attached specification sheet). For Fastener Force Washer Transducers they are Non-Linearity, Hysteresis, and Non-Repeatability. The actual performance of you force washer will be noted on the Calibration Certificate provided by RS Technologies.

The customer can combine these individual errors through the root sum squared method to establish the maximum possible error for the measurement or just examine the applicable individual error.

If the temperature remains stable during the test, temperature related errors may be ignored. If the sensor is used for increasing load measurement only, ignore the Hysteresis error. If the load measurement is near the full capacity, the linearity error can be ignored. If the capability exists to correct the data through linearization-fit or a look-up-table, the error in the measurement can be minimized. A sophisticated user can get rid of all the errors except for the non-repeatability error in the measurement.

## 10.0 MAINTENANCE

Routine maintenance, such as cleaning of electrical connectors, housings, and mounting surfaces with solutions and techniques that will not harm the physical material of construction is acceptable. Caution should be observed to ensure that liquids are not permitted to migrate into devices that are not hermetically sealed. Such devices should only be wiped with a damp cloth and never submerged or have liquids poured on them.

###



*MANUAL NUMBER: 47111*  
*MANUAL REVISION: A*  
*ECN NUMBER: 33512*

Model Number <b>054220-01224</b>	<b>STRAIN GAGE LOAD CELL</b>			Revision: A ECN #: 37515	
<b>Performance</b>	<b>ENGLISH</b>	<b>SI</b>		<b>OPTIONAL VERSIONS</b>	
Measurement Range(Full Scale Capacity)	49,458 lb	220 kN	[1]	Optional versions have identical specifications and accessories as listed for the standard model except where noted below. More than one option may be used.	
Sensitivity(output at rated capacity)	1.50 mV/V	1.50 mV/V	[1][4]		
Non-Linearity	± 5 % FS	± 5 % FS	[4]		
Hysteresis	± 5 % FS	± 5 % FS	[4]		
Non-Repeatability	± 2 % FS	± 2 % FS	[4]		
Resonant Frequency	10 kHz	10 kHz			
<b>Environmental</b>				<b>NOTES:</b>	
Overload Limit	74,187 lb	330 kN		[1] Nominal.	
Temperature Range(Operating)	0 to +200 ˚F	-18 to +93 ˚C		[2] Calibrated at 10 VDC, usable 5 to 20 VDC or VAC RMS.	
Temperature Range(Compensated)	N/A ˚F	N/A ˚C		[3] Over compensated operating temperature range.	
Temperature Effect on Output(Maximum)	± 0.02 %Reading/˚F	± 0.036 %Reading/˚C	[3]	[4] FS - Full Scale.	
Temperature Effect on Zero Balance(Maximum)	± 0.02 %FS/˚F	± 0.036 %FS/˚C	[4]		
<b>Electrical</b>					
Bridge Resistance	350 ohm	350 ohm	[1]		
Excitation Voltage(Recommended)	10 VDC	10 VDC	[2]		
Output Polarity(Compression)	Positive	Positive			
<b>Physical</b>					
Size (Diameter x Height)	1.62 in x 0.595 in	41.1 mm x 15.1 mm			
Fastener Size	0.787 in	20 mm			
Through Hole Diameter	0.794 in	20.16 mm			
Sensing Element	Strain Gage	Strain Gage			
Electrical Connector	pigtail ends	pigtail ends			
Electrical Connection Position	Side	Side			
<p><i>All specifications are at room temperature unless otherwise specified.</i></p> <p><i>In the interest of constant product improvement, we reserve the right to change specifications without notice.</i></p> <p>ICP® is a registered trademark of PCB Group, Inc.</p>					
Entered: DMW		Engineer: JSD	Sales: JC	Approved: GLB	Spec Number:
Date: 11/7/2011		Date: 11/7/2011	Date: 11/7/2011	Date: 11/7/2011	<b>47155</b>
			<b>PCB Load &amp; Torque, Inc.</b> <b>24350 Indoplex Circle</b> <b>Farmington Hills, MI 48335</b> <b>UNITED STATES</b> <b>Phone: 866-684-7107</b> <b>Fax: 716-684-0987</b> <b>E-Mail: <a href="mailto:Itinfo@pcbloadtorque.com">Itinfo@pcbloadtorque.com</a></b> <b>Web site: <a href="http://www.pcbloadtorque.com">http://www.pcbloadtorque.com</a></b>		