

22493

PCB Piezotronics Inc. claims proprietary rights in the information disclosed hereon. Neither it nor any reproduction thereof will be disclosed to others without the written consent of PCB Piezotronics Inc.

| REVISIONS | | |
|-----------|--|-------|
| REV | DESCRIPTION | DIN |
| B | MAKE MODEL NUMBER MORE GENERIC & UPDATE DIMENSIONS | 35661 |

ELECTRICAL CONNECTOR
10-32 UNF-2A

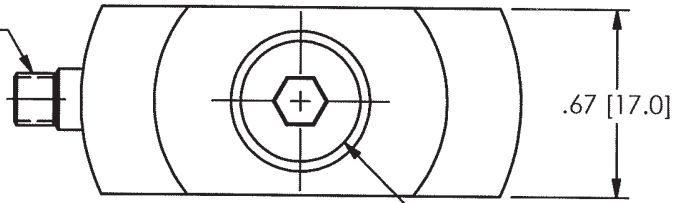

M6 X 1.00-6g X .87 [22.0] LONG
FLAT HEAD HEX SCREW
MODEL M081A100

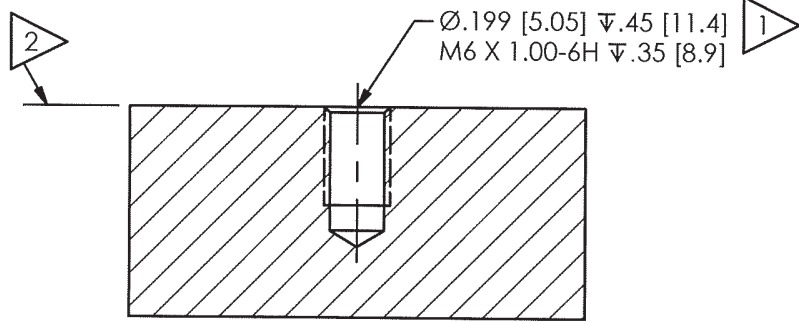
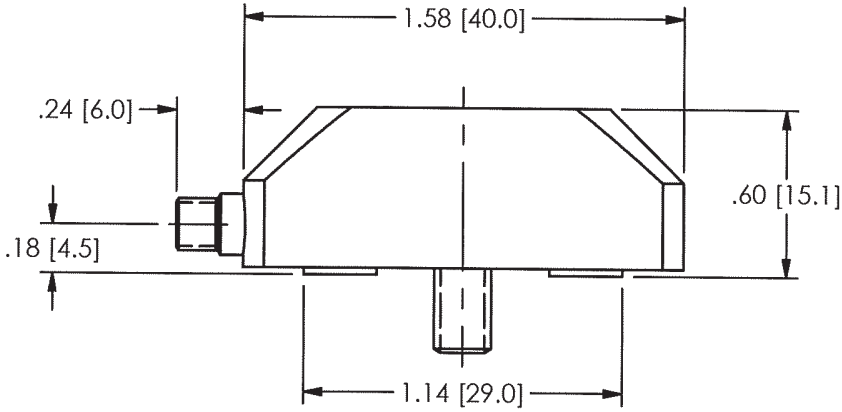

2 MOUNTING SURFACE MUST BE FLAT TO WITHIN .001 [.03] WITH AT LEAST A 125 [3.2] FINISH.

1 DRILL PERPENDICULAR TO MOUNTING SURFACE TO WITHIN 1°.

| | | | | | |
|--|---|--|---------|------------|--|
| UNLESS OTHERWISE SPECIFIED TOLERANCES ARE: | | DRAWN | CHECKED | ENGINEER | 3425 WALDEN AVE. DEPEW, NY 14043 (716) 684-0001 E-MAIL: sales@pcb.com |
| DIMENSIONS IN INCHES | DIMENSIONS IN MILLIMETERS [IN BRACKETS] | MDF 5/6/11 | ECB Sg4 | JDK 5/6/11 | |
| DECIMALS XX ±.01 XXX ±.005 | DECIMALS X ±0.3 XX ±0.13 | TITLE | | | |
| ANGLES ± 2 DEGREES | ANGLES ± 2 DEGREES | INSTALLATION DRAWING MODEL 240XXX SERIES STRAIN SENSOR | | | CODE IDENT. NO. 52681 |
| FILLETS AND RADII .003 - .005 | FILLETS AND RADII 0.07 - 0.13 | | | | DWG. NO. 22493 |
| | | | | | SCALE: 1.5X SHEET 1 OF 1 |