

PCB Piezotronics Inc. claims proprietary rights in the information disclosed hereon. Neither it nor any reproduction thereof will be disclosed to others without the written consent of PCB Piezotronics Inc.

12951

REVISIONS		
REV	DESCRIPTION	DIN
B	UPDATED THE THREADS TO 5/8-24 UNEF-2A	42431

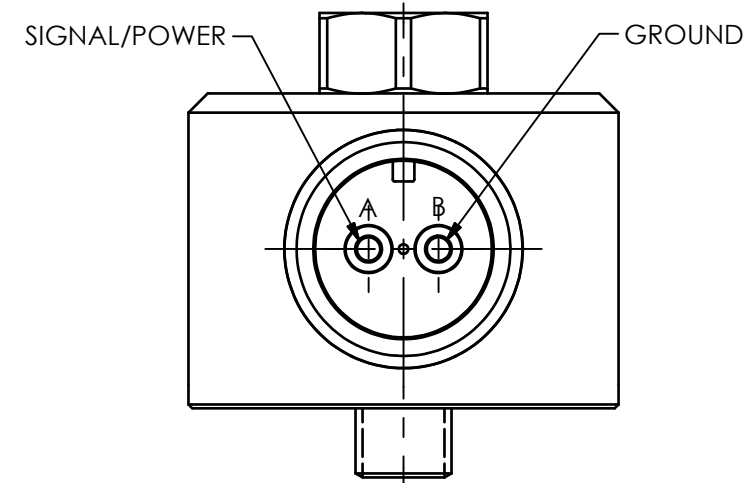
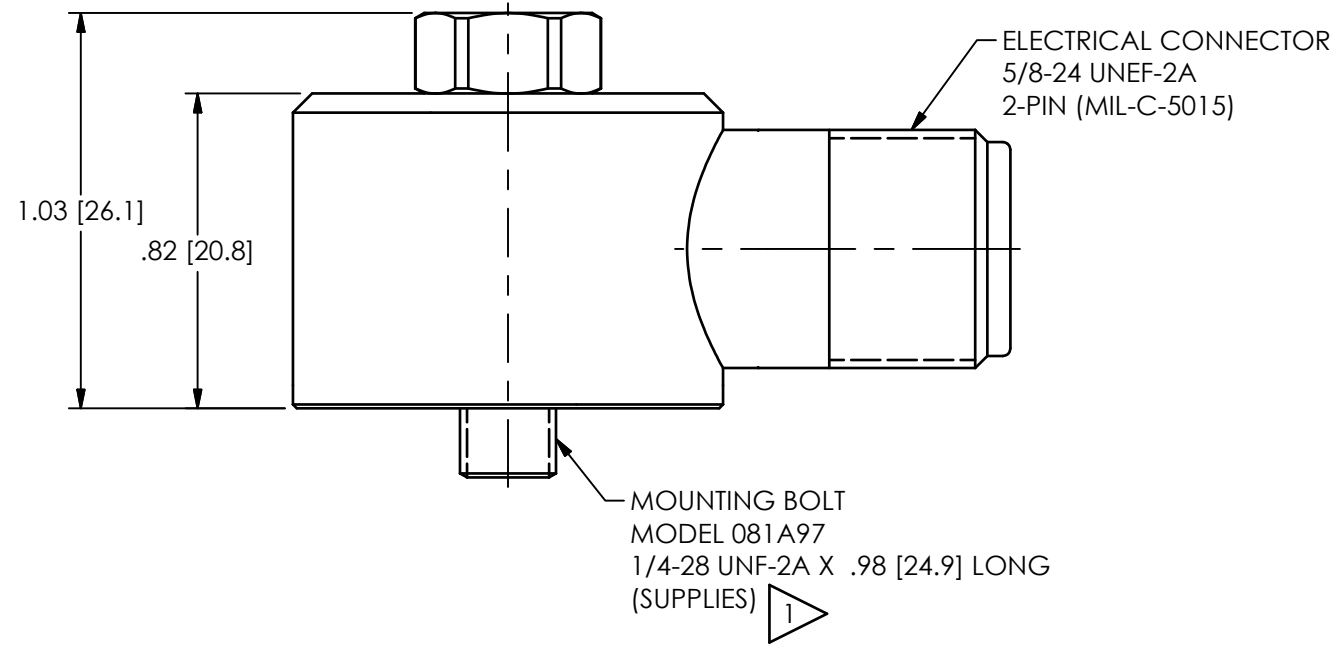
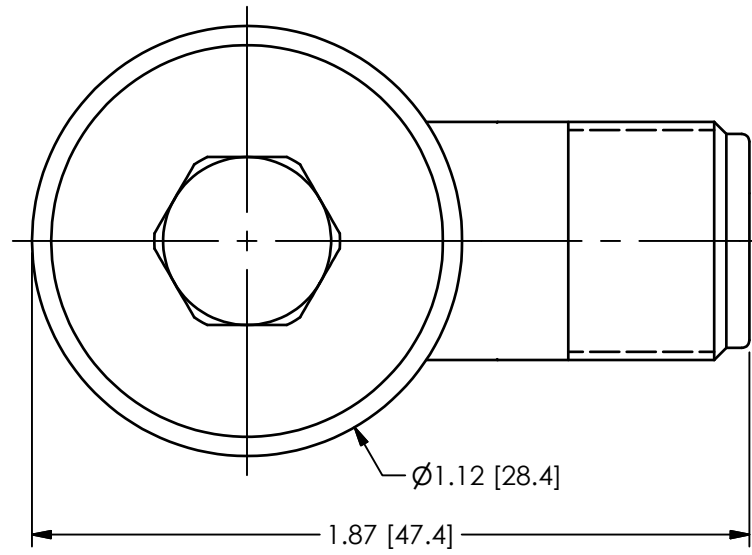

1 FOR METRIC ACCELEROMETER [M635A01] USE MOUNTING BOLT MODEL M081A97, M6 X 1.00-6g X .98 [24.9] LONG.

UNLESS OTHERWISE SPECIFIED TOLERANCES ARE:		DRAWN		CHECKED		ENGINEER		PCB PIEZOTRONICS™	
DIMENSIONS IN INCHES	DIMENSIONS IN MILLIMETERS [IN BRACKETS]	JDM	4/30/14	ECB	4/30/14	BAM	4/30/14	3425 WALDEN AVE. DEPEW, NY 14043 (716) 684-0001 E-MAIL: sales@pcb.com	
DECIMALS XX ±.03 XXX ±.010	DECIMALS X ±0.8 XX ±0.25	TITLE OUTLINE DRAWING MODEL 635A01, M ACCELEROMETER							
ANGLES ± 2 DEGREES	ANGLES ± 2 DEGREES								
FILLETS AND RADII .003 - .005	FILLETS AND RADII 0.07 - 0.13	CODE IDENT. NO. 52681		DWG. NO. 12951		SCALE: 2X		SHEET 1 OF 1	

jmorawski 07:33 5/1/2014