

2

1

PCB Piezotronics Inc. claims proprietary rights in the information disclosed hereon. Neither it nor any reproduction thereof will be disclosed to others without the written consent of PCB Piezotronics Inc.

REVISIONS

REV	DESCRIPTION	DIN
A	REVISED TITLE	45109

62201

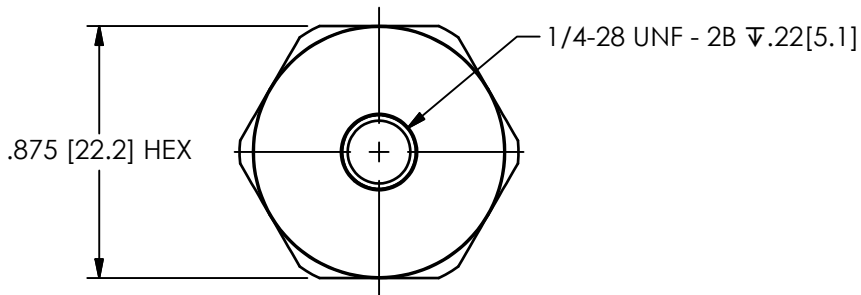
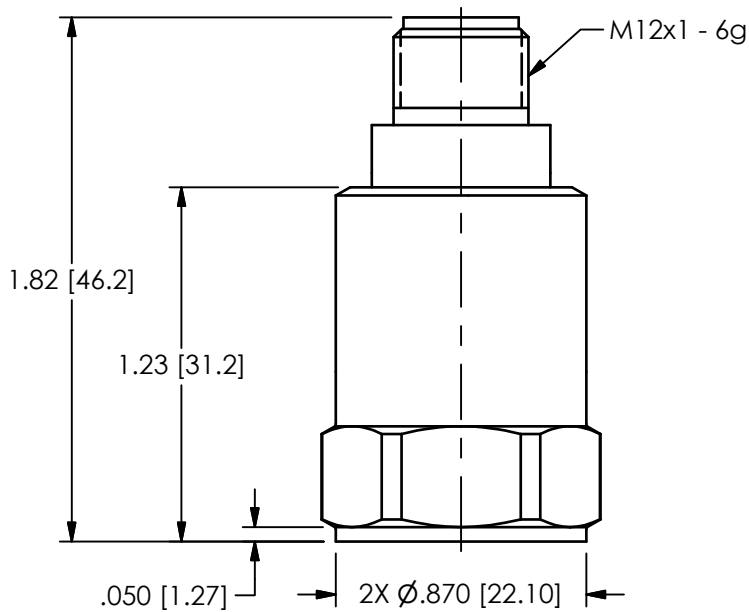
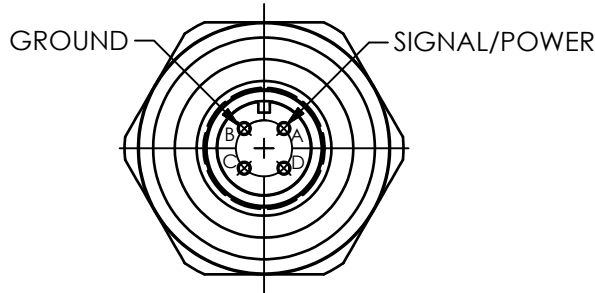

UNLESS OTHERWISE SPECIFIED TOLERANCES ARE:

DRAWN		CHECKED		ENGINEER	
JDM	2/11/16	AF	2/11/16	GCD	2/11/16



3425 WALDEN AVE. DEPEW, NY 14043  
(716) 684-0001 E-MAIL: sales@pcb.com

CODE IDENT. NO. 52681	DWG. NO. 62201
--------------------------	-------------------

SCALE: 1.5X SHEET 1 OF 1

TITLE  
OUTLINE DRAWING  
ACCELEROMETER  
WITH 4-PIN M12 CONNECTOR

DIMENSIONS IN INCHES

DECIMALS XX ±.03  
XXX ±.010  
ANGLES ± 2 DEGREES

DIMENSIONS IN MILLIMETERS [ IN BRACKETS ]

DECIMALS X ± 0.8  
XX ± 0.25  
ANGLES ± 2 DEGREES

FILLETS AND RADII  
.003 - .005

FILLETS AND RADII  
0.07 - 0.13

2

1

1

B

B

A

A