

24186

PCB Piezotronics Inc. claims proprietary rights in the information disclosed hereon. Neither it nor any reproduction thereof will be disclosed to others without written consent of PCB Piezotronics Inc.

APPLICATION		
NEXT ASS'Y	USED ON	VAR

REVISIONS				
REV	DESCRIPTION	ECN	DATE	APP'D
NR	RELEASED TO DRAFTING		10/15/03	dm 10/07

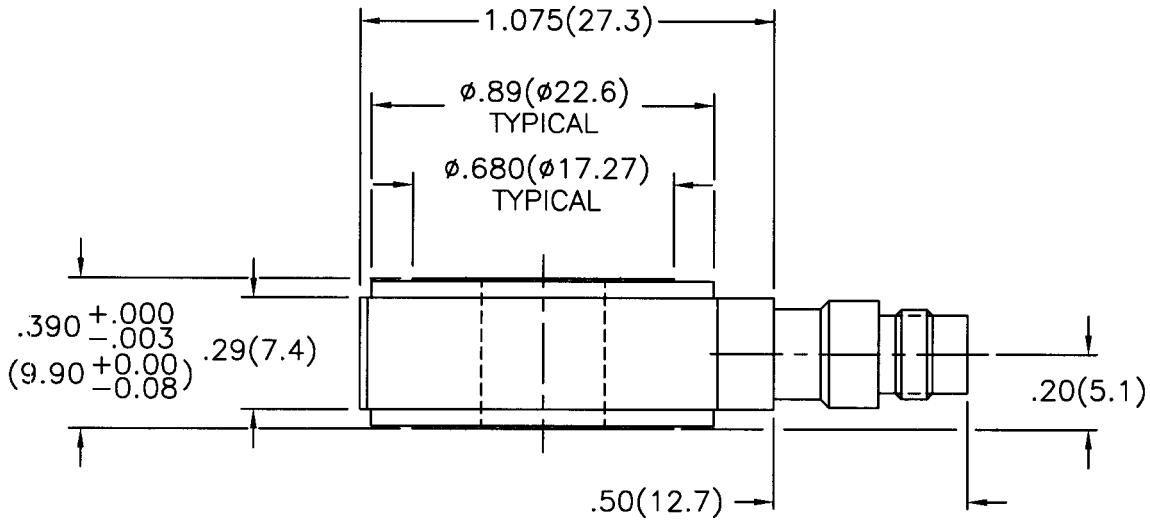
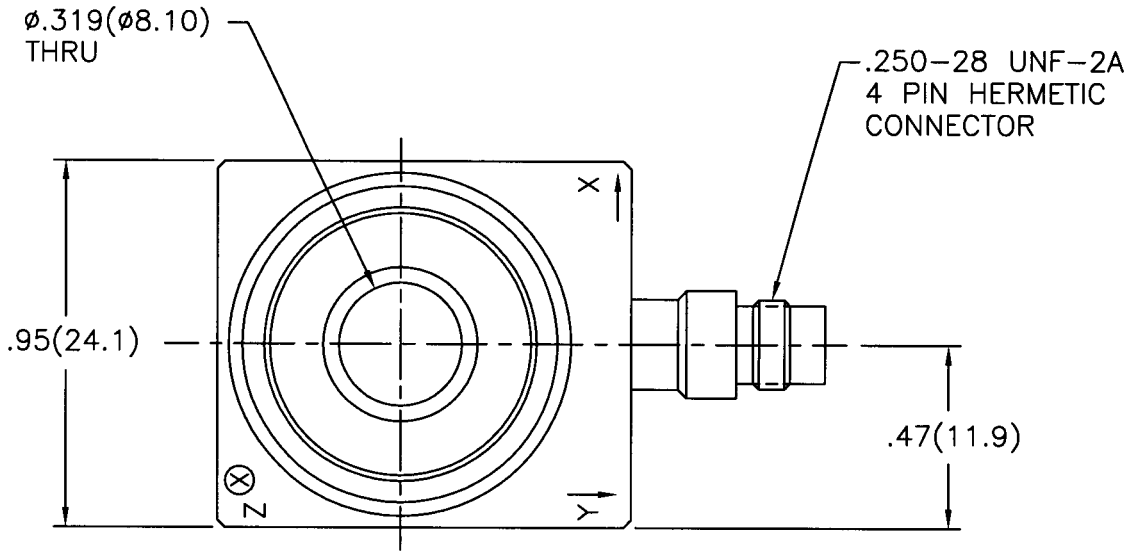

1.) SEE SHEETS 2 AND 3 FOR STANDARD AND METRIC MOUNTING INSTRUCTIONS.

UNLESS SPECIFIED TOLERANCES		DRAWN				MFG		PCB PIEZOTRONICS™	
DIMENSIONS IN INCHES	DIMENSIONS IN MILLIMETERS (IN PARENTHESIS)	AJS	10/15/03		PJL	10/23/03	3425 WALDEN AVE. DEPEW, NY 14043 (716) 684-0001 EMAIL: SALES@PCB.COM		
DECIMALS XX ±.01	DECIMALS XX ±0.3	CHK'D	DM	10/16/03	ENGR				
XXX ±.005	XXX ±0.13	APP'D	DMB	10/27/03	Sales	Jmm			
ANGLES ±2 DEGREES	ANGLES ±2 DEGREES	TITLE	INSTALLATION DRAWING				CODE	DWG. NO.	
FILLETS AND RADII	FILLETS AND RADII	MODEL (M)260M21 ICP				IDENT. NO.	24186		
.003 - .005	(0.07 - 0.13)	TRIAxIAL FORCE SENSOR				52681			
DD011 REV. B 03/13/98						SCALE: 2X		SHEET 1 OF 3	

APPLICATION			REVISIONS				
NEXT ASS'Y	USED ON	VAR	REV	DESCRIPTION	ECN	DATE	APP'D
				-SEE SHEET ONE-			

24186

PCB Piezotronics Inc. claims proprietary rights in the information disclosed hereon. Neither it nor any reproduction thereof will be disclosed to others without written consent of PCB Piezotronics Inc.

MODEL 081A70
STUD
5/16-24 UNF-2A
TYP EACH END
(SUPPLIED)

MODEL 083A10
PILOT BUSHING
(SUPPLIED)

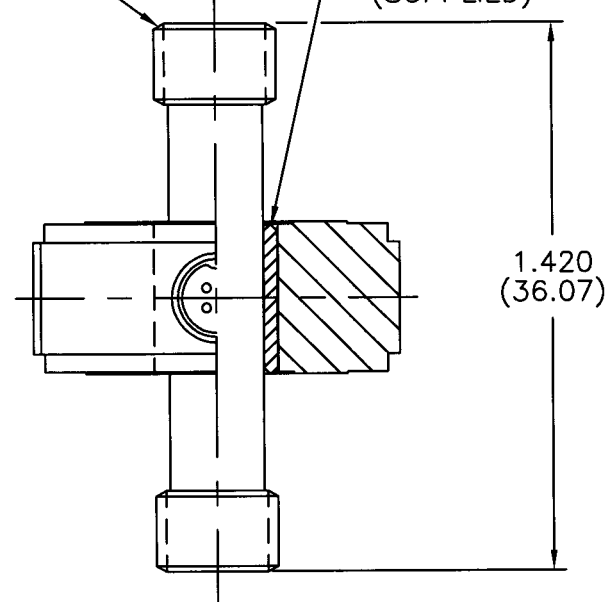

TYP STUD MOUNTING
INSTALLATION

MOUNTING HOLE PREPARATION:

DRILL $\phi .272(\phi 6.91)$ $\triangle 3$
X .655(16.64) ∇
TAP 5/16-24 UNF-2B
X .555(14.10) ∇
PERFECT THREAD

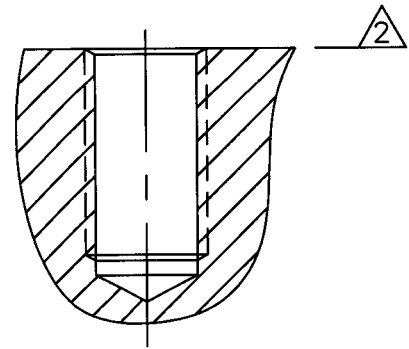

- 4.) SEE MANUAL FOR PRELOAD INSTRUCTIONS.
- $\triangle 3$ DRILL PERPENDICULAR TO MOUNTING SURFACE TO WITHIN $\pm 1^\circ$.
- $\triangle 2$ MOUNTING SURFACE UNDER FORCE RING MUST BE FLAT WITHIN .001(0.03) TIR WITH A 32/ (0.8/) FINISH.

UNLESS SPECIFIED TOLERANCES		DRAWN	ASJ	10/15/03	MFG	Pa	10/26/03	 3425 WALDEN AVE. DEPEW, NY 14043 (716) 684-0001 EMAIL: SALES@PCB.COM
DIMENSIONS IN INCHES	DIMENSIONS IN MILLIMETERS (IN PARENTHESIS)	CHK'D	Dm	10/16/03	ENGR	Z.S	11/22/03	
DECIMALS XX $\pm .01$ XXX $\pm .005$	DECIMALS XX ± 0.3 XXX ± 0.13	APP'D	Dwg	10/27/03	Jales	99m	11/21/03	CODE IDENT. NO. 52681
ANGLES ± 2 DEGREES	ANGLES ± 2 DEGREES	TITLE						DWG. NO. 24186
FILLETS AND RADII .003 - .005	FILLETS AND RADII (0.07 - 0.13)	INSTALLATION DRAWING MODEL 260M21 ICP TRIAxIAL FORCE SENSOR						SCALE: 2X
DD007 REV. B 03/13/98								SHEET 2 OF 3

24186

PCB Piezotronics Inc. claims proprietary rights in the information disclosed hereon. Neither it nor any reproduction thereof will be disclosed to others without written consent of PCB Piezotronics Inc.

APPLICATION

NEXT ASS'Y	USED ON	VAR

REVISIONS

REV	DESCRIPTION	ECN	DATE	APP'D
	-SEE SHEET ONE-			

MODEL M081A70
STUD
M8 X 1.25-6g
TYP EACH END
(SUPPLIED)

MODEL 083A10
PILOT BUSHING
(SUPPLIED)

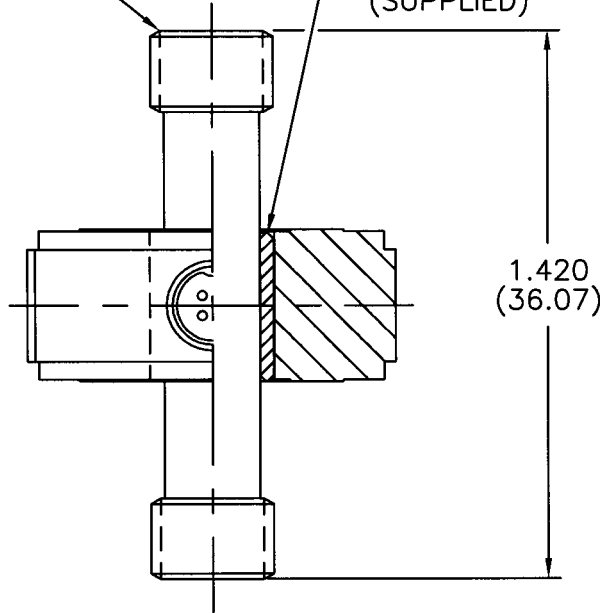

TYP STUD MOUNTING
INSTALLATION

MOUNTING HOLE PREPARATION:

DRILL $\phi .266(\phi 6.80)$ $\triangle 3$
X .655(16.64) ∇
TAP M8 X 1.25-6H
X .555(14.10) ∇
PERFECT THREAD

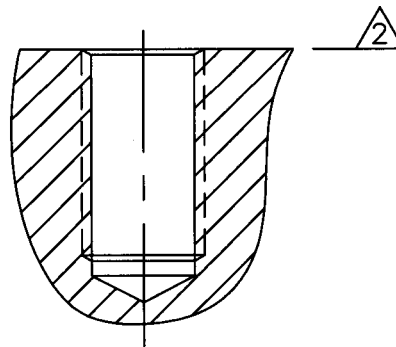

4.) SEE MANUAL FOR PRELOAD INSTRUCTIONS.

$\triangle 3$ DRILL PERPENDICULAR TO MOUNTING SURFACE TO WITHIN $\pm 1^\circ$.

$\triangle 2$ MOUNTING SURFACE UNDER FORCE RING MUST BE FLAT WITHIN .001(0.03) TIR WITH A $32/ (0.8/)$ FINISH.

UNLESS SPECIFIED TOLERANCES

DIMENSIONS IN INCHES	DIMENSIONS IN MILLIMETERS (IN PARENTHESIS)
DECIMALS XX $\pm .01$	DECIMALS XX ± 0.3
XXX $\pm .005$	XXX ± 0.13
ANGLES ± 2 DEGREES	ANGLES ± 2 DEGREES
FILLETS AND RADII .003 - .005	FILLETS AND RADII (0.07 - 0.13)

DRAWN	ASS	10/15/03	MFG	P2	10/20/03
CHK'D	DM	10/16/03	ENGR	KAB	10/22/03
APP'D	DMP	10/27/03	SALS	BHR	10/30/03
TITLE INSTALLATION DRAWING MODEL M260M21 ICP TRIAxIAL FORCE SENSOR					

PCB PIEZOTRONICS	
3425 WALDEN AVE. DEPEW, NY 14043 (716) 684-0001 EMAIL: SALES@PCB.COM	
CODE IDENT. NO. 52681	DWG. NO. 24186
SCALE: 2X	SHEET 3 OF 3