

3873

PCB Piezotronics Inc. claims proprietary rights in the information disclosed hereon. Neither it nor any reproduction thereof will be disclosed to others without written consent of PCB Piezotronics Inc.

APPLICATION		
NEXT ASS'Y	USED ON	VAR

REVISIONS				
REV	DESCRIPTION	ECN	DATE	APP'D

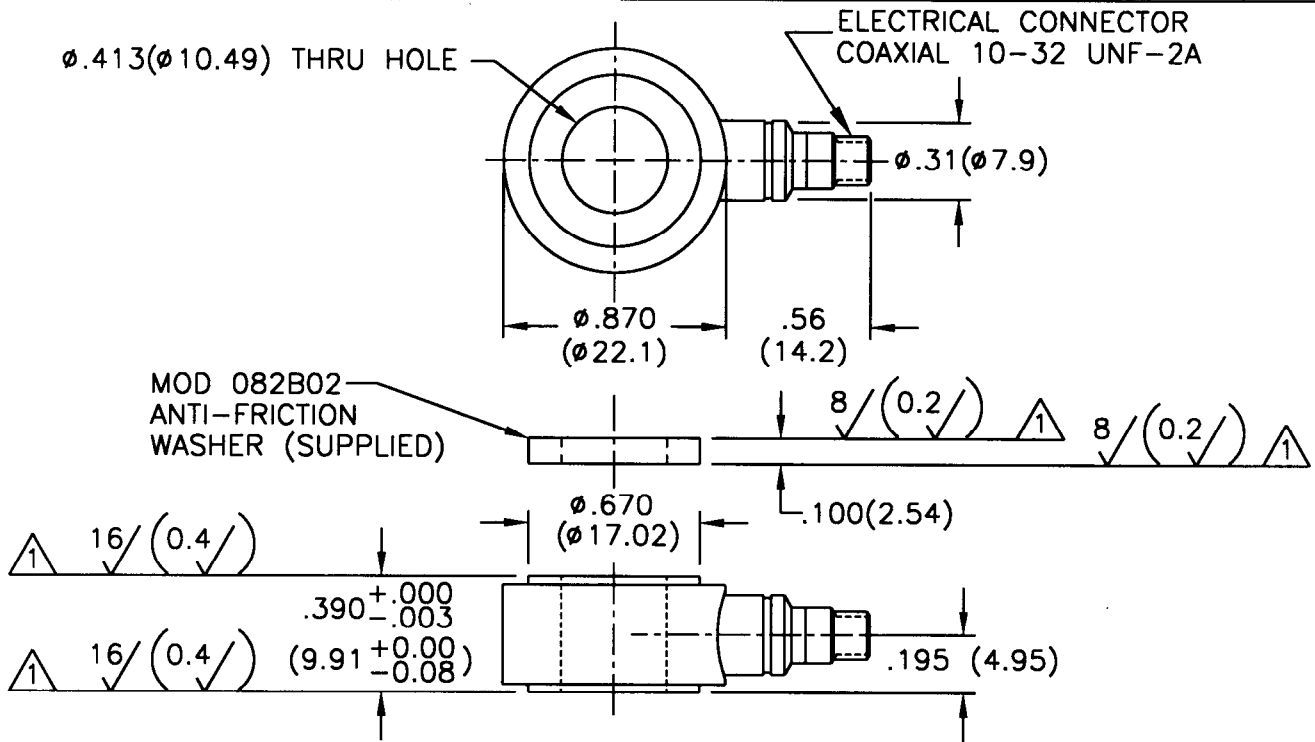

3/8 IN. THD BOLT (NOT SUPPLIED)

ANTI-FRICTION WASHER

MOD 083B02 PILOT BUSHING (SUPPLIED)

MOD 081A12 STUD 5/16-24 UNF-2A TYP EACH END (SUPPLIED)

DRILL & TAP AS REQUIRED FOR 3/8 IN. THREAD BOLT

DRILL  $\phi .272 (\phi 6.91)$   
 x .350 (8.89)  
 TAP 5/16-24 UNF-2B  
 x .250 (6.35)  
 PERF THREAD

4.) SEE MANUAL FOR PRELOAD INSTRUCTIONS.

- ③ DRILL PERPENDICULAR TO MOUNTING SURFACE WITHIN  $\pm 1^\circ$ .
- ② MOUNTING SURFACE UNDER FORCE RING MUST BE FLAT WITHIN .001 (0.03) WITH AT LEAST 125/(3.2) FINISH.
- ① THESE SURFACES FLAT AND PARALLEL TO WITHIN .001 (0.03) TIR.

UNLESS SPECIFIED TOLERANCES		DRAWN		MFG		 3425 WALDEN AVE. DEPEW, NEW YORK 14043 PHONE: (716) 684-0001
DIMENSIONS IN INCHES	DIMENSIONS IN MILLIMETERS (IN PARENTHESIS)	CHK'D	DATE	ENGR	DATE	
DECIMALS XX $\pm .01$ XXX $\pm .005$ ANGLES $\pm 2$ DEGREES	DECIMALS XX $\pm 0.3$ XXX $\pm 0.13$ ANGLES $\pm 2$ DEGREES	im	1/26/96	WSH	2/2/96	DWG. NO.
FILLETS AND RADII .003 - .005	FILLETS AND RADII (0.07 - 0.13)	TITLE				3873
DD011 REV. A 05/26/95		INSTALLATION DRAWING MODEL 202M32 FORCE RING				SCALE: 1.33=1 SHEET 1 OF 1