

36450

PCB Piezotronics Inc. claims proprietary rights in the information disclosed hereon. Neither it nor any reproduction thereof will be disclosed to others without the written consent of PCB Piezotronics Inc.

REVISIONS		
REV	DESCRIPTION	DIN
B	REVISED TITLE	48547

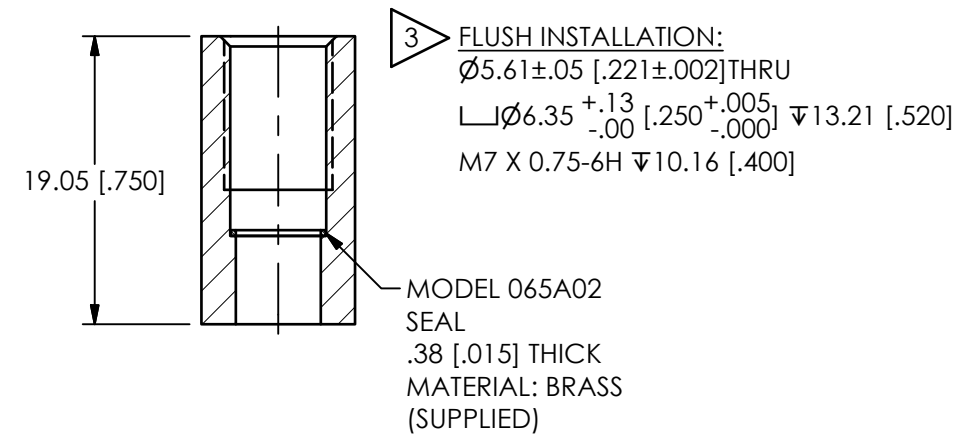
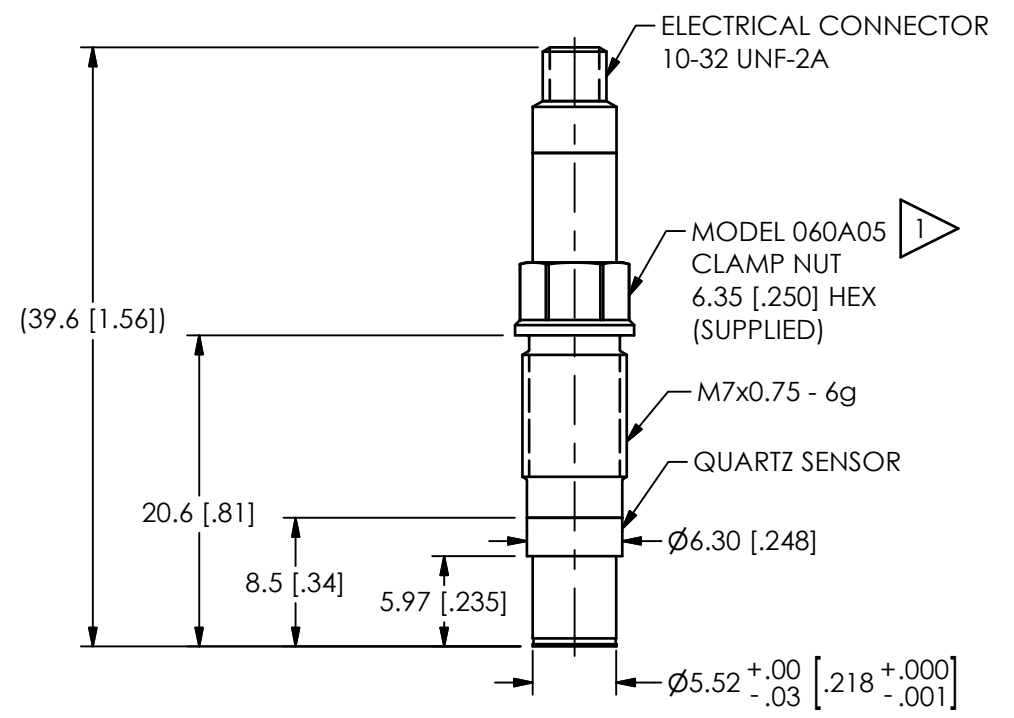

MOUNTING HOLE PREPARATION

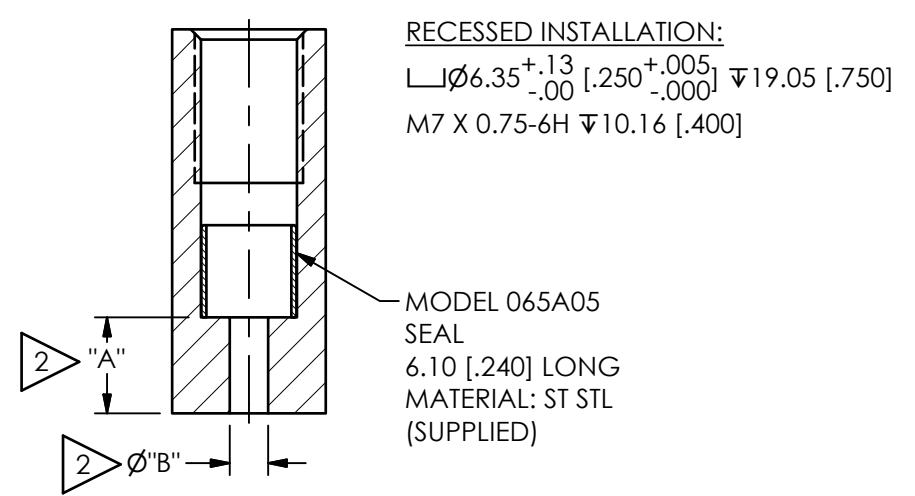

MOUNTING HOLE PREPARATION

- 3 THESE DIMENSIONS FOR 19.1 [.75] THICK WALL, └┐ THICKER WALLS TO THIS DIMENSION
- 2 DIMENSIONS "A" AND Ø"B" TO SUIT USER REQUIREMENTS
- 1 RECOMMENDED TORQUE ON CLAMP NUT 225-395 Ncm [23-35 INCH POUNDS]

UNLESS OTHERWISE SPECIFIED TOLERANCES ARE:		DRAWN		CHECKED		ENGINEER	
DIMENSIONS IN INCHES	DIMENSIONS IN MILLIMETERS [IN BRACKETS]	KRM	9/11/18	KRM	9/11/18	NJL	9/11/18
DECIMALS XX ±.01 XXX ±.005	DECIMALS X ±.03 XX ±.013	TITLE INSTALLATION DRAWING M112 SERIES PRESSURE SENSORS					
ANGLES ± 2 DEGREES	ANGLES ± 2 DEGREES						
FILLETS AND RADII .003 - .005	FILLETS AND RADII 0.07 - 0.13	CODE IDENT. NO. 52681		DWG. NO. 36450		3425 WALDEN AVE. DEPEW, NY 14043 (716) 684-0001 E-MAIL: sales@pcb.com	
		SCALE: 2X		SHEET 1 OF 1			

