

31240

PCB Piezotronics Inc. claims proprietary rights in the information disclosed hereon. Neither it nor any reproduction thereof will be disclosed to others without the written consent of PCB Piezotronics Inc.

REVISIONS			
REV	DESCRIPTION	ECN	APP'D
B	UPDATED DRAWING	23506	ECB 4-06
C	ADDED CHAMFER	28334	

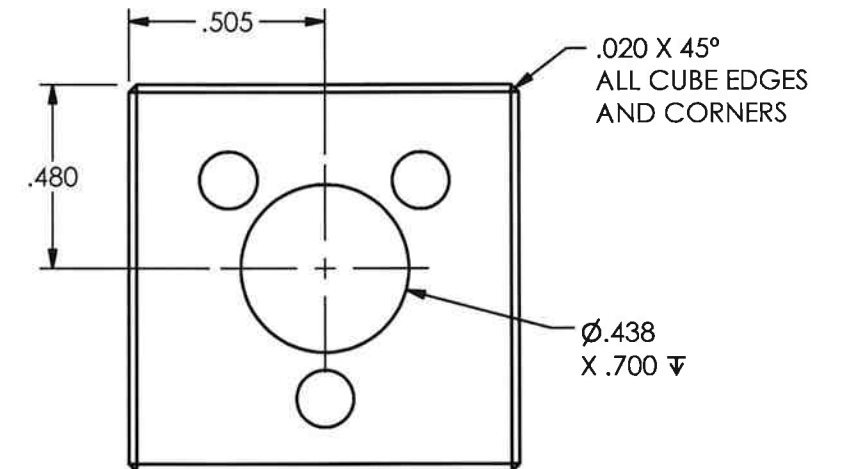
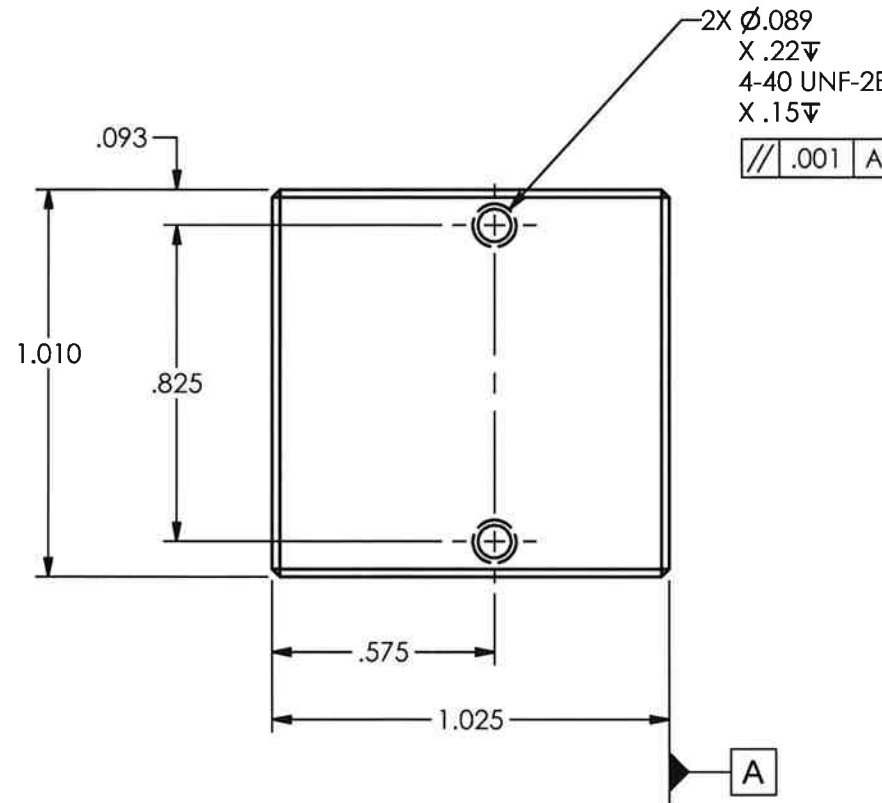
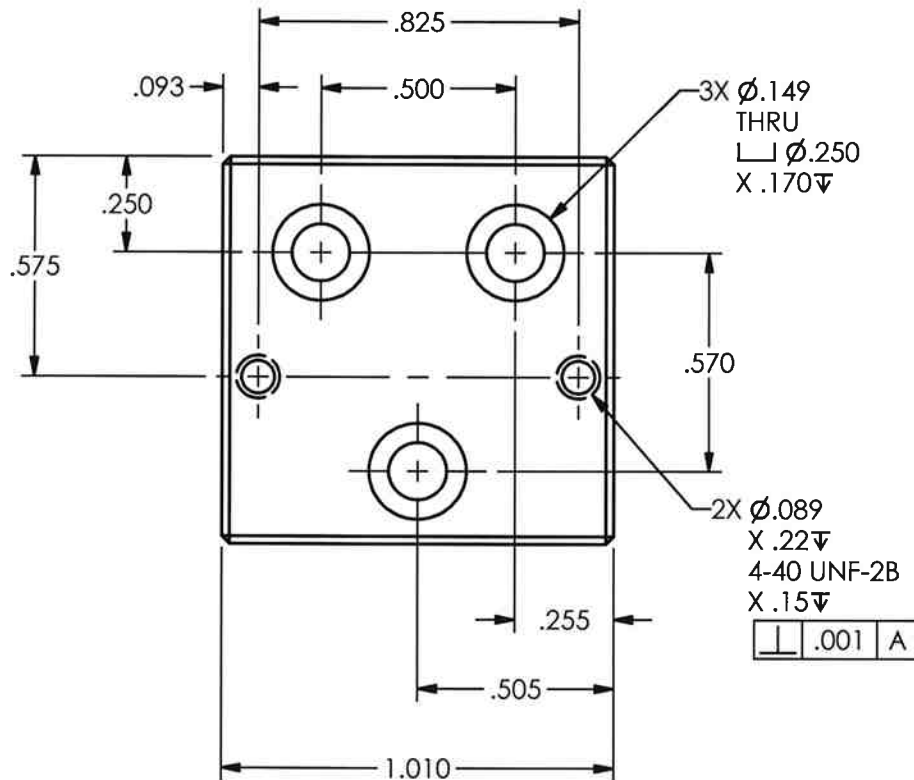
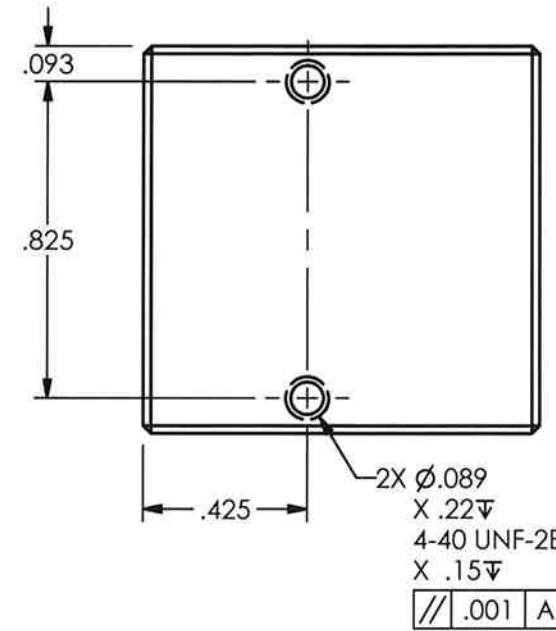
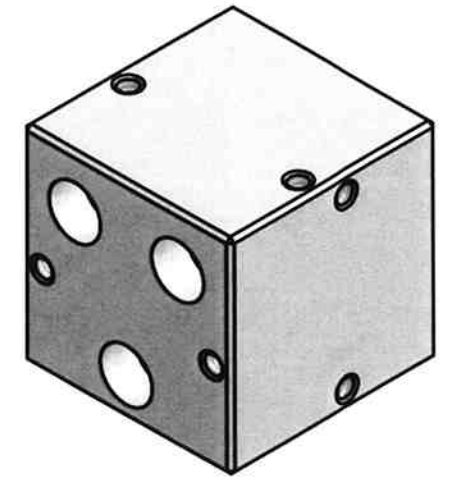

PT NO: 31240-01

1 HARDCOAT PER: MIL-A-8625 TYPE III, CLASS 2, BLACK, EXCEPT FOR THREADED HOLES (.0010 TO .0015 THICK).

UNLESS OTHERWISE SPECIFIED	
DIMENSIONS ARE IN INCHES	
DECIMALS	X ± .05
	XX ± .01
	XXX ± .005
	XXXX ± .0005
ANGLES ± 2 DEGREES	
FILLETS AND RADII .001 - .005 MAX	
HEX DIMENSIONS ARE:	
	< .5 + .000 / - .003
	> .5 + .000 / - .005
INTERNAL THREAD DEPTH MIN.	
REMOVE ALL BURRS	
SHARP = R.000 - R.003	

MATERIAL	7075-T6 AL ALY
HEAT TREAT	
FINISH	1 63 ✓

DRAWN	SMB	3/18/08	MFG	JP	3/4/08
CHK'D			ENGR	BAS	3/4/08
APP'D	EB	3/5/08	SALES		
TITLE					
TRIAx BLOCK					

PCB PIEZOTRONICS	
3425 WALDEN AVE. DEPEW, NY 14043	
(716) 684-0002 E-MAIL: sales@pcb.com	
CODE IDENT. NO. 52681	DWG. NO. 31240
SCALE: 2X	SHEET 1 OF 1